

## Series NL4



AVENTICS™ Series NL4





















# Pressure regulator, Series NL4-RGS

- G 1/2 G 3/4
- Qn = 9500 l/min
- Standard pressure regulator
- Activation Mechanical



Parts	Pressure regulator
Mounting orientation	Any
Working pressure min./max.	See table below
Ambient temperature min./max.	-10 ... 60 °C
Medium temperature min./max.	-10 ... 60 °C
Medium	Compressed air Neutral gases
Regulator type	Diaphragm-type pressure regulator Can be assembled into blocks with relieving air exhaust
Regulator function	
Adjustment range min./max.	See table below
Pressure supply	single
Activation	Mechanical
Weight	See table below

## Technical data

Part No.			Port	Flow	Working pressure min./max.	Adjustment range min./max.
				Qn		
0821302505			G 1/2	9500 l/min	0.5 ... 10 bar	0.1 ... 3 bar
0821302580			G 1/2	9500 l/min	0.5 ... 16 bar	0.2 ... 6 bar
0821302500			G 1/2	9500 l/min	0.5 ... 16 bar	0.5 ... 10 bar
0821302504		—	G 1/2	9500 l/min	0.5 ... 10 bar	0.1 ... 3 bar
0821302506		—	G 1/2	9500 l/min	0.5 ... 10 bar	0.2 ... 6 bar
0821302501		—	G 1/2	9500 l/min	0.5 ... 16 bar	0.5 ... 10 bar
0821302544			G 3/4	9500 l/min	0.5 ... 16 bar	0.1 ... 3 bar
0821302545			G 3/4	9500 l/min	0.5 ... 16 bar	0.2 ... 6 bar
0821302540			G 3/4	9500 l/min	0.5 ... 16 bar	0.5 ... 10 bar
0821302546		—	G 3/4	9500 l/min	0.5 ... 16 bar	0.1 ... 3 bar
0821302547		—	G 3/4	9500 l/min	0.5 ... 16 bar	0.2 ... 6 bar
0821302541		—	G 3/4	9500 l/min	0.5 ... 16 bar	0.5 ... 10 bar

Part No.	Pressure gauge	Weight
0821302505	with pressure gauge	0.935 kg
0821302580	with pressure gauge	0.935 kg
0821302500	with pressure gauge	0.935 kg
0821302504	-	0.85 kg
0821302506	-	0.85 kg
0821302501	-	0.85 kg
0821302544	with pressure gauge	0.935 kg
0821302545	with pressure gauge	0.935 kg
0821302540	with pressure gauge	0.935 kg

Part No.	Pressure gauge	Weight
0821302546	-	0.85 kg
0821302547	-	0.85 kg
0821302541	-	0.85 kg

Nominal flow Qn with secondary pressure p2 = 6 bar at Δp = 1 bar

## Technical information

The pressure dew point must be at least 15 °C under ambient and medium temperature and may not exceed 3 °C .

A change in the flow direction (from air supply on the left to air supply on the right) occurs by rotating installation by 180° about the vertical axis. Please see the operating instructions for further details.

The rear pressure gauge connection on the pressure regulator is closed with a blanking plug, the front connection is open. Depending on the customer application, a second blanking plug may be necessary. Please order separately (see accessories).

Relieving exhaust (≤ 0.3 bar over set pressure).

With rear exhaust (> 3 bar ).

Recommended pre-filtering 5 μm

## Technical information

Material	
Housing	Die cast zinc
Front plate	Acrylonitrile butadiene styrene
Seals	Acrylonitrile butadiene rubber

## Dimensions

### Dimensions

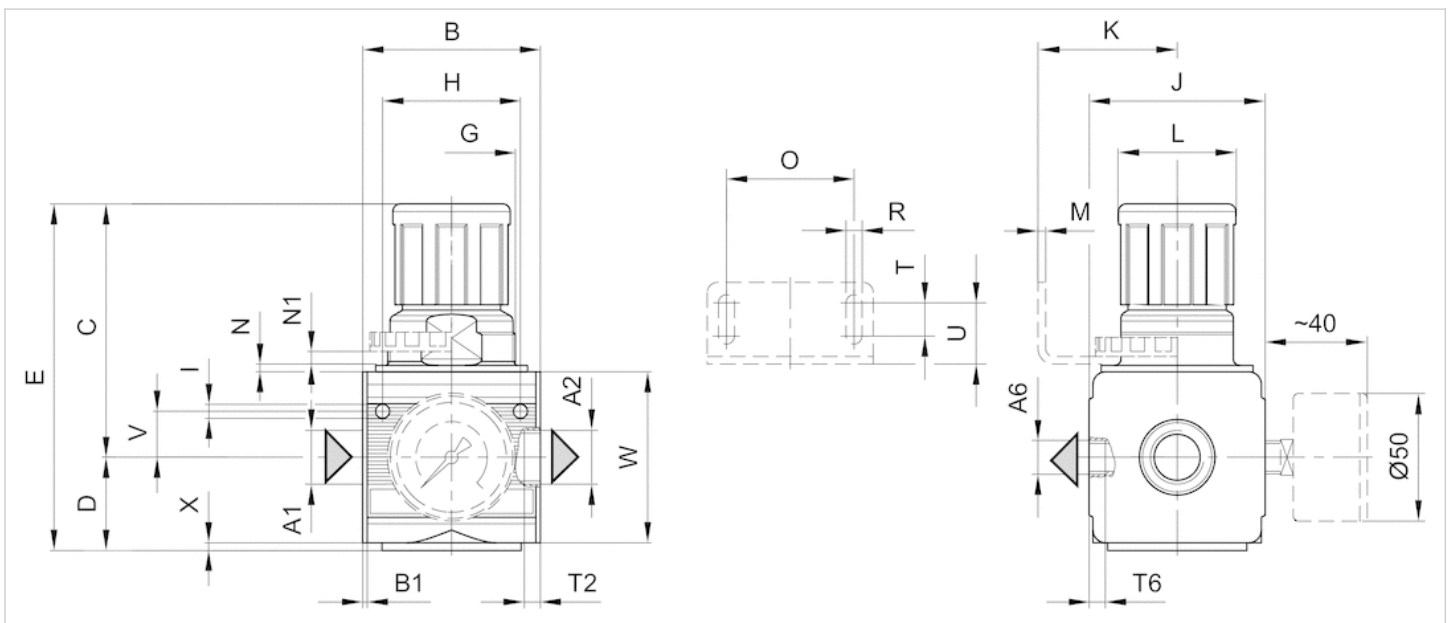

A1 = input