

Series 232P Pressure Switch/Internal Adjustment

Compact, adjustable pressure switch for high pressure hydraulic process applications. Efficient Nega-Rate® Belleville disc spring for set point stability and vibration resistance. Stainless steel wetted materials and hermetically sealed, explosion-proof electricals make this switch ideally suited for hazardous and corrosive media or environments.

Operating Pressure Data

Adjustable Range Number	Adjustable Set Point Range		Deadband (approximate)	Maximum Recommended System Pressure	Proof Pressure
	Increasing	Decreasing			
1	50 to 275	25 to 250	25	5000	7500
2	200 to 1000	75 to 875	125	6500	9750
3	1000 to 3100	700 to 2800	300	6500	9750
4	2800 to 6000	2300 to 5500	500	10000	13500
5	5500 to 8500	4900 to 7900	600	10000	13500
6	7000 to 10000	6000 to 9000	1000	12500	15000

All values given in psig.

Standard Specifications

Electrical

Snap action electrical switch assemblies, Part Numbers 057-0770 & 057-0772 (Form C) and 057-0771 & 057-0773 (Form CC), are listed by Underwriters' Laboratories, Inc., FM Approvals, CSA International and NCC (INMETRO). See the miscellaneous option N for additional listings.

Electrical Connection

1/2 NPT male conduit connection with PVC insulated 18 AWG, 18" long leads

Pressure Connection

1/4 NPT Female

Temperature Range*

Ambient: -40°F to +180°F
(-40°C to +82°C)

Media: -40°F to +250°F
(-40°C to +121°C)

* Temperature limits change with O-Ring selection. See Electrical Assembly specification sheet for Temperature Class Ratings

Adjustment

Internal, slotted adjustment nut with range scale

Shipping Weight

Approximately 20 ounces



Order Miscellaneous Option "D"

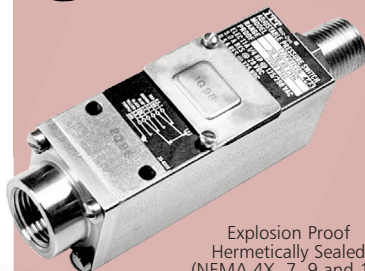

Explosion Proof
Hermetically Sealed
(NEMA 4X, 7, 9 and 13)

Ordering Sequence — Select desired option for each category

OPTIONS

Wetted Material

4 316 stainless steel port and piston, Buna-N O-Ring

Adjustable Range

1 25 psig dec. to 275 psig inc. (1.7 bar dec. to 19.0 bar inc.)
2 75 psig dec. to 1000 psig inc. (5.2 bar dec. to 69.0 bar inc.)
3 700 psig dec. to 3100 psig inc. (48.3 bar dec. to 213.7 bar inc.)
4 2300 psig dec. to 6000 psig inc. (158.6 bar dec. to 413.7 bar inc.)
5 4900 psig dec. to 8500 psig inc. (337.9 bar dec. to 586.1 bar inc.)
6 6000 psig dec. to 10000 psig inc. (413.7 bar dec. to 689.5 bar inc.)

Electrical Form

C 11 amp, 1/4 hp at 125 or 250 VAC; 5 amp resistive, 3 amp inductive at 28 VDC; .5 amp resistive at 125 VDC
CC 11 amp, 1/4 hp at 125 or 250 VAC; 5 amp resistive, 3 amp inductive at 28 VDC; .5 amp resistive at 125 VDC

Enclosure

6 Includes an explosion proof, hermetically-sealed electrical assembly. EX d IIC. Division 1 and 2, Class I, Groups A, B, C, and D; Class II, Groups E, F, and G. NEMA 4X, 7, and 9; IP66. Leads are factory sealed and Pressure Switches are Dual Seal Certified.

Miscellaneous

A Epoxy paint exterior — extra protection for severe environments
B Viton O-Ring
C EPR O-Ring
D SIL approval and marking, per IEC61508 (includes FMEA report)
E 7/16" - 20 SAE Female Port
G 1/2 NPT Female Port
H 316 stainless steel body
I 3/4 NPT conduit box with terminal strip (Groups C & D only, not available with N option)
J Annealed stainless steel port screws for H₂S environments — Consult factory (Not available with range 4,5 & 6)
M Gold electrical contacts for extremely low current applications (1 Amp at 125 VAC; 1 Amp Res, 0.5 Amp Ind. at 28 VDC)
N ATEX and IECEx with CE Mark
R 72" Electrical free leads
U M20 x 1.5 Electrical Conduit Adapter

Special (Consult representative or factory)

- Non-catalog adjustable range and/or set point, deadband and proof pressure

Ordering Procedure

- When factory presetting is desired, stipulate set point, increasing or decreasing
- Insert available option number or letter designation as required

Example

Series
Wetted Material
Adjustable Range
Electrical Form (specify)
Enclosure
Miscellaneous

232P 42 CC 6 _

Envelope Dimensions

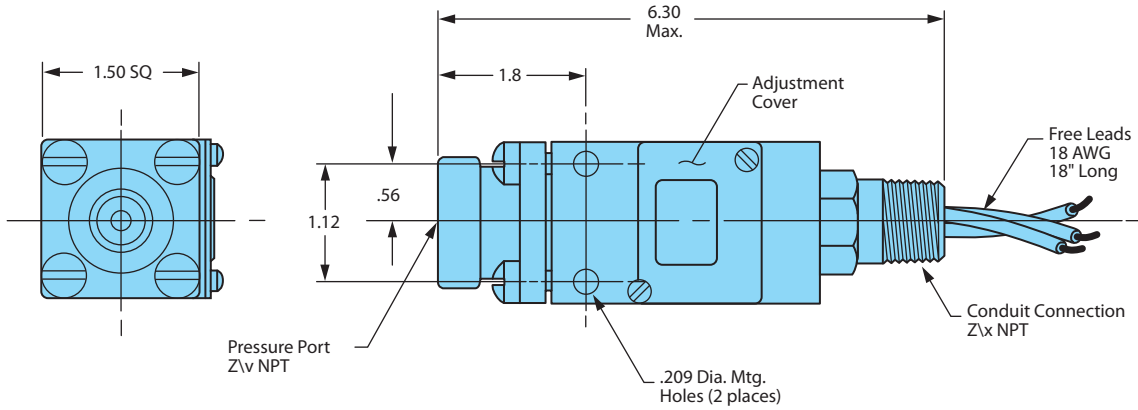

Electrical Form

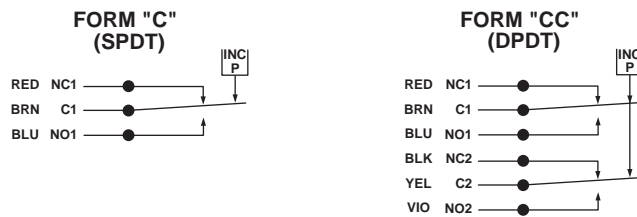

Basic Principles of Design

