

Compact Guide Cylinder *Series MGP*

Ø12, Ø16, Ø20, Ø25, Ø32, Ø40, Ø50, Ø63, Ø80, Ø100

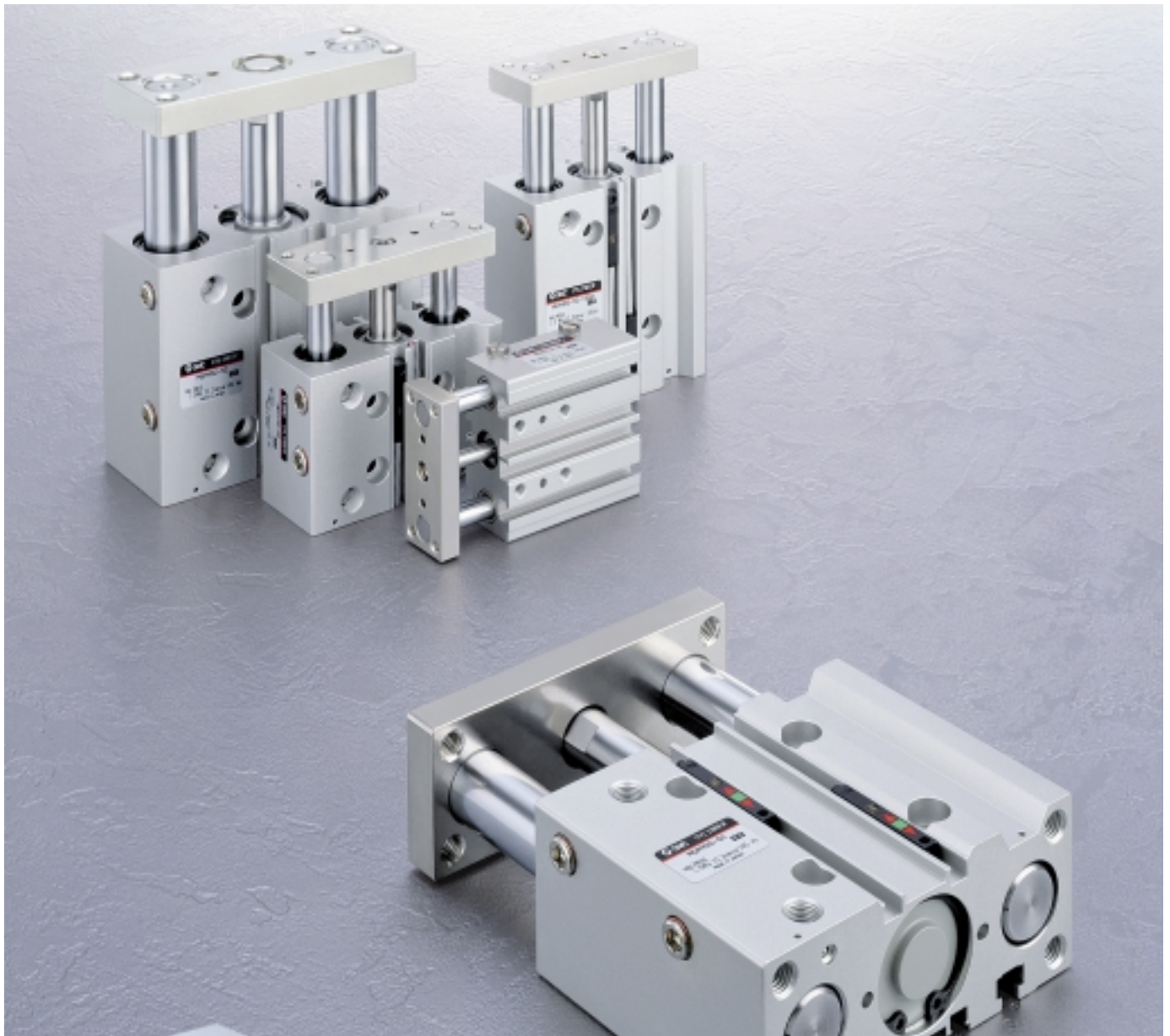

**New end lock type
introduced to Series MGP**

Compact Guide Cylinder Series *MGP*

Ø12, Ø16, Ø20, Ø25, Ø32, Ø40, Ø50, Ø63, Ø80, Ø100

How to Order

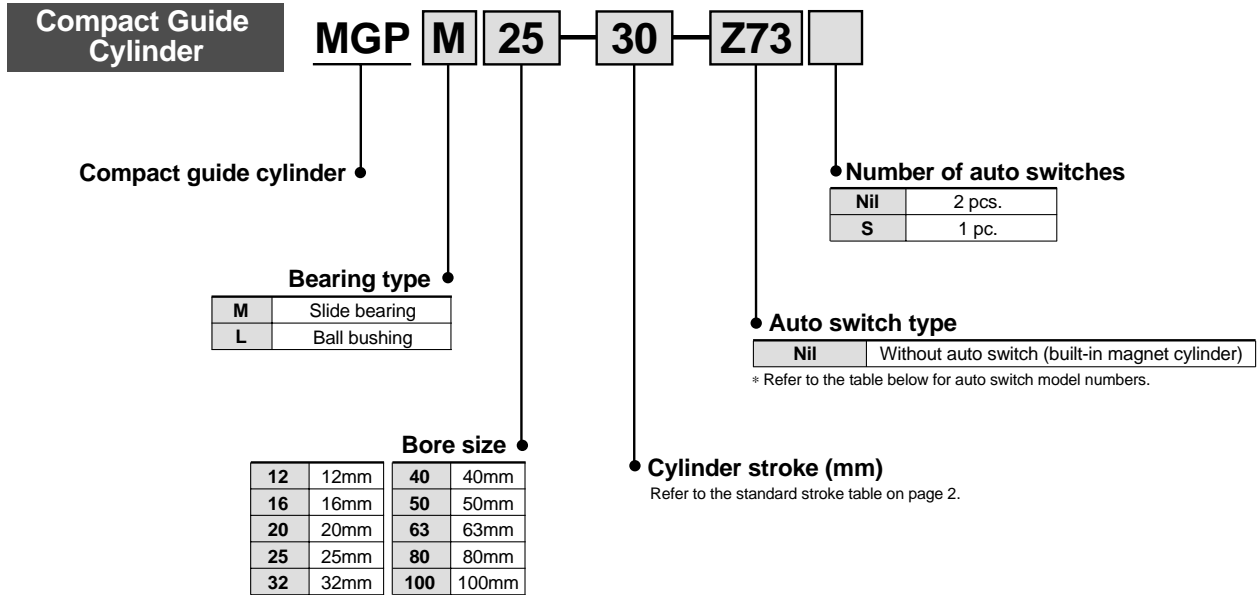

Applicable auto switches

Type	Special function	Electrical entry	Indicator light	Wiring (output)	Load voltage		Auto switch model		Lead wire length (m) ^{Note 1)}			Applicable load		Detailed specifications		
					DC	AC	Electrical entry direction	Perpendicular	In-line	0.5 (Nil)	3 (L)	5 (Z)	IC circuit		Relay, PLC	
Reed switch	—	Grommet	Yes	3 wire	24V	—	5V	—	Z76	●	●	—	IC circuit	Relay, PLC	P. 59	
				2 wire		12V	100V	Z73	●	●	●	—				
Reed switch	—	Grommet	No	2 wire	24V	5V	100V or less	—	Z80	●	●	—	IC circuit	Relay, PLC	P. 59	
				3 wire (NPN)		5V	12V	Y69A	Y59A	●	●	○	IC circuit			
Solid state switch	Diagnostic indication (2 color indicator)	Grommet	Yes	3 wire (PNP)	24V	5V	12V	—	Y7PV	Y7P	●	●	○	IC circuit	Relay, PLC	P. 60
				2 wire					12V	Y69B	Y59B	●	●	○		
Solid state switch	Water resistant (2 color indicator)	Grommet	Yes	3 wire (NPN)	24V	5V	12V	—	Y7NWV	Y7NW	●	●	○	IC circuit	Relay, PLC	P. 61
				3 wire (PNP)					Y7PWV	Y7PW	●	●	○	—		
Solid state switch	Magnetic field resistant (2 color indicator)	Grommet	Yes	2 wire	24V	12V	—	—	Y7BWV	Y7BW	●	●	○	—	Relay, PLC	P. 62
				—					Y7BA	—	●	○	—			
Solid state switch	Magnetic field resistant (2 color indicator)	Grommet	Yes	2 wire	24V	—	—	—	Y5DW ^{Note 3)}	—	●	●	—	IC circuit	Relay, PLC	P. 63
				—					—	—	—	—				

Note 1) Lead wire symbols 0.5m Nil (Example) Y69B
3m L Y69BL
5m Z Y69BZ

Note 2) Solid state auto switches marked with a "O" are produced upon receipt of order.

Note 3) Type D-P5DW cannot be mounted on bore sizes of Ø32 or less.

Series MGP



Specifications

Action	Double acting	
Fluid	Air	
Proof pressure	1.5MPa	
Maximum operating pressure	1.0MPa	
Minimum operating pressure	ø12, ø16	0.12MPa
	ø20 to ø100	0.1MPa
Ambient and fluid temperature	-10 to 60°C (with no freezing)	
Piston speed	ø12 to ø63	50 to 500mm/s
	ø80, ø100	50 to 400mm/s
Cushion	Rubber bumper at both ends	
Lubrication	Non-lube	
Stroke length tolerance	+1.5 0 mm	

Standard Strokes

Bore size (mm)	Standard stroke (mm)
12, 16	10, 20, 30, 40, 50, 75, 100, 125, 150, 175, 200, 250
20, 25	20, 30, 40, 50, 75, 100, 125, 150, 175, 200, 250, 300, 350, 400
32 to 100	25, 50, 75, 100, 125, 150, 175, 200, 250, 300, 350, 400

Manufacture of Intermediate Strokes

Modification method	Spacer installation type Spacers are installed in a standard stroke cylinder. • ø12 to 32 : Available in 1mm stroke increments • ø40 to 100 : Available in 5mm stroke increments		Special body type (-XB10) A special body is manufactured for the specified stroke. • All bore sizes are available in 1mm increments.	
Part number	Refer to standard part numbers and ordering procedure.		Indicate -XB10 at the end of the standard model no. Refer to P.52 for order made specifications.	
Applicable stroke (mm)	ø12, ø16	1 to 249	ø12, ø16	11 to 249
	ø20, ø25, ø32	1 to 399	ø20, ø25	21 to 399
	ø40 to ø100	5 to 395	ø32 to ø100	26 to 399
Example	Part no.: MGPM20-39 A spacer 1mm in width is installed in a MGPM20-40 . C dimension is 77mm.		Part no.: MGPM20-39-XB10 Special body manufactured for 39mm stroke. C dimension is 76mm.	

Note) The minimum stroke for mounting auto switches is 10mm or more for two switches, and 5mm or more for one switch.

Auto switch mounting bracket part no. for D-P5DW

Bore size (mm)	Mounting bracket part no.	Notes
40, 50, 63, 80, 100	BMG1-040	Switch mounting bracket Hexagon socket head cap screw (M2.5 x 0.45 x 8 /) 2 pcs. Hexagon socket head cap screw (M3 x 0.5 x 16 /) 2 pcs. Spring washer (nominal size 3)

Theoretical Output

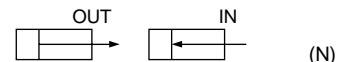

Bore size (mm)	Rod size (mm)	Operating direction	Piston area (mm ²)	Operating pressure (MPa)								
				0.2	0.3	0.4	0.5	0.6	0.7	0.8	0.9	1.0
12	6	OUT	113	23	34	45	57	68	79	90	102	113
		IN	85	17	26	34	43	51	60	68	77	85
16	8	OUT	201	40	60	80	101	121	141	161	181	201
		IN	151	30	45	60	76	91	106	121	136	151
20	10	OUT	314	63	94	126	157	188	220	251	283	314
		IN	236	47	71	94	118	142	165	189	212	236
25	12	OUT	491	98	147	196	246	295	344	393	442	491
		IN	378	76	113	151	189	227	265	302	340	378
32	16	OUT	804	161	241	322	402	482	563	643	724	804
		IN	603	121	181	241	302	362	422	482	543	603
40	16	OUT	1257	251	377	503	629	754	880	1006	1131	1257
		IN	1056	211	317	422	528	634	739	845	950	1056
50	20	OUT	1963	393	589	785	982	1178	1374	1570	1767	1963
		IN	1649	330	495	660	825	990	1154	1319	1484	1649
63	20	OUT	3117	623	935	1247	1559	1870	2182	2494	2805	3117
		IN	2803	561	841	1121	1402	1682	1962	2242	2523	2803
80	25	OUT	5027	1005	1508	2011	2514	3016	3519	4022	4524	5027
		IN	4536	907	1361	1814	2268	2722	3175	3629	4082	4536
100	30	OUT	7854	1571	2356	3142	3927	4712	5498	6283	7069	7854
		IN	7147	1429	2144	2859	3574	4288	5003	5718	6432	7147

Note) Theoretical output (N) = Pressure (MPa) x Piston area (mm²)

Weights

Slide bearing: MGPM12 to 100

(kg)

Bore size (mm)	Model	Standard stroke (mm)															
		10	20	25	30	40	50	75	100	125	150	175	200	250	300	350	400
12	MGPM12	0.24	0.28	—	0.31	0.35	0.39	0.50	0.59	0.70	0.79	0.89	0.98	1.17	—	—	—
16	MGPM16	0.33	0.38	—	0.43	0.48	0.53	0.68	0.80	0.97	1.09	1.22	1.35	1.60	—	—	—
20	MGPM20	—	0.67	—	0.75	0.83	0.91	1.17	1.37	1.57	1.76	1.96	2.16	2.63	3.03	3.42	3.82
25	MGPM25	—	0.95	—	1.05	1.16	1.27	1.65	1.92	2.19	2.47	2.74	3.01	3.67	4.21	4.76	5.30
32	MGPM32	—	—	1.69	—	—	2.07	2.47	2.85	3.24	3.62	4.00	4.38	5.33	6.09	6.86	7.62
40	MGPM40	—	—	1.95	—	—	2.37	2.83	3.25	3.68	4.10	4.53	4.95	5.99	6.85	7.70	8.55
50	MGPM50	—	—	3.36	—	—	4.00	4.73	5.37	6.01	6.65	7.29	7.93	9.54	10.8	12.1	13.4
63	MGPM63	—	—	4.18	—	—	4.94	5.78	6.54	7.29	8.05	8.80	9.56	11.4	12.9	14.4	15.9
80	MGPM80	—	—	6.49	—	—	7.43	8.67	9.61	10.5	11.5	12.4	13.4	15.8	17.7	19.5	21.4
100	MGPM100	—	—	10.5	—	—	11.9	13.6	14.9	16.3	17.6	18.9	20.2	23.6	26.2	28.9	31.5

Ball bushing: MGPL12 to 100

(kg)

Bore size (mm)	Model	Standard stroke (mm)															
		10	20	25	30	40	50	75	100	125	150	175	200	250	300	350	400
12	MGPL12	0.24	0.27	—	0.30	0.35	0.39	0.47	0.56	0.66	0.74	0.83	0.91	1.08	—	—	—
16	MGPL16	0.34	0.39	—	0.43	0.51	0.56	0.67	0.79	0.93	1.04	1.16	1.28	1.50	—	—	—
20	MGPL20	—	0.70	—	0.77	0.89	0.97	1.14	1.31	1.52	1.69	1.87	2.04	2.42	2.77	3.12	3.47
25	MGPL25	—	0.98	—	1.07	1.25	1.34	1.57	1.81	2.08	2.31	2.54	2.77	3.27	3.74	4.20	4.66
32	MGPL32	—	—	1.54	—	—	1.85	2.30	2.62	2.99	3.31	3.62	3.94	4.63	5.26	5.89	6.52
40	MGPL40	—	—	1.79	—	—	2.15	2.64	3.00	3.42	3.78	4.14	4.50	5.28	6.00	6.72	7.44
50	MGPL50	—	—	3.11	—	—	3.66	4.41	4.96	5.60	6.15	6.70	7.25	8.48	9.57	10.7	11.8
63	MGPL63	—	—	3.93	—	—	4.59	5.46	6.12	6.88	7.54	8.21	8.87	10.3	11.7	13.0	14.3
80	MGPL80	—	—	6.25	—	—	7.39	8.69	9.51	10.3	11.1	12.0	12.8	14.7	16.3	18.0	19.6
100	MGPL100	—	—	9.89	—	—	11.6	13.4	14.5	15.7	16.9	18.1	19.3	21.9	24.2	26.6	28.9

Allowable Rotational Torque of Plate

Non-rotating Accuracy of Plate

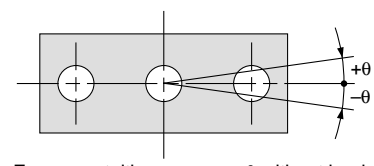
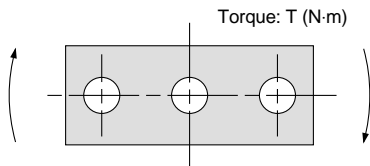

For non-rotating accuracy θ without load, use a value no more than the values in the table as a guide.

T (N-m)

Bore size (mm)	Bearing type	Stroke (mm)															
		10	20	25	30	40	50	75	100	125	150	175	200	250	300	350	400
12	MGPM	0.39	0.32	—	0.27	0.24	0.21	0.43	0.36	0.31	0.27	0.24	0.22	0.19	—	—	—
	MGPL	0.61	0.45	—	0.35	0.58	0.50	0.37	0.29	0.24	0.20	0.18	0.16	0.12	—	—	—
16	MGPM	0.69	0.58	—	0.49	0.43	0.38	0.69	0.58	0.50	0.44	0.40	0.36	0.30	—	—	—
	MGPL	0.99	0.74	—	0.59	0.99	0.86	0.65	0.52	0.43	0.37	0.32	0.28	0.23	—	—	—
20	MGPM	—	1.05	—	0.93	0.83	0.75	1.88	1.63	1.44	1.28	1.16	1.06	0.90	0.78	0.69	0.62
	MGPL	—	1.26	—	1.03	2.17	1.94	1.52	1.25	1.34	1.17	1.03	0.93	0.76	0.65	0.56	0.49
25	MGPM	—	1.76	—	1.55	1.38	1.25	2.96	2.57	2.26	2.02	1.83	1.67	1.42	1.24	1.09	0.98
	MGPL	—	2.11	—	1.75	3.37	3.02	2.38	1.97	2.05	1.78	1.58	1.41	1.16	0.98	0.85	0.74
32	MGPM	—	—	6.35	—	—	5.13	5.69	4.97	4.42	3.98	3.61	3.31	2.84	2.48	2.20	1.98
	MGPL	—	—	5.95	—	—	4.89	5.11	4.51	6.34	5.79	5.33	4.93	4.29	3.78	3.38	3.04
40	MGPM	—	—	7.00	—	—	5.66	6.27	5.48	4.87	4.38	3.98	3.65	3.13	2.74	2.43	2.19
	MGPL	—	—	6.55	—	—	5.39	5.62	4.96	6.98	6.38	5.87	5.43	4.72	4.16	3.71	3.35
50	MGPM	—	—	13.0	—	—	10.8	12.0	10.6	9.50	8.60	7.86	7.24	6.24	5.49	4.90	4.43
	MGPL	—	—	9.17	—	—	7.62	9.83	8.74	11.6	10.7	9.83	9.12	7.95	7.02	6.26	5.63
63	MGPM	—	—	14.7	—	—	12.1	13.5	11.9	10.7	9.69	8.86	8.16	7.04	6.19	5.52	4.99
	MGPL	—	—	10.2	—	—	8.48	11.0	9.74	13.0	11.9	11.0	10.2	8.84	7.80	6.94	6.24
80	MGPM	—	—	21.9	—	—	18.6	22.9	20.5	18.6	17.0	15.6	14.5	12.6	11.2	10.0	9.11
	MGPL	—	—	15.1	—	—	23.3	22.7	20.6	18.9	17.3	16.0	14.8	12.9	11.3	10.0	8.94
100	MGPM	—	—	38.8	—	—	33.5	37.5	33.8	30.9	28.4	26.2	24.4	21.4	19.1	17.2	15.7
	MGPL	—	—	27.1	—	—	30.6	37.9	34.6	31.8	29.3	27.2	25.3	22.1	19.5	17.3	15.5

Bore size (mm)	Non-rotating accuracy θ	
	MGPM	MGPL
12		
16	$\pm 0.08^\circ$	$\pm 0.10^\circ$
20		
25	$\pm 0.07^\circ$	$\pm 0.09^\circ$
32		
40	$\pm 0.06^\circ$	$\pm 0.08^\circ$
50		
63	$\pm 0.05^\circ$	$\pm 0.06^\circ$
80		
100	$\pm 0.04^\circ$	$\pm 0.05^\circ$

Series MGP Model Selection

Selecting Conditions

Mounting orientation	Vertical		Horizontal	
Maximum speed (mm/s)	200	400	200	400
Graph (Slide bearing)	1, 2	3, 4	13, 14	15, 16
Graph (Ball bushing)	5 to 8	9 to 12	17, 18	19, 20

Selection Example 1 (Vertical Mounting)

Selecting conditions
 Mounting: Vertical
 Bearing type: Ball bushing
 Stroke: 30mm
 Maximum speed: 200mm/s
 Load weight: 3kg
 Eccentric distance: 90mm

Find the point of intersection for the load weight of 3kg and the eccentric distance of 90mm on graph **5**, based on vertical mounting, ball bushing, 30mm stroke, and the speed of 200mm/s.
 →MGPL25-30 is selected.

Selection Example 2 (Horizontal Mounting)

Selecting conditions
 Mounting: Horizontal
 Bearing type: Slide bearing
 Distance between plate and load center of gravity: 50mm
 Maximum speed: 200mm/s
 Load weight: 2kg
 Stroke: 30mm

Find the point of intersection for the load weight of 2kg and stroke of 30mm on graph **13**, based on horizontal mounting, slide bearing, the distance of 50mm between the plate and load center of gravity, and the speed of 200mm/s.
 →MGPM20-30 is selected.

5 Less than 40mm stroke V = 200mm/s

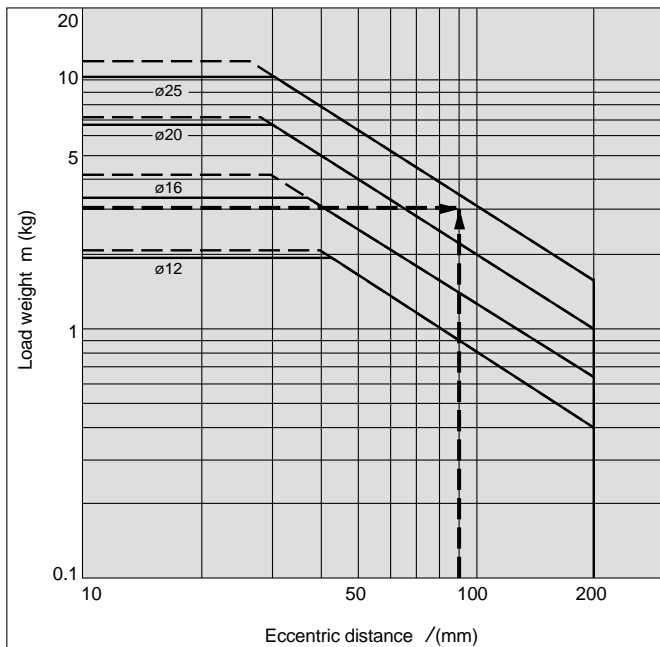

13 $l = 50\text{mm}$ V = 200mm/s

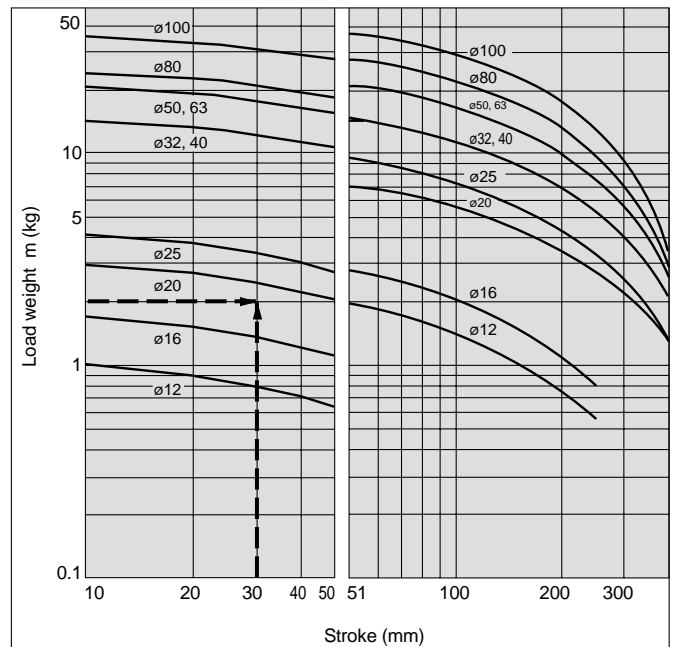

Vertical Mounting **Slide Bearing**

— Operating pressure: 0.4MPa
 - - - - - Operating pressure: 0.5MPa or more

MGPM12 to 100

1 50mm stroke or less V = 200mm/s

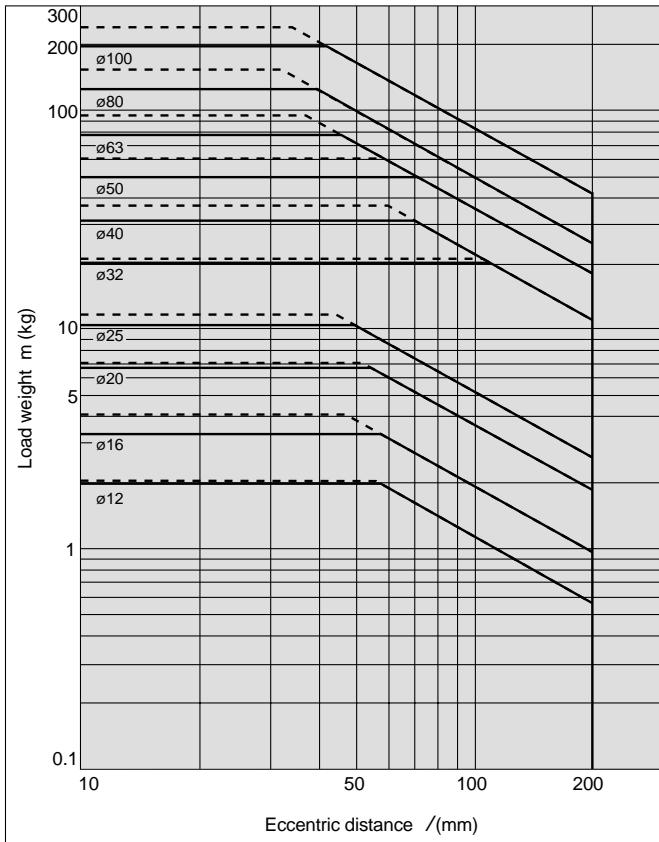

2 Over 50mm stroke V = 200mm/s

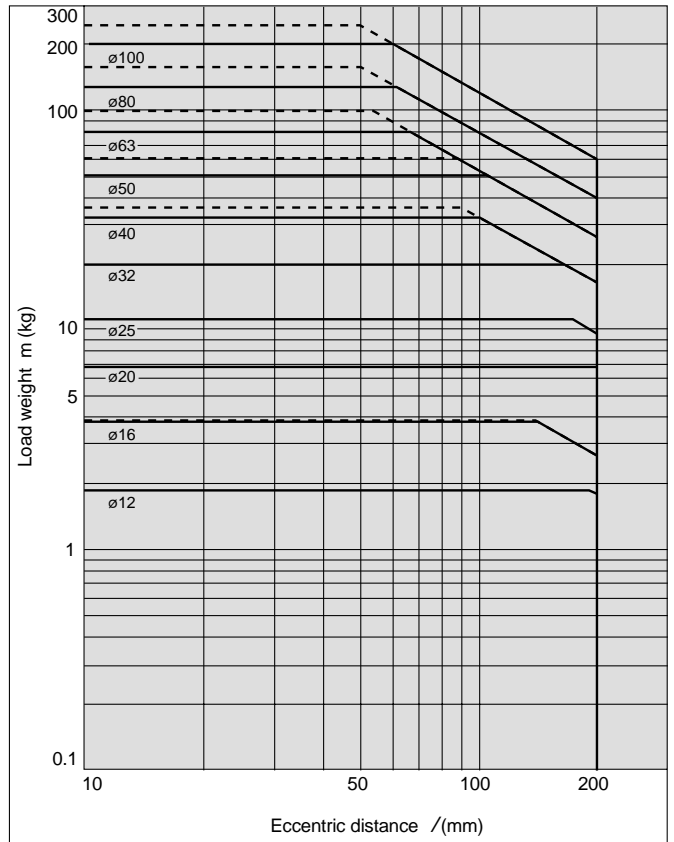

3 50mm stroke or less V = 400mm/s

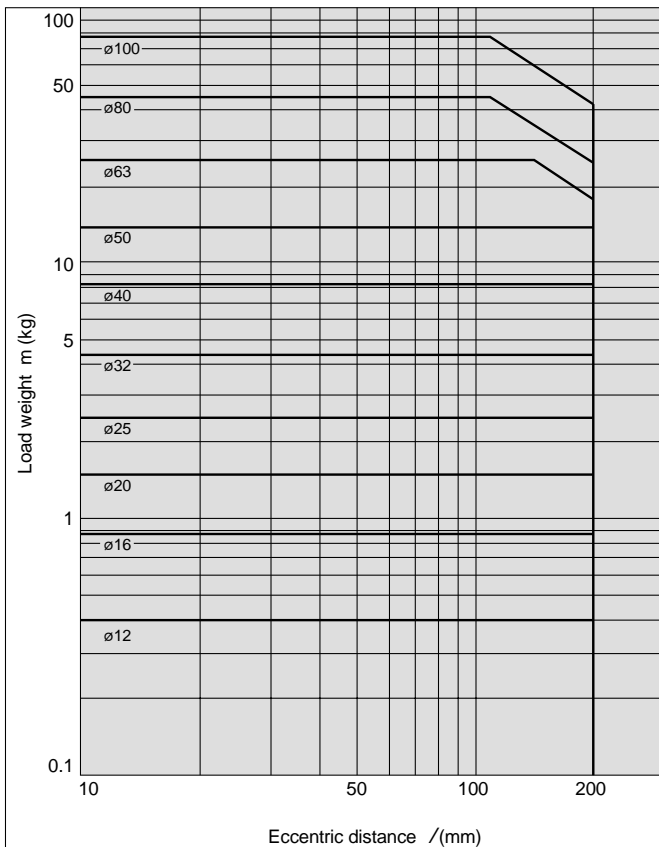

4 Over 50mm stroke V = 400mm/s

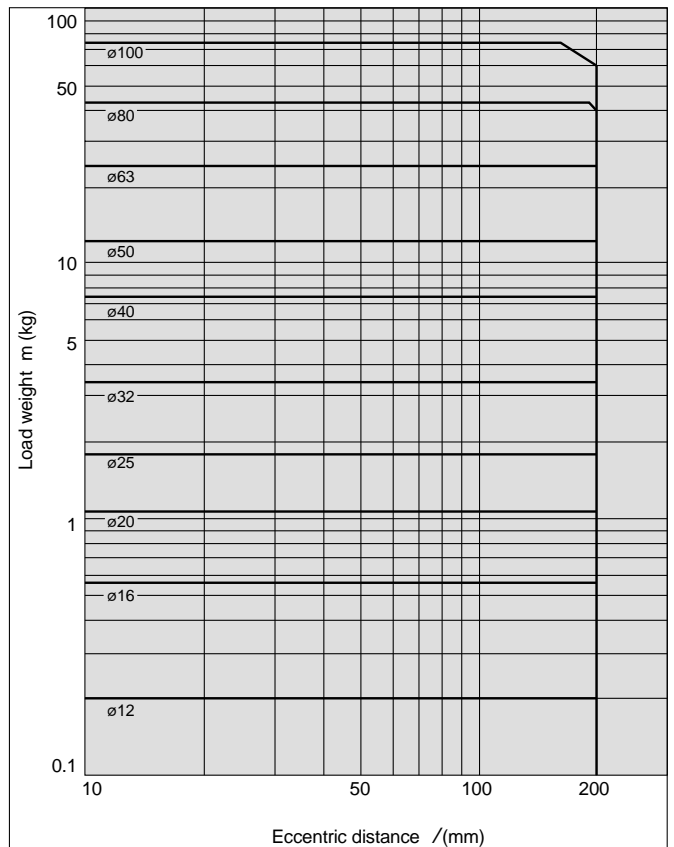

Standard Type
MGP

With Air Cushion
MGP

With End Lock
MGP

Heavy Duty
Guide Rod Type
MGPS

Order Made
Specifications

Auto Switches

Precautions

Series MGP

Vertical Mounting **Ball Bushing**

— Operating pressure: 0.4MPa
 - - - - - Operating pressure: 0.5MPa or more

MGPL12 to 25

5 30mm stroke or less V = 200mm/s

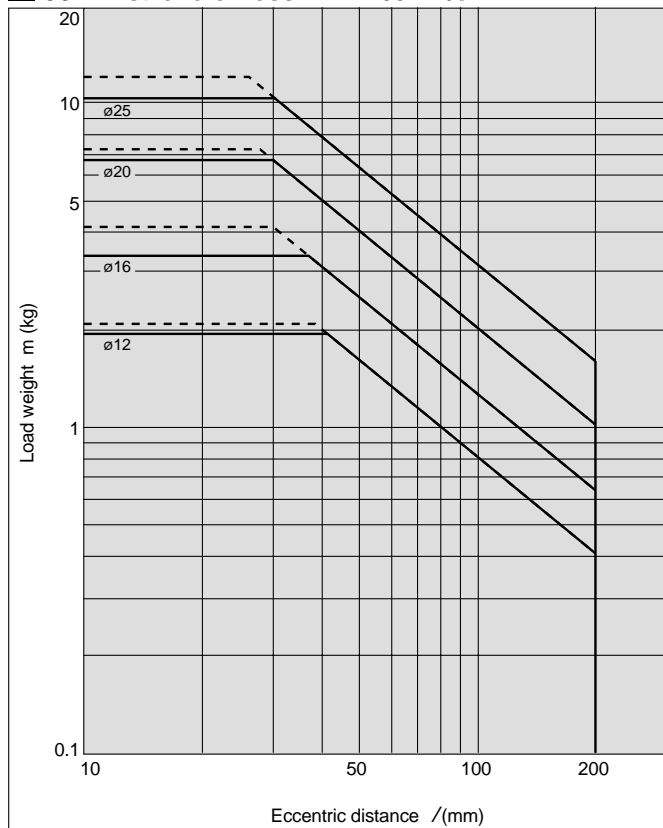

6 Over 30mm stroke V = 200mm/s

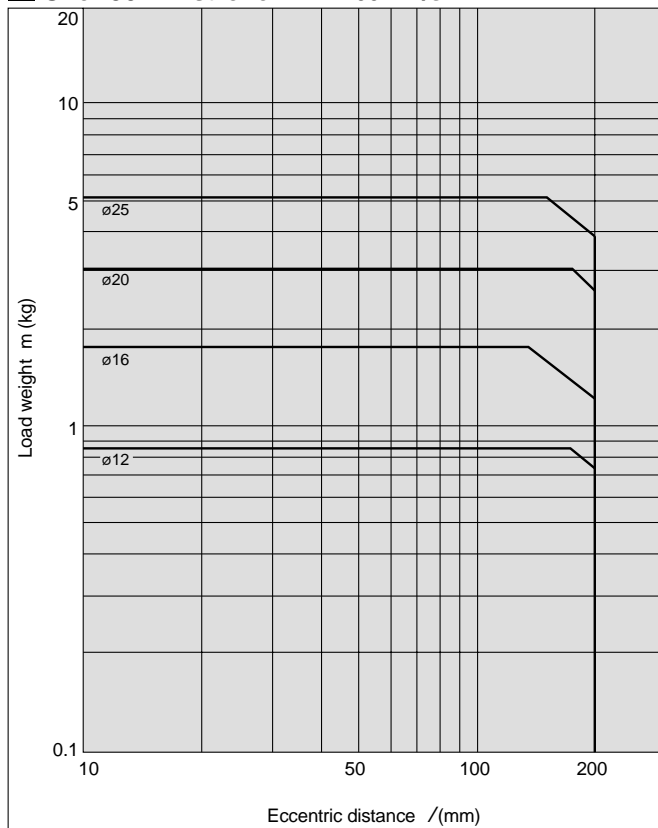

MGPL32 to 100

7 50mm stroke or less V = 200mm/s

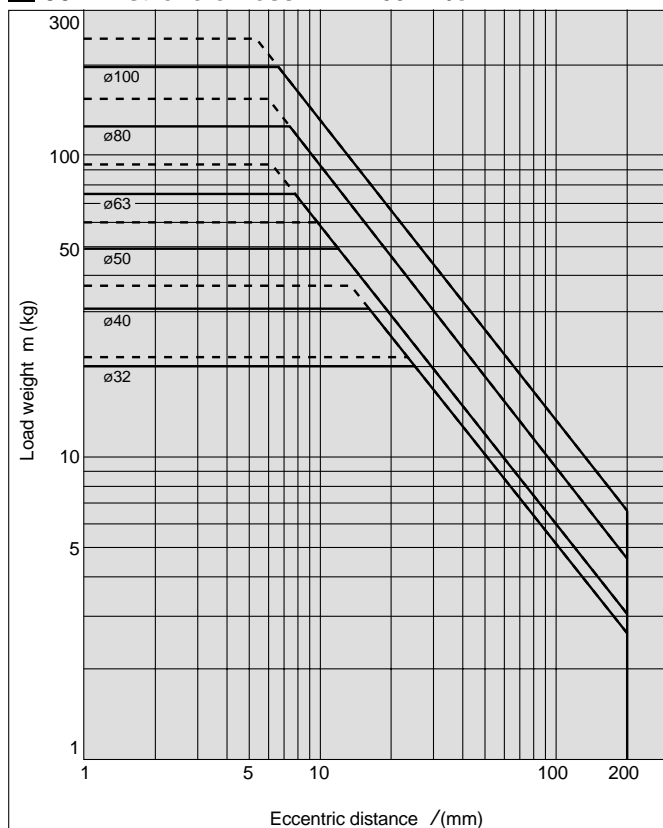

8 Over 50mm stroke V = 200mm/s

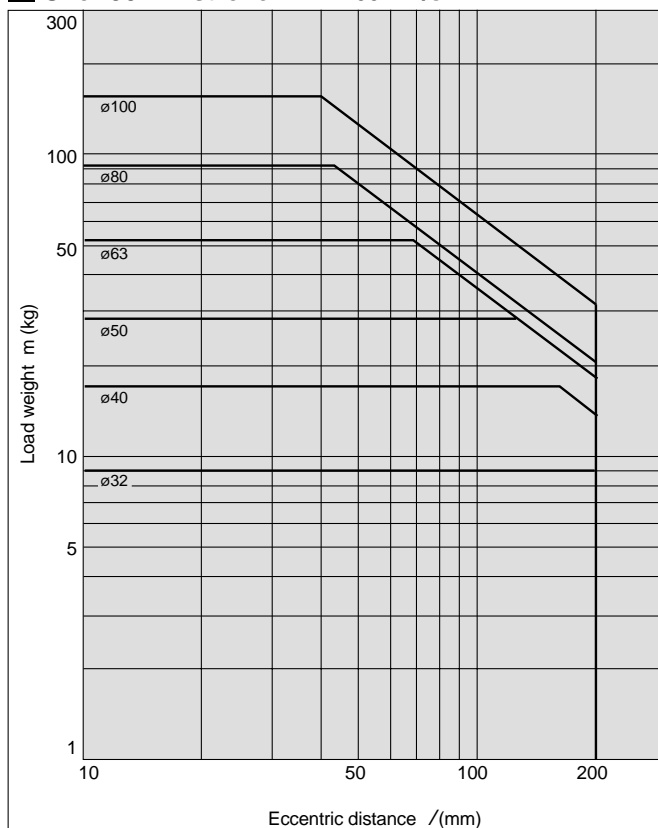

Vertical Mounting **Ball Bushing**

Operating pressure: 0.4MPa

MGPL12 to 25

9 30mm stroke or less V = 400mm/s

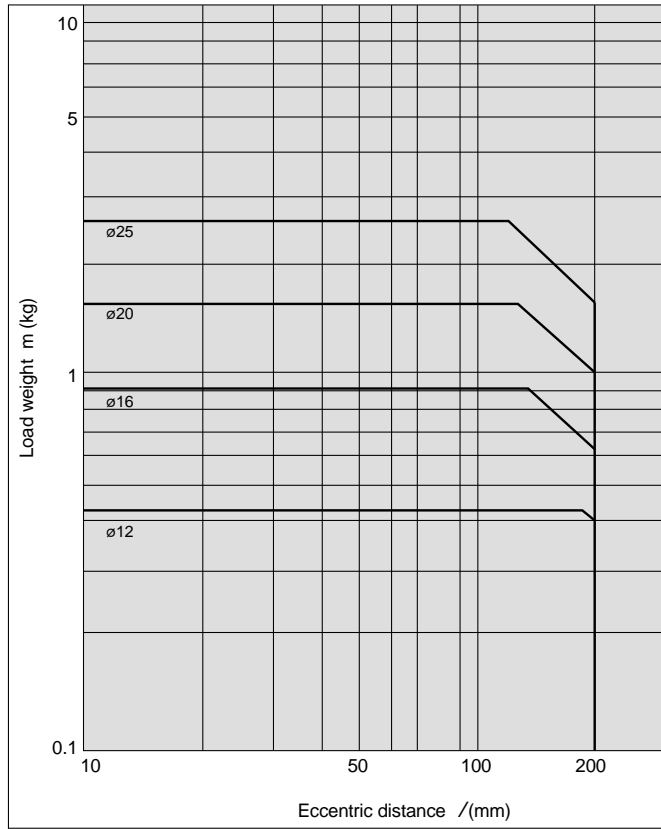

10 Over 30mm stroke V = 400mm/s

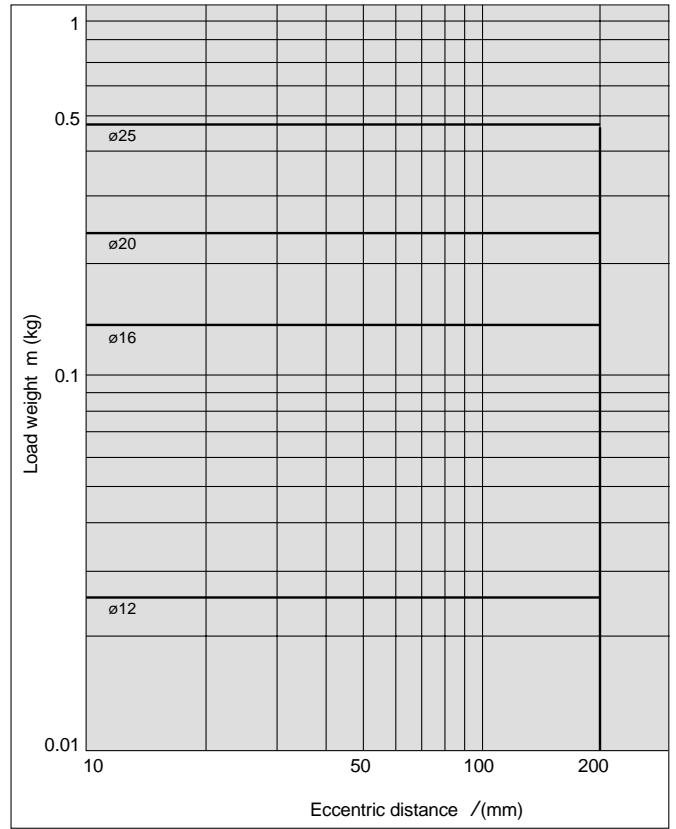

MGPL32 to 100

11 50mm stroke or less V = 400mm/s

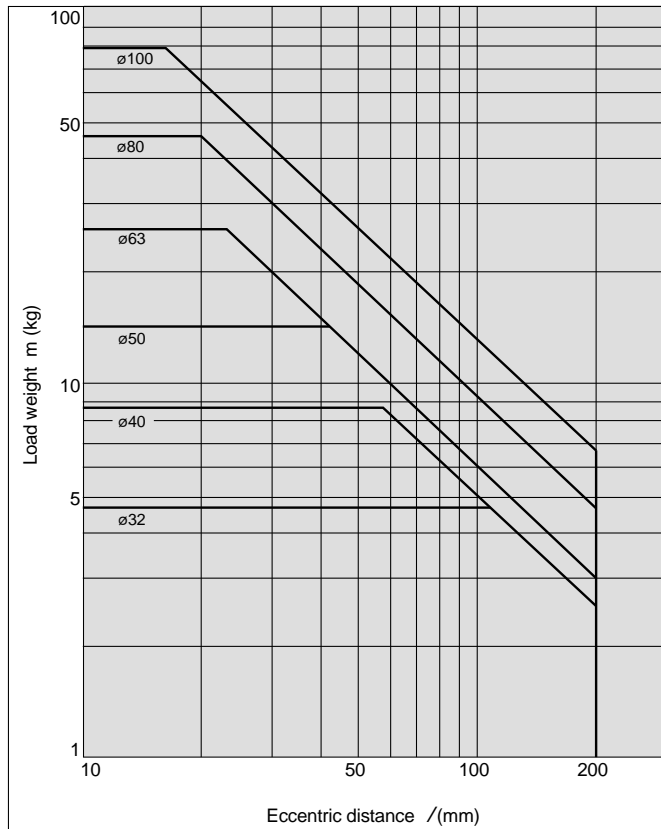

12 Over 50mm stroke V = 400mm/s

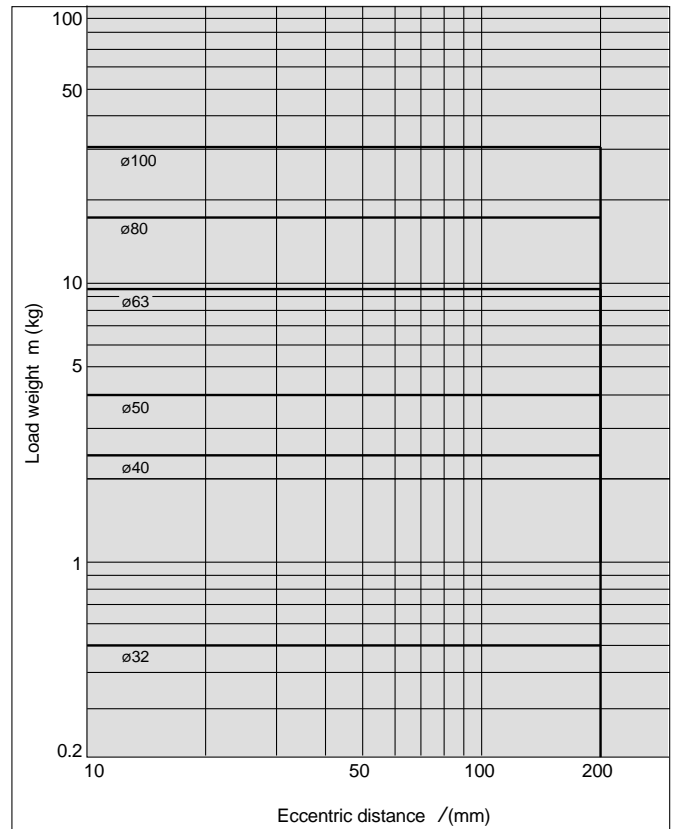

Standard Type
MGP

With Air Cushion
MGP

With End Lock
MGP

Heavy Duty
Guide Rod Type
MGPS

Order Made
Specifications

Auto Switches

Precautions

Series MGP

Horizontal Mounting **Slide Bearing**

MGPM12 to 100

13 $\ell = 50\text{mm}$ $V = 200\text{mm/s}$

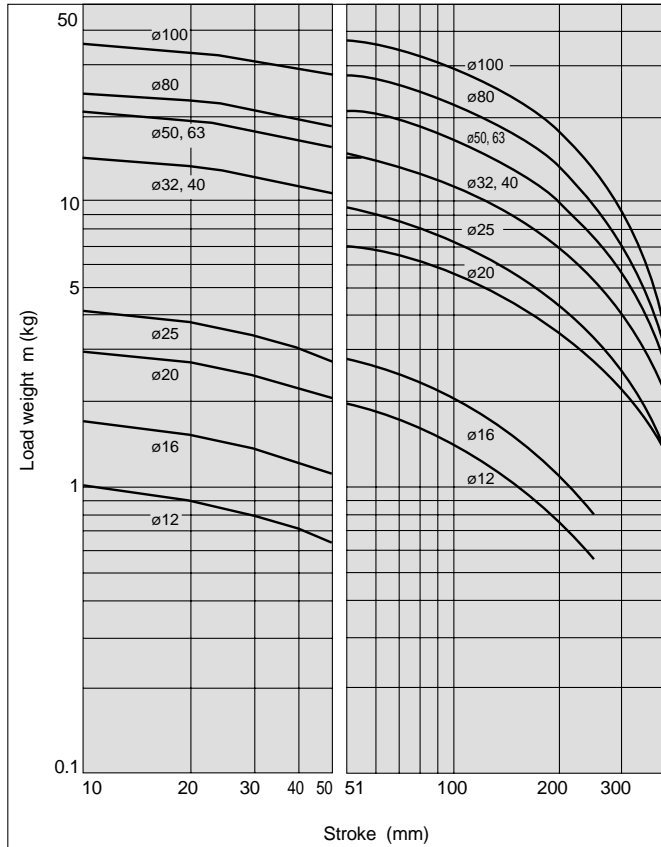

14 $\ell = 100\text{mm}$ $V = 200\text{mm/s}$

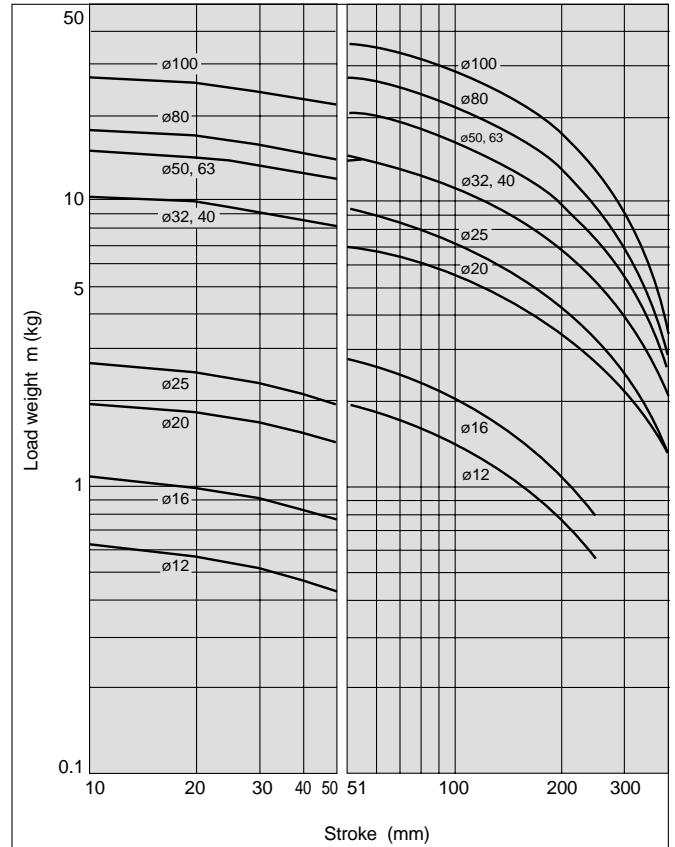

15 $\ell = 50\text{mm}$ $V = 400\text{mm/s}$

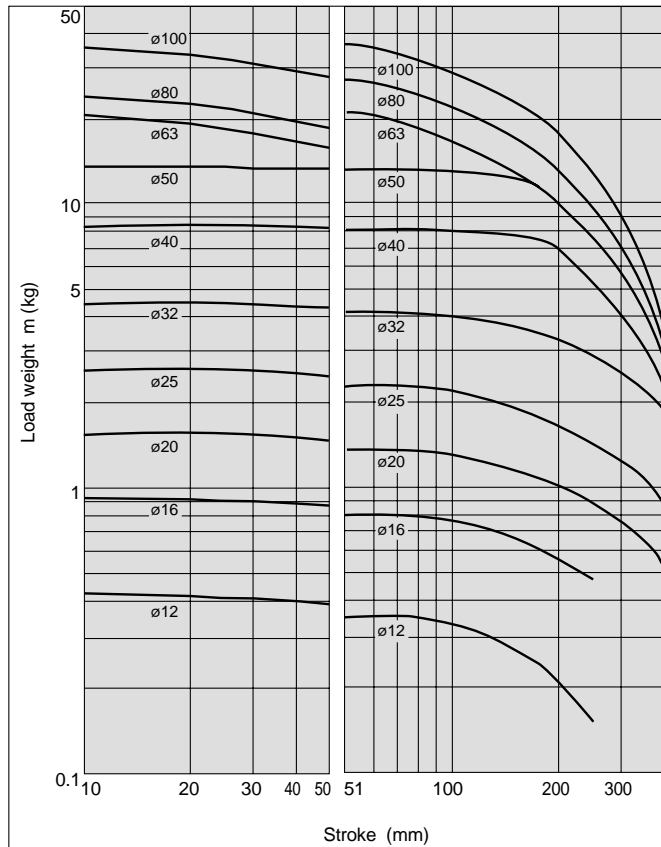

16 $\ell = 100\text{mm}$ $V = 400\text{mm/s}$

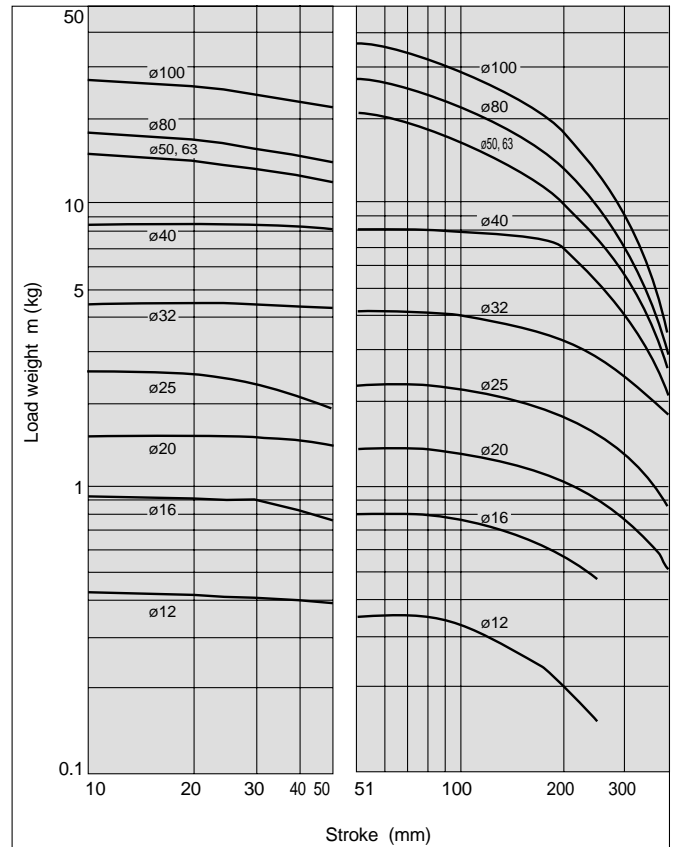

Horizontal Mounting **Ball Bushing**

17 / = 50mm V = 200m/s

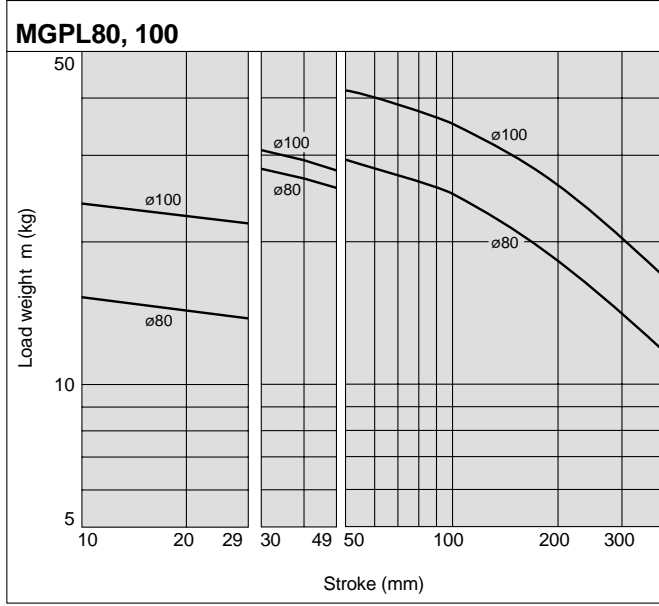
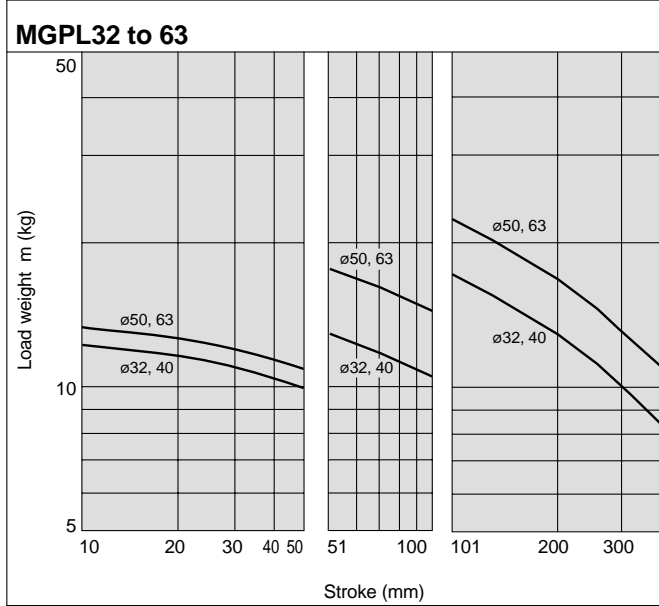
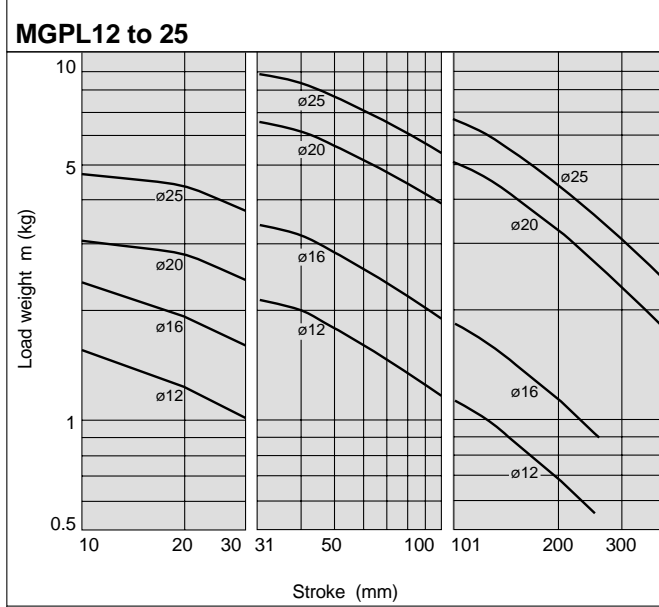

18 / = 100mm V = 200m/s

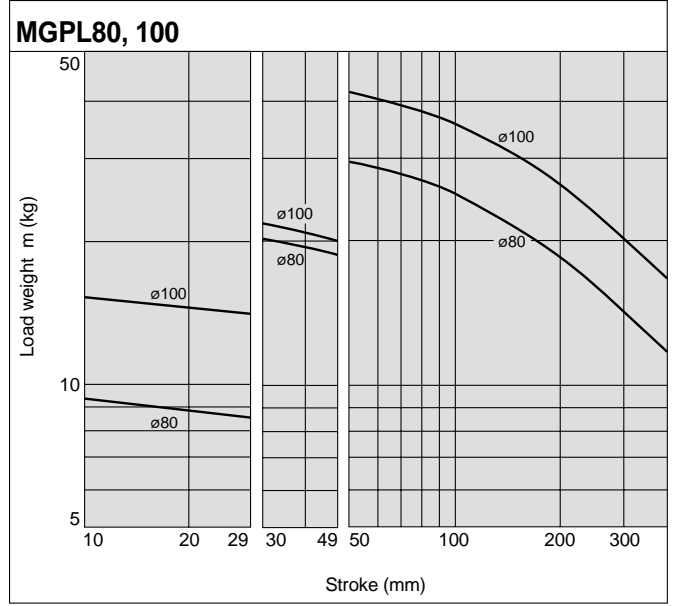
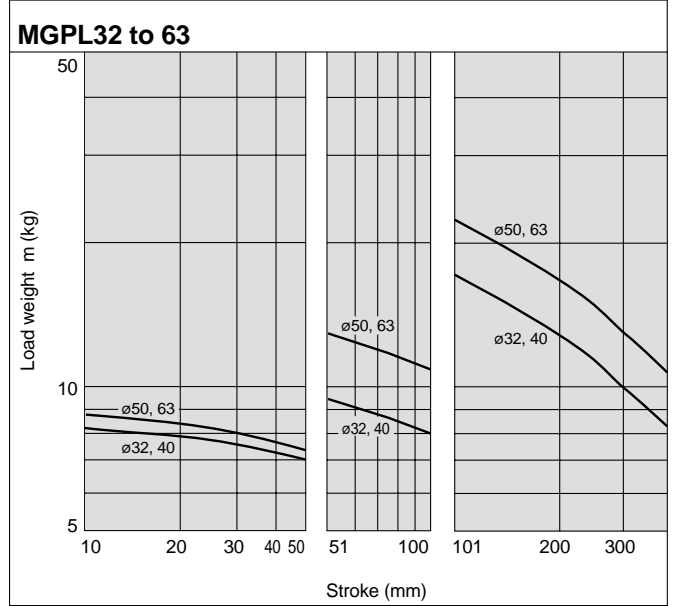
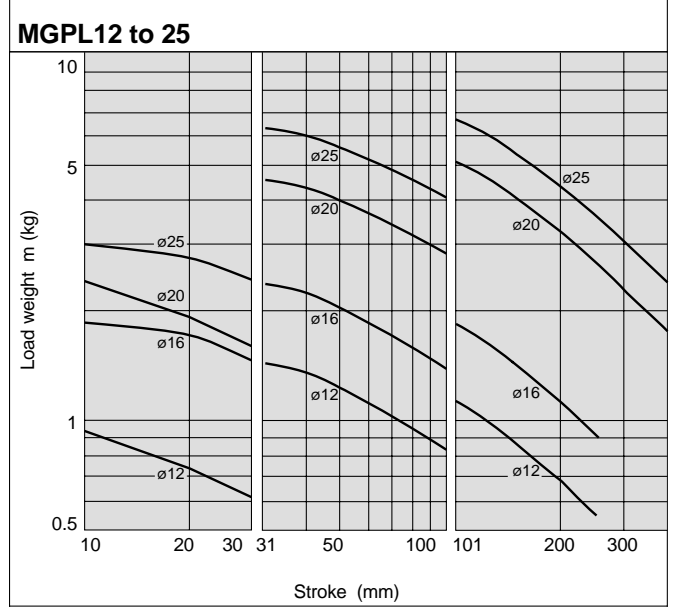

Standard Type
MGP

With Air Cushion
MGP

With End Lock
MGP

Heavy Duty
Guide Rod Type
MGPS

Order Made
Specifications

Auto Switches

Precautions

Series MGP

Horizontal Mounting **Ball Bushing**

19 $\varnothing = 50\text{mm}$ $V = 400\text{m/s}$

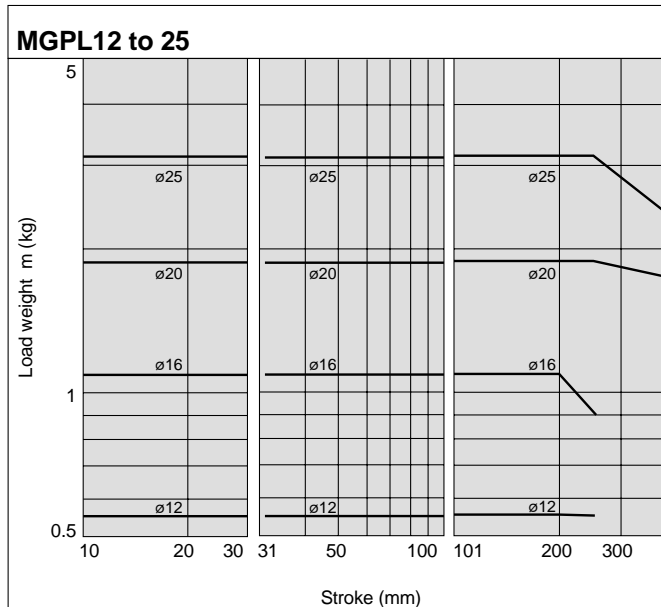

20 $\varnothing = 100\text{mm}$ $V = 400\text{m/s}$

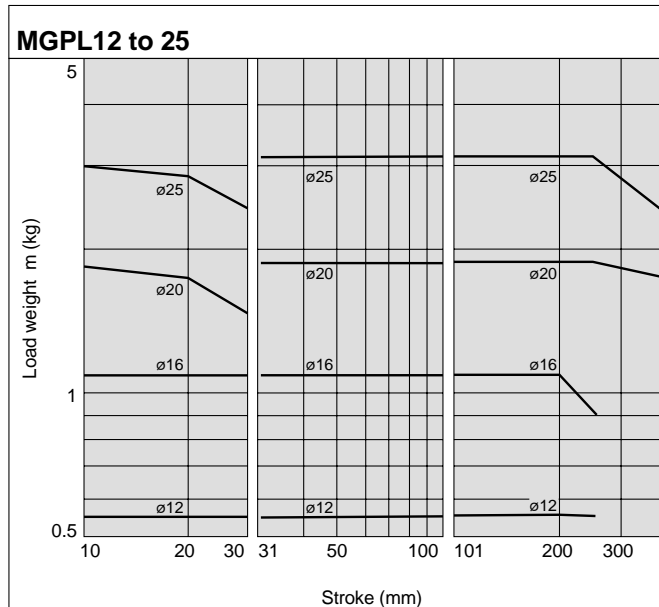

MGPL32 to 63

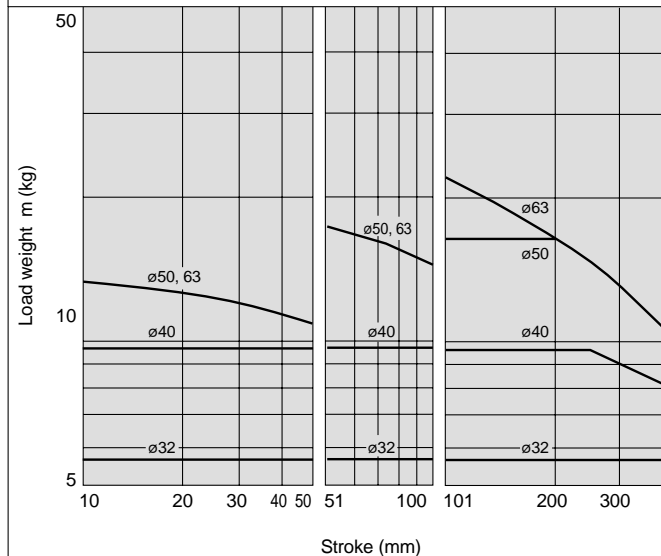

MGPL32 to 63

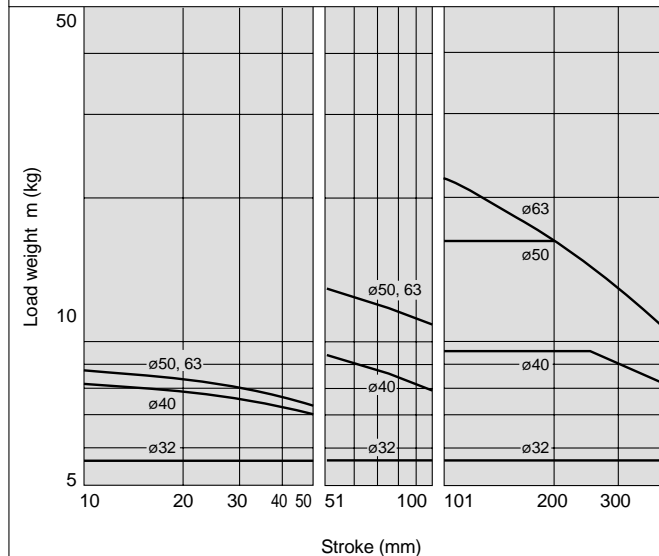

MGPL80, 100

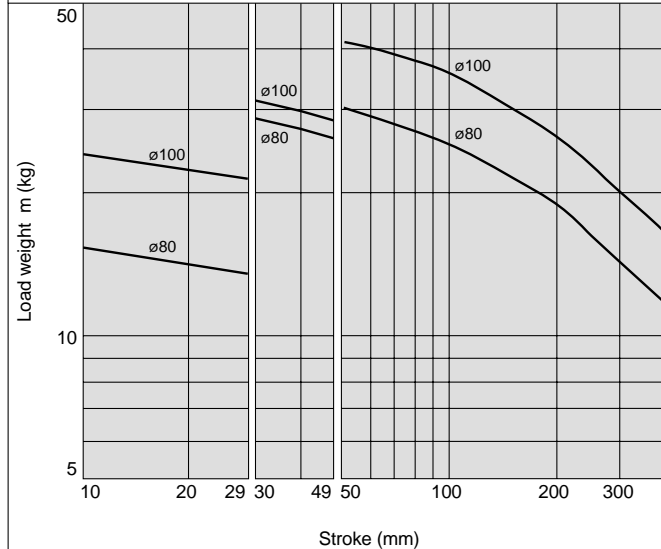

MGPL80, 100

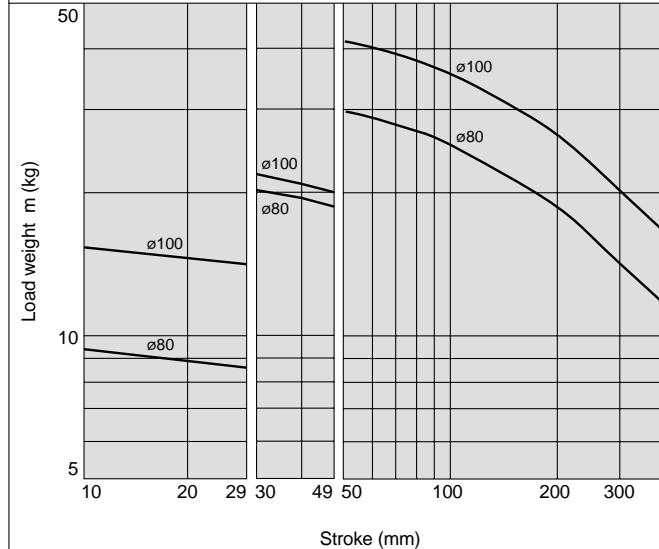

Operating Range when Used as Stopper

Bore Sizes $\phi 12$ to 25/MGPM12 to 25 (Slide bearing)

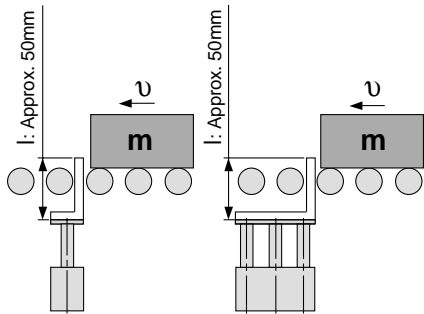

* When selecting a model with a longer l /dimension, be sure to choose a bore size which is sufficiently large.

⚠ Caution

Handling precautions

Note 1) When using as a stopper, select a model with a stroke of 30mm or less.

Note 2) Model MGPL (ball bushing) cannot be used as a stopper.

MGPM12 to 25 (Slide bearing)

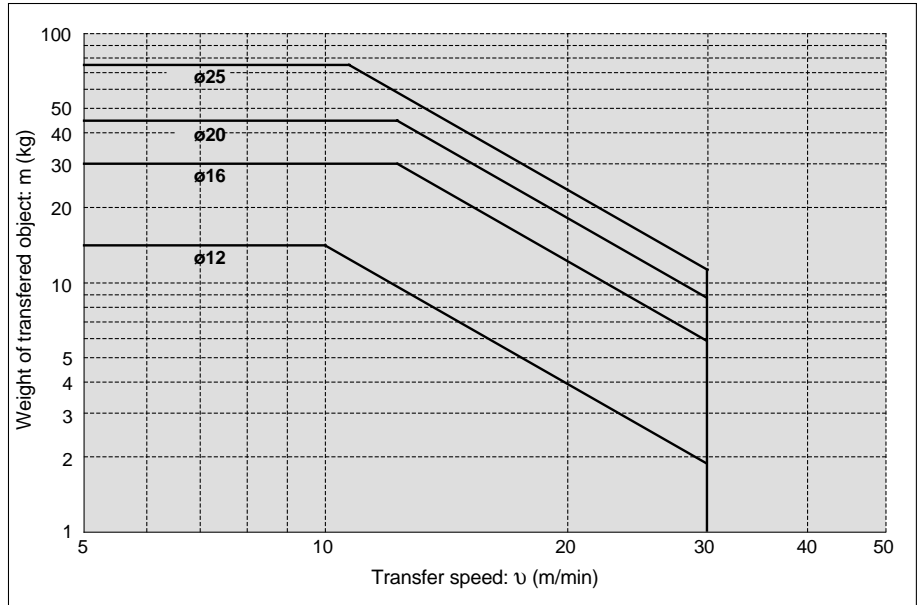

Bore Sizes $\phi 32$ to 100/MGPM32 to 100 (Slide bearing)

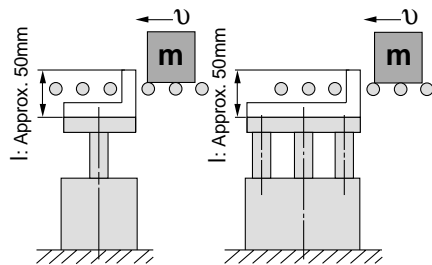

* When selecting a model with a longer l /dimension, be sure to choose a bore size which is sufficiently large.

⚠ Caution

Handling precautions

Note 1) When using as a stopper, select a model with a stroke of 50mm or less.

Note 2) Model MGPL (ball bushing) cannot be used as a stopper.

MGPM32 to 100 (Slide bearing)

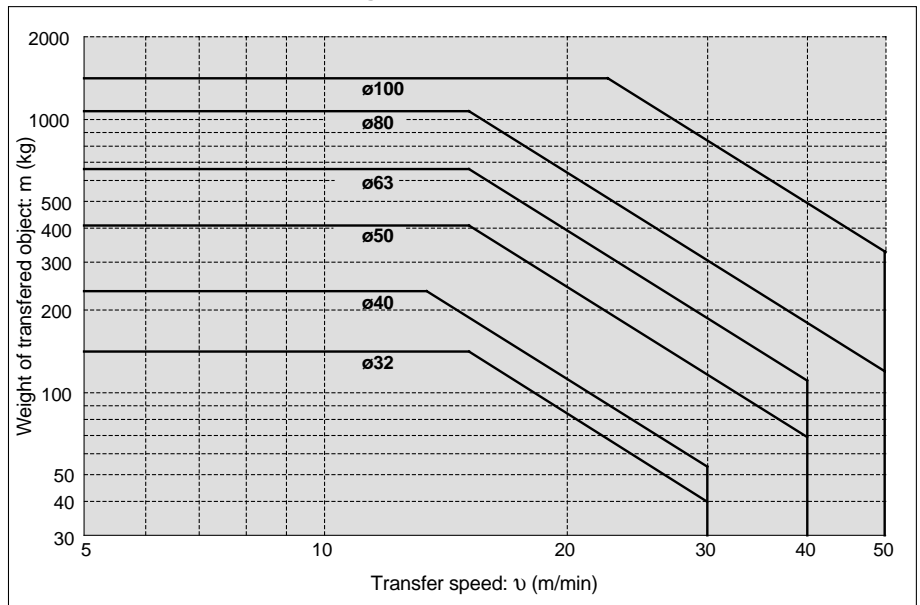

Series MGP

1. Water Resistant

Ideal for use in a machine tool environment exposed to coolants. Also applicable for use in an environment with water splashing such as food processing and car wash equipment, etc.

Specifications

Applicable series	MGPM	
Bearing type	Slide bearing	
Bore size (mm)	20, 25, 32, 40, 50, 63, 80, 100	
Cushion	MGPM□R	Rubber cushion
	MGPM□V	Without cushion

* Specifications other than above are identical to the standard basic type.

How to Order

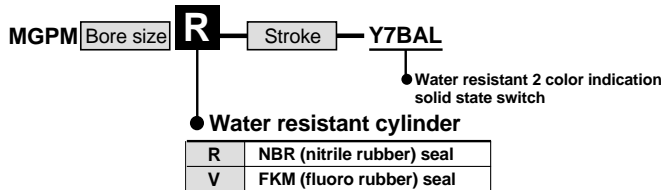

* Stainless steel parts are available as special order products.

Dimensions

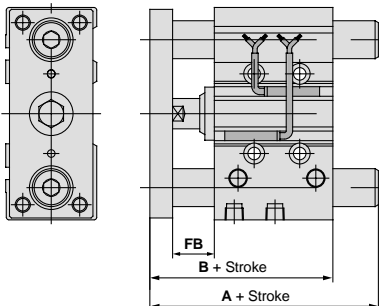

Bore size (mm)	A		B	FB
	50mm stroke or less	51mm stroke or more		
20	66	97.5	66	19
25	67.5	99	67.5	20
32	109	114	71.5	22
40	109	114	78	22
50	117.5	129	83	23
63	117.5	129	88	23
80	121	148	102.5	24
100	141	166	120	29

* Other dimensions are identical to the standard type.

2. Copper-free Series (applicable to CRT manufacturing process)

To prevent the influence of copper ions or halogen ions during CRT manufacturing processes, copper and fluorine materials are not used as component parts.

Specifications

Applicable series	MGPM	MGPL
Bearing type	Slide bearing	Ball bushing
Bore size (mm)	12, 16, 20, 25, 32, 40, 50, 63, 80, 100	

* Specifications and dimensions other than above are identical to the standard basic type.

How to Order

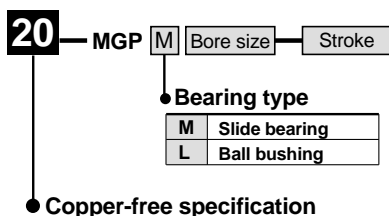

3. Clean Room Series

Applicable in a clean room environment.

Ideal for use in conveyor lines for semi-conductor (LSI), liquid crystal (LCD), food processing, pharmaceutical, and electronic parts, etc.

Specifications

Applicable series	MGPL							
Bearing type	Ball bushing							
Bore size (mm)	12	16	20	25	32	40	50	63
Stroke (mm)	10 to 100		20 to 200		25 to 200			

* Specifications other than above are identical to the standard basic type.

How to Order

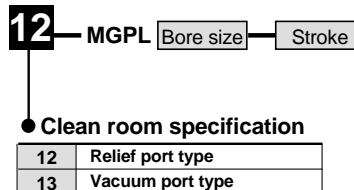

Dimensions

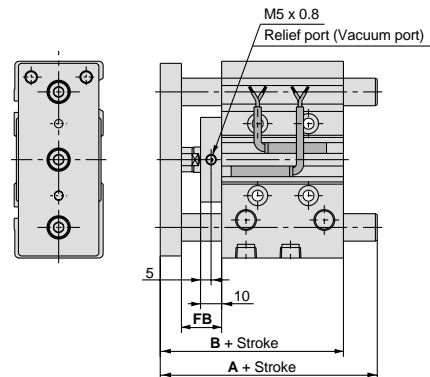

Bore size (mm)	A			B	FB
	30mm stroke or less	Over 30mm to 100mm stroke	Over 100mm stroke		
12	56	68	—	55	18
16	62	78	—	59	18
20	76	93	117	66	19
25	82.5	98.5	117.5	66.5	19

Bore size (mm)	A			B	FB
	50mm stroke or less	Over 50mm to 100mm stroke	Over 100mm stroke		
32	93	110	130	71.5	22
40	93	110	130	78	22
50	104	125	145	83	23
63	104	125	145	88	23

* Other dimensions are identical to the standard type.

Auto Switches/Proper Mounting Position for Stroke End Detection

Standard Type
MGP

With Air Cushion
MGP

With End Lock
MGP

Heavy Duty
Guide Rod Type
MGPS

Order Made
Specifications

Auto Switches

Precautions

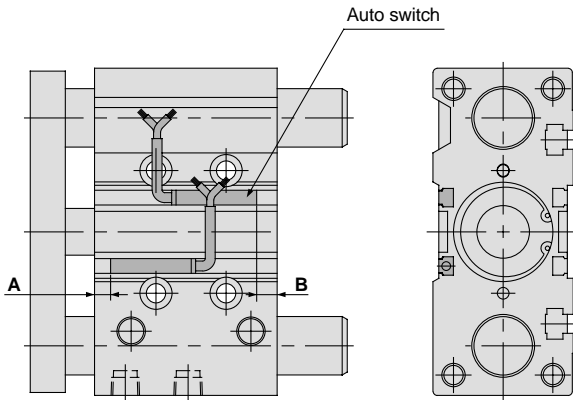

Proper mounting position (mm)

Bore size (mm)	A	B	Bore size (mm)	A	B
12	1.5	3	40	9.5	9.5
16	4.5	4	50	7.5	11.5
20	4	8	63	10	14
25	4.5	8	80	13	18.5
32	5.5	7	100	17.5	23.5

Note 1) Minimum mountable strokes for auto switch are 10mm or more for two switches, and 5mm or more for one switch.

Note 2) Type D-P5DW can be mounted only on bore sizes $\phi 40$ through $\phi 100$.

For D-P5DW (* Cannot be mounted on bore sizes $\phi 32$ or less.)

$\phi 40$ to $\phi 63$

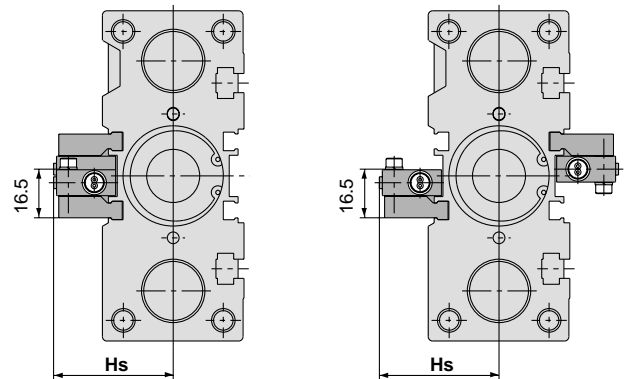

For 25mm stroke

* For bore sizes $\phi 40$ through 63 with two switches, one switch is mounted on each side.

$\phi 80, \phi 100$

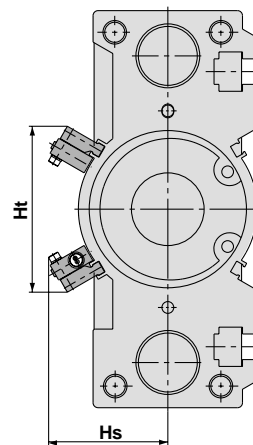

Bore size (mm)	Hs	Ht
40	44.5	—
50	50	—
63	57	—
80	60.7	84.4
100	70.8	96.1

* Minimum mountable strokes for auto switch are 10mm or more for two switches, and 5mm or more for one switch.

Auto Switch Mounting

⚠ Caution

Auto switch mounting tool

- When tightening the auto switch mounting screw (included with auto switch), use a watchmakers screw driver with a handle about 5 to 6mm in diameter.

Tightening torque

- Tighten with a torque of 0.05 to 0.1N·m. As a rule, it should be turned about 90° past the point at which tightening can be felt.

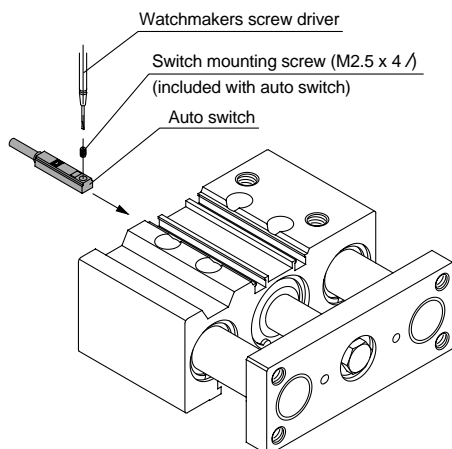

For D-P5DW

⚠ Caution

Auto switch mounting tool

- When tightening hexagon socket head cap screws of the auto switch, use hexagon wrench key 2 or 2.5 with the appropriate screws.

Tightening torque

- Tighten M2.5 screws with a torque of about 0.3 to 0.5N·m, and M3 screws with a torque of about 0.5 to 0.7 N·m.

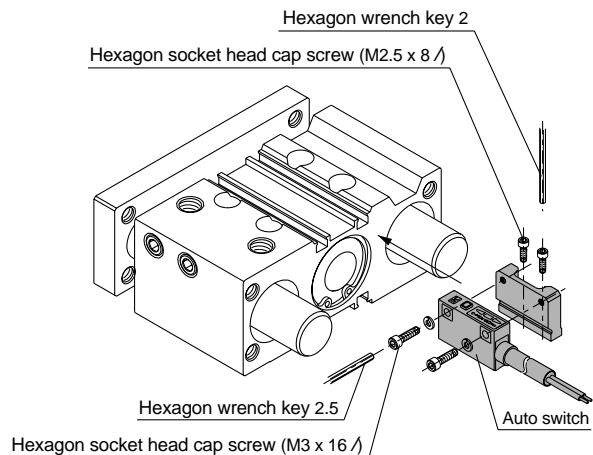

Series MGP

Construction

Series MGPM

Series MGPL

MGPM12 to 25

MGPL12 to 25

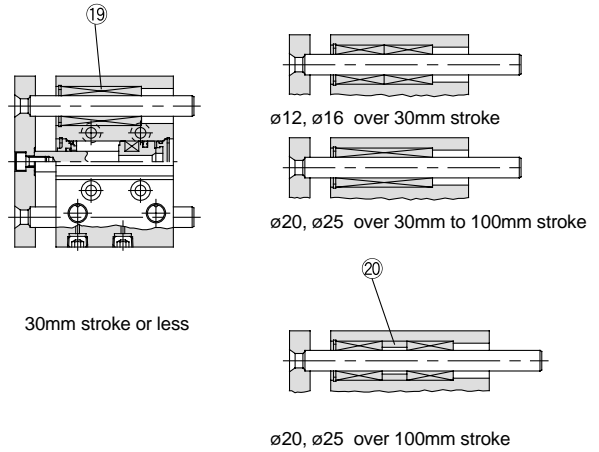
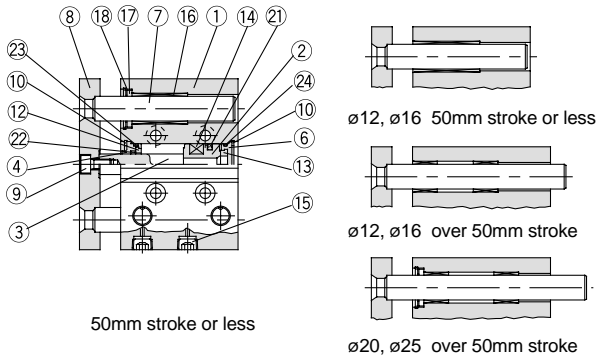

MGPM32 to 100

MGPL32 to 100

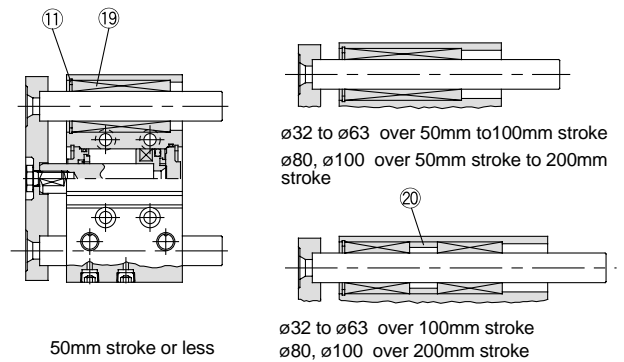
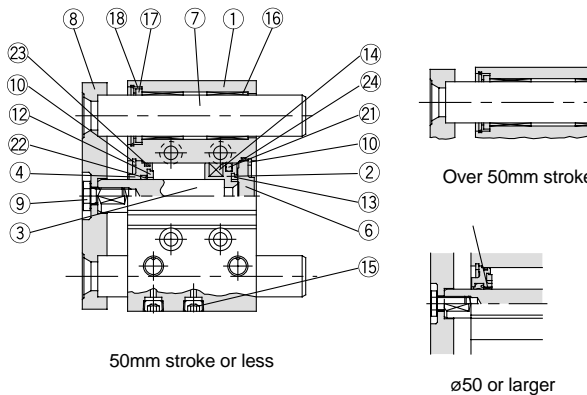

Parts list

No.	Description	Material	Note
1	Body	Aluminum alloy	Hard anodized
2	Piston	Aluminum alloy	Chromated
3	Piston rod	Stainless steel	ø12 to ø25
		Carbon steel	ø32 to ø100 Hard chrome plated
4	Collar	Aluminum bearing alloy	ø12 to ø40 Clear anodized
		Aluminum alloy casting	ø50 to ø100 Coated
5	Bushing	Lead bronze casting	ø50 to ø100
6	Head cover	Aluminum alloy	ø12 to ø63 ø80 to ø100 Clear chromated Coated
7	Guide rod	Carbon steel	Hard chrome plated
8	Plate	Carbon steel	Nickel plated
9	Plate mounting bolt	Carbon steel	Nickel plated
10	Snap ring	Carbon tool steel	Phosphate coated
11	Snap ring	Carbon tool steel	Phosphate coated

Replacement parts: Seal kits

Bore size (mm)	Order No.	Contents
12	MGP12-PS	Kits include items 21, 22, 23, and 24 from the table above.
16	MGP16-PS	
20	MGP20-PS	
25	MGP25-PS	
32	MGP32-PS	

* Seal kits are sets consisting of items 21 through 24 above, and can be ordered using the order number for each bore size.

Parts list

No.	Description	Material	Note
12	Bumper A	Urethane	
13	Bumper B	Urethane	
14	Magnet	Synthetic rubber	
15	Plug (M-5P) Hexagon socket head taper plug	Brass	ø12, ø16 Nickel plated
		Carbon steel	ø20 to ø100 Nickel plated
16	Slide bearing	Lead bronze casting	
17	Felt	Felt	
18	Holder	Resin	
19	Ball bushing		
20	Spacer	Aluminum alloy	
21*	Piston seal	NBR	
22*	Rod seal	NBR	
23*	Gasket A	NBR	
24*	Gasket B	NBR	

Replacement parts: Seal kits

Bore size (mm)	Order no.	Contents
40	MGP40-PS	Kits include items 21, 22, 23, and 24 from the table above.
50	MGP50-PS	
63	MGP63-PS	
80	MGP80-PS	
100	MGP100-PS	

∅12 to ∅25/MGPM, MGPL

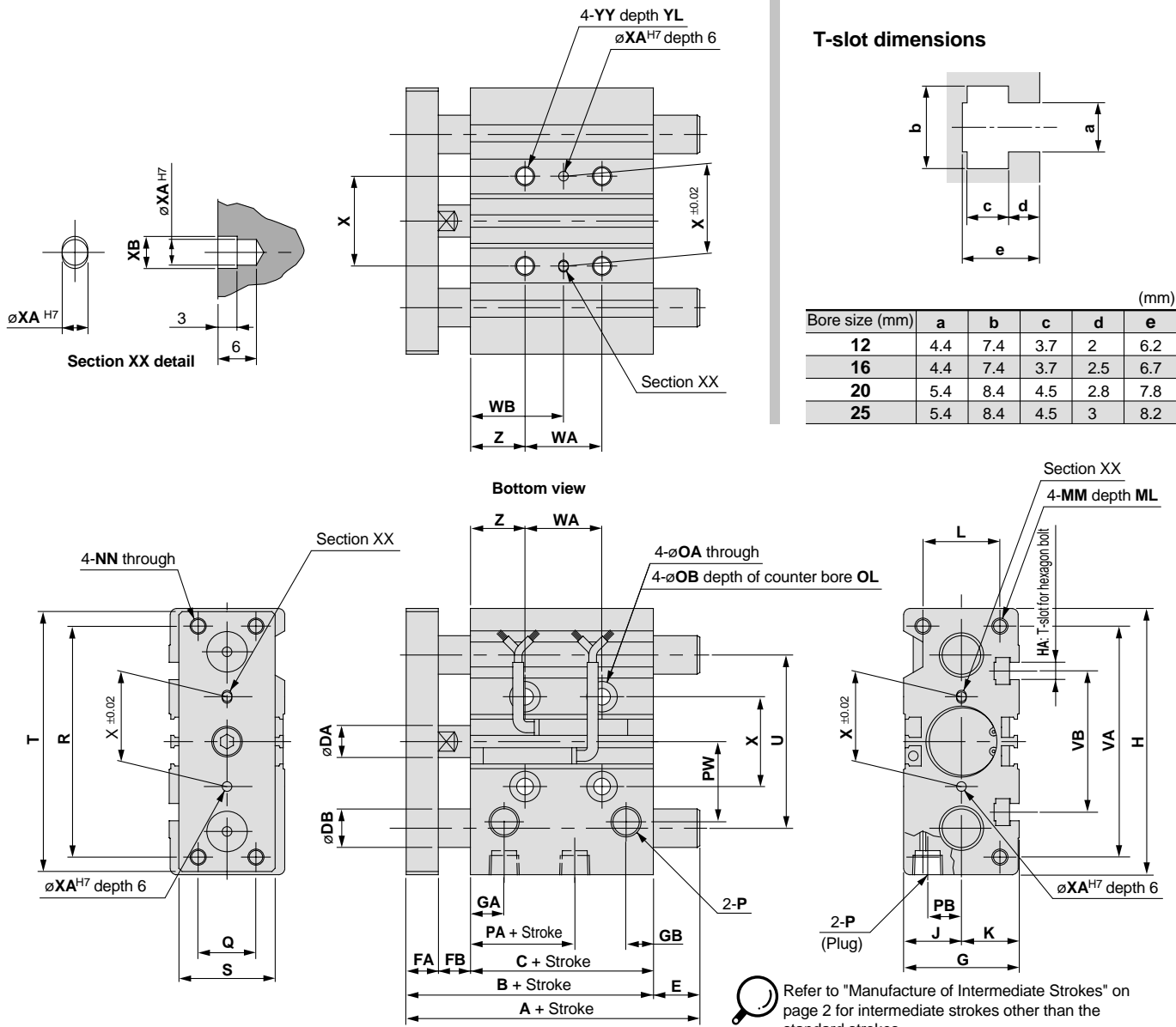

T-slot dimensions (mm)

Bore size (mm)	a	b	c	d	e
12	4.4	7.4	3.7	2	6.2
16	4.4	7.4	3.7	2.5	6.7
20	5.4	8.4	4.5	2.8	7.8
25	5.4	8.4	4.5	3	8.2

MGPM, MGPL Common dimensions

Bore size (mm)	Standard stroke (mm)	B	C	DA	FA	FB	G	GA	GB	H	HA	J	K	L	MM	ML	NN	OA	OB	OL	P	PA	PB	PW
12	10, 20, 30, 40, 50, 75, 100	42	29	6	8	5	26	11	7.5	58	M4	13	13	18	M4 x 0.7	10	M4 x 0.7	4.3	8	4.5	M5 x 0.8	13	8	18
16	125, 150, 175, 200, 250	46	33	8	8	5	30	11	8	64	M4	15	15	22	M5 x 0.8	12	M5 x 0.8	4.3	8	4.5	M5 x 0.8	15	10	19
20	20, 30, 40, 50, 75, 100, 125, 150, 175, 200, 250, 300, 350, 400	53	37	10	10	6	36	10.5	8.5	83	M5	18	18	24	M5 x 0.8	13	M5 x 0.8	5.6	9.5	5.5	Rc 1/8	12.5	10.5	25
25		53.5	37.5	12	10	6	42	11.5	9	93	M5	21	21	30	M6 x 1.0	15	M6 x 1.0	5.6	9.5	5.5	Rc 1/8	12.5	13.5	28.5

Bore size (mm)	Q	R	S	T	U	VA	VB	WA					WB					X	XA	XB	YY	YL	Z
								30st or less	Over 30st to 100st	Over 100st to 200st	Over 200st to 300st	Over 300st	30st or less	Over 30st to 100st	Over 100st to 200st	Over 200st to 300st	Over 300st						
12	14	48	22	56	41	50	37	20	40	110	200	—	15	25	60	105	—	23	3	3.5	M5 x 0.8	10	5
16	16	54	25	62	46	56	38	24	44	110	200	—	17	27	60	105	—	24	3	3.5	M5 x 0.8	10	5
20	18	70	30	81	54	72	44	24	44	120	200	300	29	39	77	117	167	28	3	3.5	M6 x 1.0	12	17
25	26	78	38	91	64	82	50	24	44	120	200	300	29	39	77	117	167	34	4	4.5	M6 x 1.0	12	17

MGPM (slide bearing)/Dimensions A, DB, E (mm)

Bore size (mm)	A			DB	E		
	50st or less	Over 50st to 100st	Over 100st		50st or less	Over 50st to 100st	Over 100st
12	42	60.5	85	8	0	18.5	43
16	46	64.5	95	10	0	18.5	49

MGPL (ball bushing)/Dimensions A, DB, E (mm)

Bore size (mm)	A			DB	E		
	30st or less	Over 30st to 100st	Over 100st		30st or less	Over 30st to 100st	Over 100st
12	43	55	85	6	1	13	43
16	49	65	95	8	3	19	49

MGPM (slide bearing)/Dimensions A, DB, E (mm)

Bore size (mm)	A			DB	E		
	50st or less	Over 50st to 200st	Over 200st		50st or less	Over 50st to 200st	Over 200st
20	53	84.5	122	12	0	31.5	69
25	53.5	85	122	16	0	31.5	68.5

MGPL (ball bushing)/Dimensions A, DB, E (mm)

Bore size (mm)	A				DB	E			
	30st or less	Over 30st to 100st	Over 100st to 200st	Over 200st		30st or less	Over 30st to 100st	Over 100st to 200st	Over 200st
20	63	80	104	122	10	10	27	51	69
25	69.5	85.5	104.5	122	13	16	32	51	68.5

Refer to "Manufacture of Intermediate Strokes" on page 2 for intermediate strokes other than the standard strokes.

Standard Type MGP
 With Air Cushion MGP
 With End Lock MGP
 Heavy Duty Guide Rod Type MGPS
 Order Made Specifications
 Auto Switches
 Precautions

Series MGP

Ø32 to Ø63/MGPM, MGPL

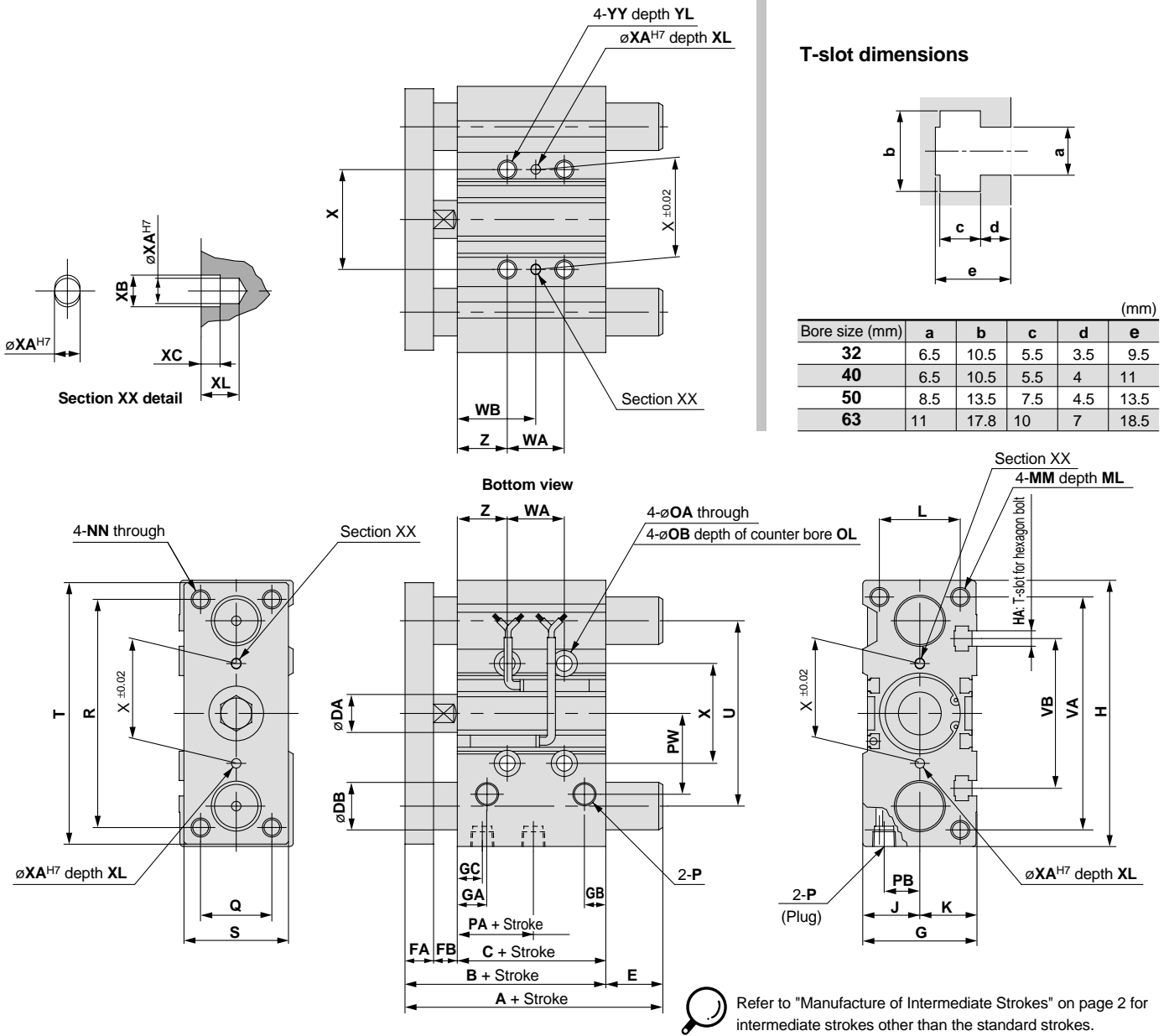

MGPM, MGPL Common dimensions

Bore size (mm)	Standard stroke (mm)	B	C	DA	FA	FB	G	GA	GB	GC	H	HA	J	K	L	MM	ML	NN	OA	OB	OL	P	PA	PB	PW	Q
32	25, 50, 75, 100, 125, 150, 175, 200, 250, 300, 350, 400	59.5	37.5	16	12	10	48	12.5	9	12.5	112	M6	24	24	34	M8 x 1.25	20	M8 x 1.25	6.6	11	7.5	Rc 1/8	7	15	34	30
40		66	44	16	12	10	54	14	10	14	120	M6	27	27	40	M8 x 1.25	20	M8 x 1.25	6.6	11	7.5	Rc 1/8	13	18	38	30
50		72	44	20	16	12	64	14	11	12	148	M8	32	32	46	M10 x 1.5	22	M10 x 1.5	8.6	14	9	Rc 1/4	9	21.5	47	40
63		77	49	20	16	12	78	16.5	13.5	16.5	162	M10	39	39	58	M10 x 1.5	22	M10 x 1.5	8.6	14	9	Rc 1/4	14	28	55	50

Bore size (mm)	R	S	T	U	VA	VB	WA					WB					X	XA	XB	XC	XL	YY	YL	Z
							25st or less	Over 25st to 100st	Over 100st to 200st	Over 200st to 300st	Over 300st	25st or less	Over 25st to 100st	Over 100st to 200st	Over 200st to 300st	Over 300st								
32	96	44	110	78	98	63	24	48	124	200	300	33	45	83	121	171	42	4	4.5	3	6	M8 x 1.25	16	21
40	104	44	118	86	106	72	24	48	124	200	300	34	46	84	122	172	50	4	4.5	3	6	M8 x 1.25	16	22
50	130	60	146	110	130	92	24	48	124	200	300	36	48	86	124	174	66	5	6	4	8	M10 x 1.5	20	24
63	130	70	158	124	142	110	28	52	128	200	300	38	50	88	124	174	80	5	6	4	8	M10 x 1.5	20	24

MGPM (slide bearing)/Dimensions A, DB, E

Bore size (mm)	A			DB	E		
	50st or less	Over 50st to 200st	Over 200st		50st or less	Over 50st to 200st	Over 200st
32	97	102	140	20	37.5	42.5	80.5
40	97	102	140	20	31	36	74
50	106.5	118	161	25	34.5	46	89
63	106.5	118	161	25	29.5	41	84

MGPL (ball bushing)/Dimensions A, DB, E

Bore size (mm)	A				DB	E			
	50st or less	Over 50st to 100st	Over 100st to 200st	Over 200st		50st or less	Over 50st to 100st	Over 100st to 200st	Over 200st
32	81	98	118	140	16	21.5	38.5	58.5	80.5
40	81	98	118	140	16	15	32	52	74
50	93	114	134	161	20	21	42	62	89
63	93	114	134	161	20	16	37	57	84

ø80, ø100/MGPM, MGPL

Standard Type
MGP

With Air Cushion
MGP

With End Lock
MGP

Heavy Duty
Guide Rod Type
MGPS

Order Made
Specifications

Auto Switches

Precautions

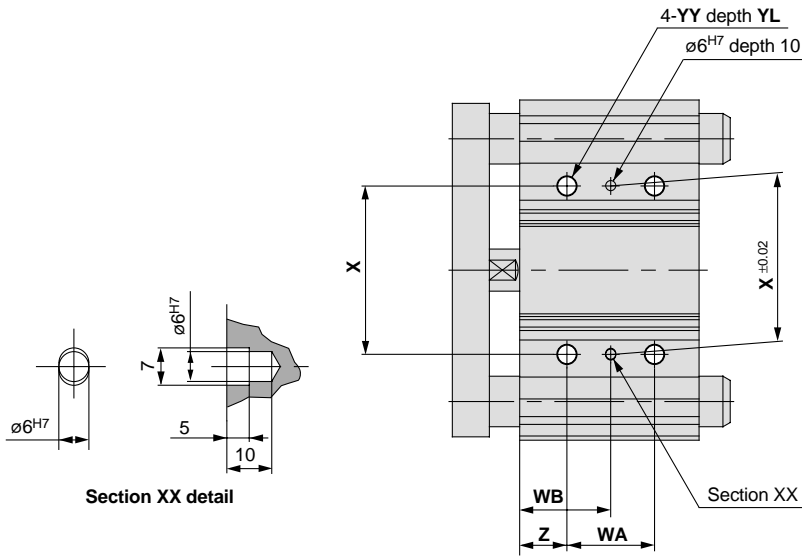

T-slot dimensions

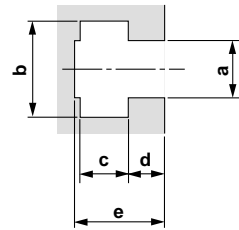

Bore size (mm)	a	b	c	d	e
80	13.3	20.3	12	8	22.5
100	15.3	23.3	13.5	10	30

Bottom view

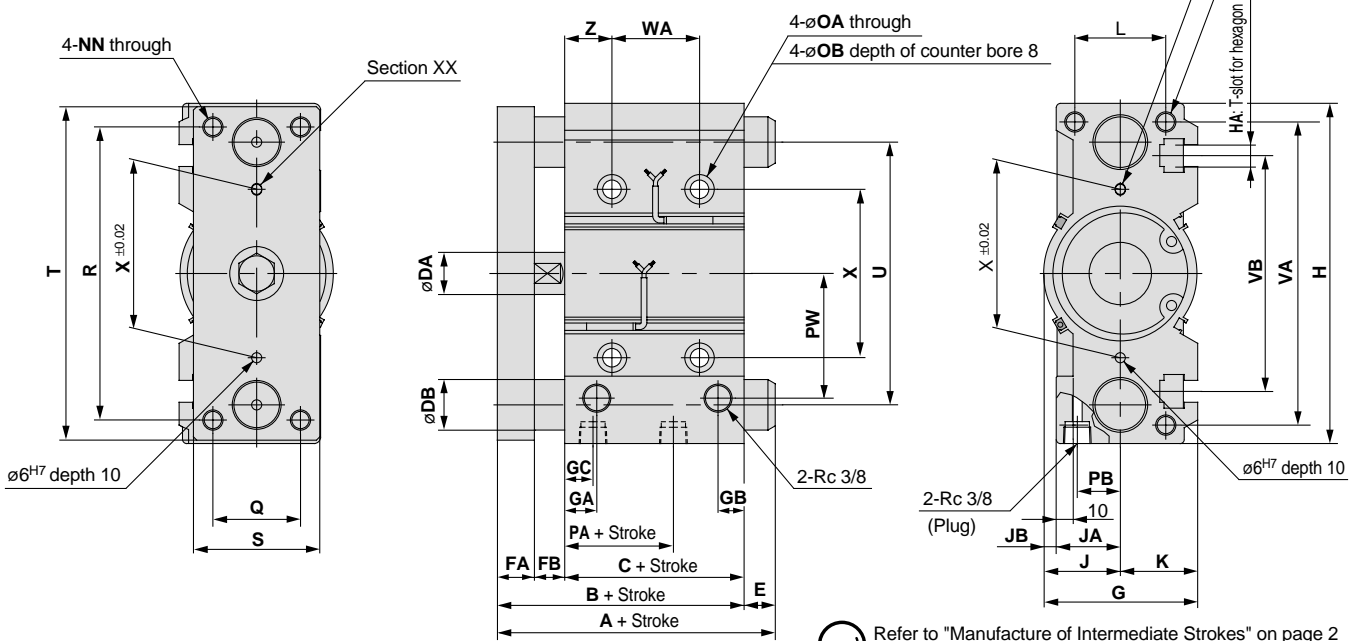

Refer to "Manufacture of Intermediate Strokes" on page 2 for intermediate strokes other than the standard strokes.

MGPM, MGPL Common dimensions

Bore size (mm)	Standard stroke (mm)	B	C	DA	FA	FB	G	GA	GB	GC	H	HA	J	JA	JB	K	L	MM	ML	NN	OA	OB	PA	PB	PW	Q	R
80	25, 50, 75, 100, 125, 150, 175, 200	96.5	56.5	25	22	18	91.5	19	15.5	14.5	202	M12	45.5	38	7.5	46	54	M12 x 1.75	25	M12 x 1.75	10.6	17.5	14.5	25.5	74	52	174
100	250, 300, 350, 400	116	66	30	25	25	111.5	23	19	18	240	M14	55.5	45	10.5	56	62	M14 x 2.0	31	M14 x 2.0	12.5	20	17.5	32.5	89	64	210

Bore size (mm)	S	T	U	VA	VB	WA					WB					X	YY	YL	Z
						25st or less	Over 25st to 100st	Over 100st to 200st	Over 200st to 300st	Over 300st	25st or less	Over 25st to 100st	Over 100st to 200st	Over 200st to 300st	Over 300st				
80	75	198	156	180	140	28	52	128	200	300	42	54	92	128	178	100	M12 x 1.75	24	28
100	90	236	188	210	166	48	72	148	220	320	35	47	85	121	171	124	M14 x 2.0	28	11

MGPM (slide bearing)/Dimensions A, DB, E (mm)

Bore size (mm)	A			DB	E		
	50st or less	Over 50st to 200st	Over 200st		50st or less	Over 50st to 200st	Over 200st
80	115	142	193	30	18.5	45.5	96.5
100	137	162	203	36	21	46	87

MGPL (ball bushing)/Dimensions A, DB, E (mm)

Bore size (mm)	A				DB	E			
	25st or less	Over 25st to 50st	Over 50st to 200st	Over 200st		25st or less	Over 25st to 50st	Over 50st to 200st	Over 200st
80	109.5	130	160	193	25	13	33.5	63.5	96.5
100	121	147	180	203	30	5	31	64	87

Compact Guide Cylinder: With Air Cushion

Series *MGP*

ø16, ø20, ø25, ø32, ø40, ø50, ø63, ø80, ø100

How to Order

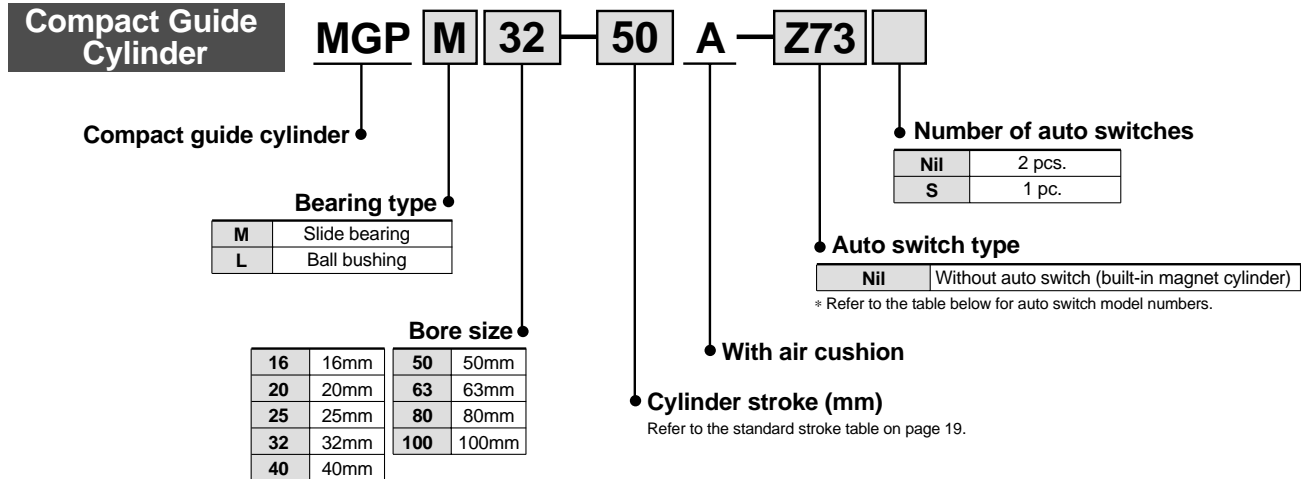

Applicable auto switches

Type	Special function	Electrical entry	Indicator light	Wiring (output)	Load voltage		Auto switch model		Lead wire length (m) ^{Note 1)}			Applicable load		Detailed specifications	
					DC	AC	Electrical entry direction		0.5 (Nil)	3 (L)	5 (Z)	IC circuit	Relay, PLC		
						Perpendicular	In-line								
Reed switch	—	Grommet	Yes	3 wire	—	5V	—	—	Z76	●	●	—	IC circuit	—	P. 59
				2 wire	12V	100V	—	Z73	●	●	●	—	Relay, PLC		
					5V 12V	100V or less	—	Z80	●	●	—	IC circuit	—		
Solid state switch	—	Grommet	Yes	3 wire (NPN)	24V	5V 12V	—	Y69A	Y59A	●	●	○	IC circuit	Relay, PLC	P. 60
				3 wire (PNP)		—		Y7PV	Y7P	●	●	○			
				2 wire		12V		Y69B	Y59B	●	●	○	—		
				3 wire (NPN)		5V 12V		Y7NWV	Y7NW	●	●	○	IC circuit		
				3 wire (PNP)		—		Y7PWV	Y7PW	●	●	○	—		
				2 wire		12V		Y7BWV	Y7BW	●	●	○	—		
	Water resistant (2 color indicator)	—	—	Y7BA	—	●	○	—	P. 62						
Magnetic field resistant (2 color indicator)	—	—	^{Note 3)} P5DW	—	●	●	—	P. 63							

Note 1) Lead wire symbols 0.5m Nil (Example) Y69B
3m L Y69BL
5m Z Y69BZ

Note 2) Solid state auto switches marked with a "○" are produced upon receipt of order.

Note 3) Type D-P5DW cannot be mounted on bore sizes of ø32 or less.

Specifications



Action	Double acting	
Fluid	Air	
Proof pressure	1.5MPa	
Maximum operating pressure	1.0MPa	
Minimum operating pressure	ø16	0.15MPa
	ø20 to ø100	0.12MPa
Ambient and fluid temperature	-10 to 60°C (with no freezing)	
Piston speed	ø16 to ø63	50 to 500mm/s
	ø80, ø100	50 to 400mm/s
Cushion	Air cushion at both ends (without bumper)	
Lubrication	Non-lube	
Stroke length tolerance	+1.5 0 mm	

Standard Strokes

Bore size (mm)	Standard stroke (mm)
16	25, 50, 75, 100
20 to 63	25, 50, 75, 100, 125, 150, 175, 200
80, 100	50, 75, 100, 125, 150, 175, 200

Manufacture of Intermediate Strokes

Modification method	Strokes provided in 1mm increments by changing the collar on a standard stroke cylinder.	
Part number	Indicate -XC19 at the end of the standard part number.	
Applicable stroke (mm)	ø16	26 to 99
	ø20 to ø63	26 to 199
	ø80, ø100	51 to 199
Example	Part no.: MGPM20-35A-XC19 A collar 15mm in width is installed in a MGPM20-50A . C dimension is 112mm.	

Note 1) Intermediate strokes (in 1mm increments) with a special body are available by special order.

Auto switch mounting bracket part no. for D-P5DW

Bore size (mm)	Mounting bracket part no.	Notes
40, 50, 63, 80, 100	BMG1-040	Switch mounting bracket Hexagon socket head cap screw (M2.5 x 0.45 x 8 /) 2 pcs. Hexagon socket head cap screw (M3 x 0.5 x 16 /) 2 pcs. Spring washer (nominal size 3)

Theoretical Output

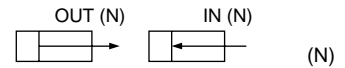

Bore size (mm)	Rod size (mm)	Operating direction	Piston area (mm ²)	Operating pressure (MPa)										
				0.2	0.3	0.4	0.5	0.6	0.7	0.8	0.9	1.0		
16	8	OUT	201	40	60	80	101	121	141	161	181	201		
		IN	151	30	45	60	76	91	106	121	136	151		
20	10	OUT	314	63	94	126	157	188	220	251	283	314		
		IN	236	47	71	94	118	142	165	189	212	236		
25	12	OUT	491	98	147	196	246	295	344	393	442	491		
		IN	378	76	113	151	189	227	265	302	340	378		
32	16	OUT	804	161	241	322	402	482	563	643	724	804		
		IN	603	121	181	241	302	362	422	482	543	603		
40	16	OUT	1257	251	377	503	629	754	880	1006	1131	1257		
		IN	1056	211	317	422	528	634	739	845	950	1056		
50	20	OUT	1963	393	589	785	982	1178	1374	1570	1767	1963		
		IN	1649	330	495	660	825	990	1154	1319	1484	1649		
63	20	OUT	3117	623	935	1247	1559	1870	2182	2494	2805	3117		
		IN	2803	561	841	1121	1402	1682	1962	2242	2523	2803		
80	25	OUT	5027	1005	1508	2011	2514	3016	3519	4022	4524	5027		
		IN	4536	907	1361	1814	2268	2722	3175	3629	4082	4536		
100	30	OUT	7854	1571	2356	3142	3927	4712	5498	6283	7069	7854		
		IN	7147	1429	2144	2859	3574	4288	5003	5718	6432	7147		

Note) Theoretical output (N) = Pressure (MPa) x Piston area (mm²)

Series MGP

Weights

Slide bearing: MGPM16 to 100

(kg)

Bore size (mm)	Model	Standard stroke (mm)							
		25	50	75	100	125	150	175	200
16	MGPM16	0.51	0.69	0.78	0.91	—	—	—	—
20	MGPM20	0.89	1.14	1.34	1.54	1.74	1.94	2.13	2.33
25	MGPM25	1.23	1.60	1.87	2.14	2.41	2.68	2.95	3.23
32	MGPM32	1.98	2.51	2.77	3.15	3.53	3.91	4.29	4.68
40	MGPM40	2.34	2.91	3.21	3.64	4.06	4.49	4.92	5.34
50	MGPM50	3.92	4.75	5.29	5.93	6.57	7.21	7.85	8.49
63	MGPM63	4.94	5.89	6.54	7.29	8.05	8.81	9.56	10.32
80	MGPM80	—	8.98	9.64	10.6	11.5	12.5	13.4	14.3
100	MGPM100	—	14.2	15.1	16.5	17.8	19.1	20.5	21.8

Ball bushing: MGPL16 to 100

(kg)

Bore size (mm)	Model	Standard stroke (mm)							
		25	50	75	100	125	150	175	200
16	MGPL16	0.56	0.66	0.78	0.89	—	—	—	—
20	MGPL20	0.97	1.12	1.30	1.50	1.68	1.85	2.03	2.20
25	MGPL25	1.34	1.54	1.78	2.05	2.28	2.51	2.74	2.97
32	MGPL32	1.81	2.34	2.57	2.94	3.26	3.58	3.89	4.21
40	MGPL40	2.15	2.73	3.01	3.42	3.78	4.14	4.50	4.86
50	MGPL50	3.65	4.47	4.95	5.71	6.14	6.69	7.24	7.79
63	MGPL63	4.66	5.60	6.20	7.07	7.61	8.28	8.95	9.61
80	MGPL80	—	8.88	9.63	10.5	11.3	12.1	12.9	13.7
100	MGPL100	—	13.7	14.9	16.0	17.2	18.4	19.6	20.8

Allowable Rotational Torque of Plate (Air Cushion)

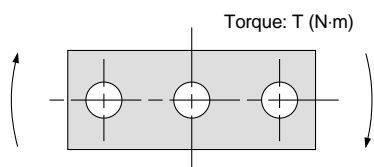

T (N·m)

Bore size (mm)	Bearing type	Stroke (mm)							
		25	50	75	100	125	150	175	200
16	MGPM	0.53	0.84	0.69	0.58	—	—	—	—
	MGPL	1.27	0.86	0.65	0.52	—	—	—	—
20	MGPM	0.99	2.23	1.88	1.63	1.44	1.28	1.16	1.06
	MGPL	2.66	1.94	1.52	1.57	1.34	1.17	1.03	0.93
25	MGPM	1.64	3.51	2.96	2.57	2.26	2.02	1.83	1.67
	MGPL	4.08	3.02	2.38	2.41	2.05	1.78	1.58	1.41
32	MGPM	6.35	6.64	5.69	4.97	4.42	3.98	3.61	3.31
	MGPL	5.95	5.89	5.11	6.99	6.34	5.79	5.33	4.93
40	MGPM	7.00	7.32	6.27	5.48	4.87	4.38	3.98	3.65
	MGPL	6.55	6.49	5.62	7.70	6.98	6.38	5.87	5.43
50	MGPM	13.0	13.8	12.0	10.6	9.50	8.60	7.86	7.24
	MGPL	9.17	11.2	9.8	12.8	11.6	10.7	9.80	9.10
63	MGPM	14.7	15.6	13.5	11.9	10.7	9.69	8.86	8.16
	MGPL	10.2	12.5	11.0	14.3	13.0	11.9	11.0	10.2
80	MGPM	—	26.0	22.9	20.5	18.6	17.0	15.6	14.5
	MGPL	—	25.2	22.7	20.6	18.9	17.3	16.0	14.8
100	MGPM	—	41.9	37.5	33.8	30.9	28.4	26.2	24.4
	MGPL	—	41.7	37.9	34.6	31.8	29.3	27.2	25.3

Non-rotating Accuracy of Plate

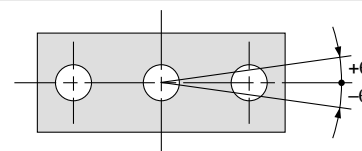

For non-rotating accuracy θ without load, use a value no more than the values in the table as a guide.

Bore size (mm)	Non-rotating accuracy θ	
	MGPM	MGPL
16	$\pm 0.08^\circ$	$\pm 0.10^\circ$
20	$\pm 0.07^\circ$	$\pm 0.09^\circ$
25		
32	$\pm 0.06^\circ$	$\pm 0.08^\circ$
40		
50	$\pm 0.05^\circ$	$\pm 0.06^\circ$
63		
80	$\pm 0.04^\circ$	$\pm 0.05^\circ$
100		

Series MGP (With Air Cushion) Model Selection

Selecting Conditions

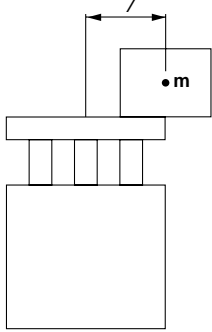
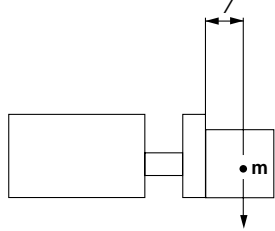
Mounting orientation	Vertical		Horizontal	
				
Maximum speed (mm/s)	200	400	200	400
Graph (Slide bearing type)	1, 2	3, 4	15, 16	17, 18
Graph (Ball bushing type)	5 to 9	10 to 14	19, 20	21, 22

Selection Example 1 (Vertical Mounting)

Selecting conditions
 Mounting: Vertical
 Bearing type: Ball bushing
 Stroke: 75mm
 Maximum speed: 200mm/s
 Load weight: 7kg
 Eccentric distance: 70mm

Find the point of intersection for the load weight of 7kg and the eccentric distance of 70mm on graph **5**, based on vertical mounting, ball bushing, 75mm stroke, and the speed of 200mm/s.
 →MGPL25-75A is selected.

5 75mm stroke or less V = 200mm/s

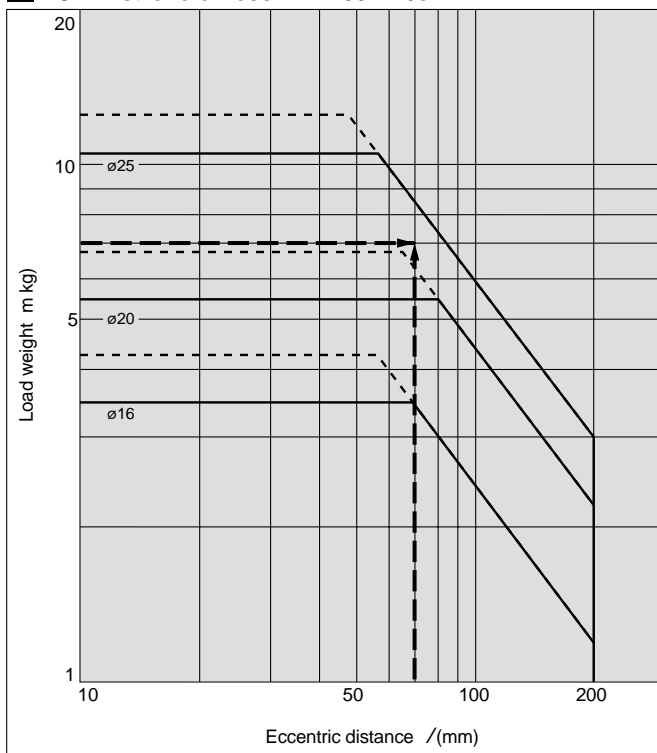

Selection Example 2 (Horizontal Mounting)

Selecting conditions
 Mounting: Horizontal
 Bearing type: Slide bearing
 Distance between plate and load center of gravity: 40mm
 Maximum speed: 300mm/s
 Load weight: 8kg
 Stroke: 100mm

Find the point of intersection for the load weight of 8kg and stroke of 100mm on graph **17**, based on horizontal mounting, slide bearing, the distance of 40mm between the plate and load center of gravity, and the speed of 300mm/s.
 →MGPM32-100A is selected.

17 l = 50mm V = 400mm/s

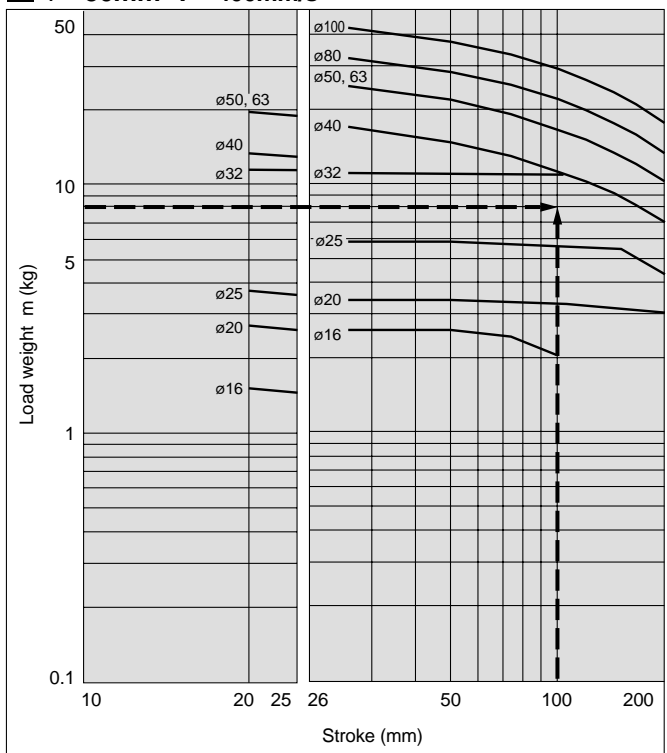

Series MGP

Vertical Mounting **Slide Bearing**

— Operating pressure: 0.4MPa
 - - - - - Operating pressure: 0.5MPa or more

MGPM16 to 100

1 25mm stroke V = 200mm/s

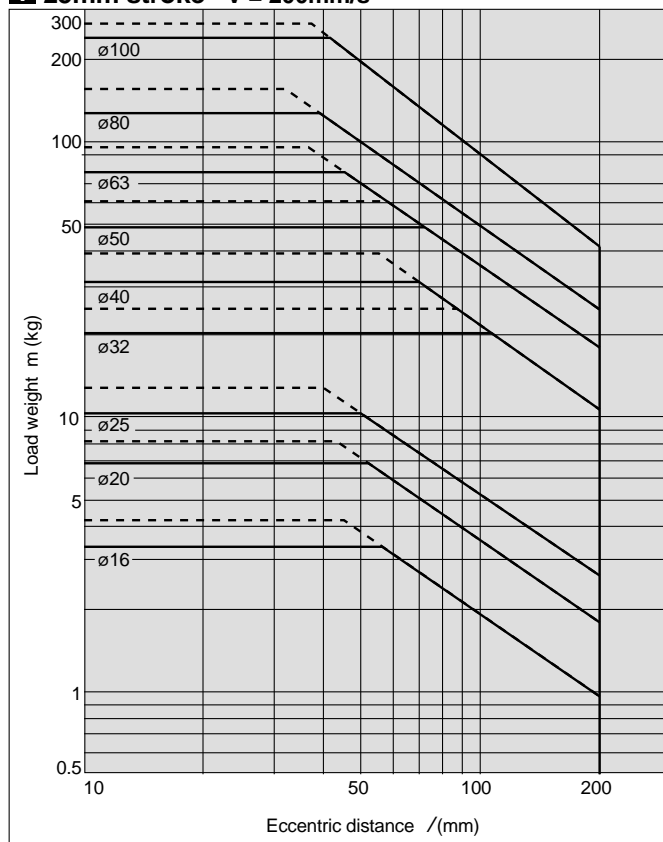

2 Over 25mm stroke V = 200mm/s

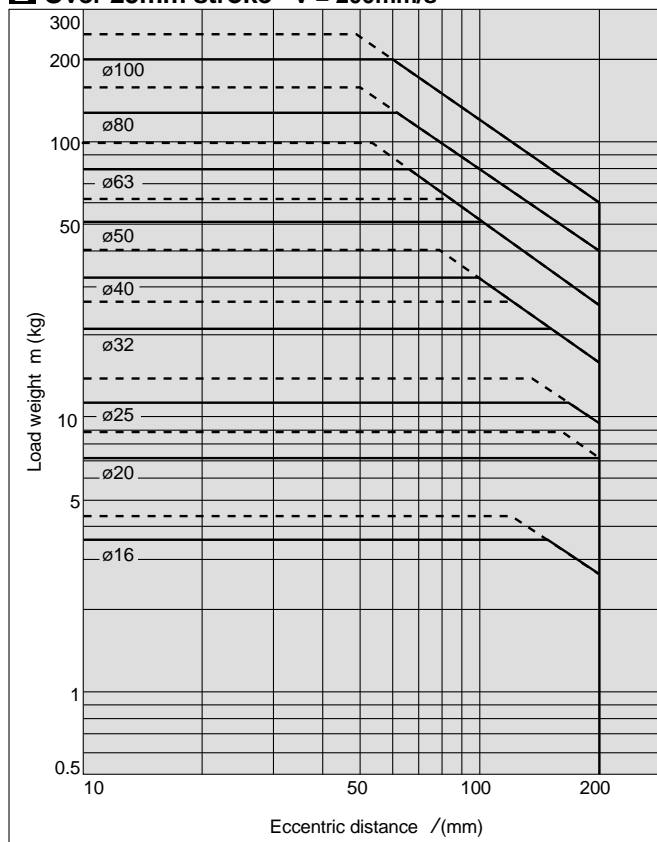

3 25mm stroke V = 400mm/s

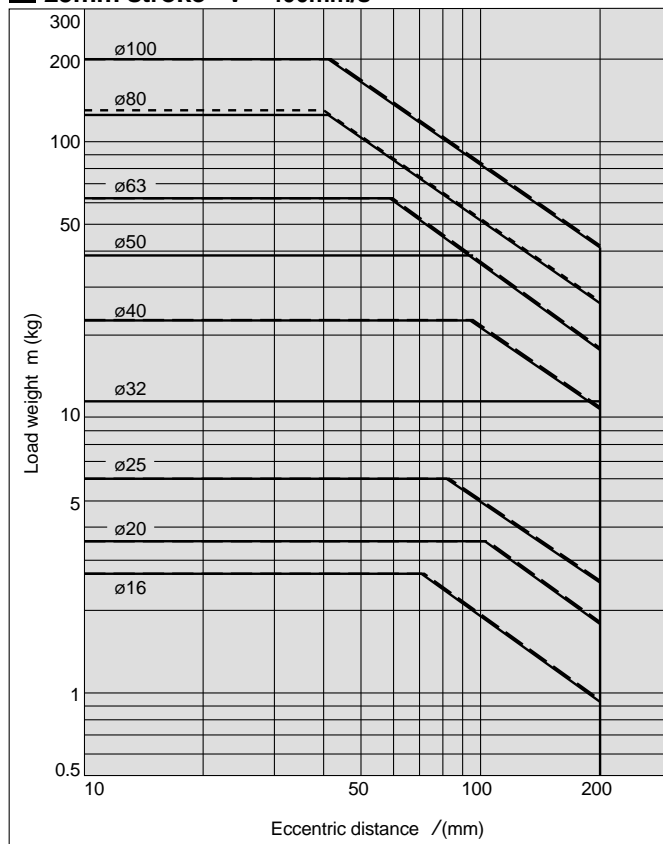

4 Over 25mm stroke V = 400mm/s

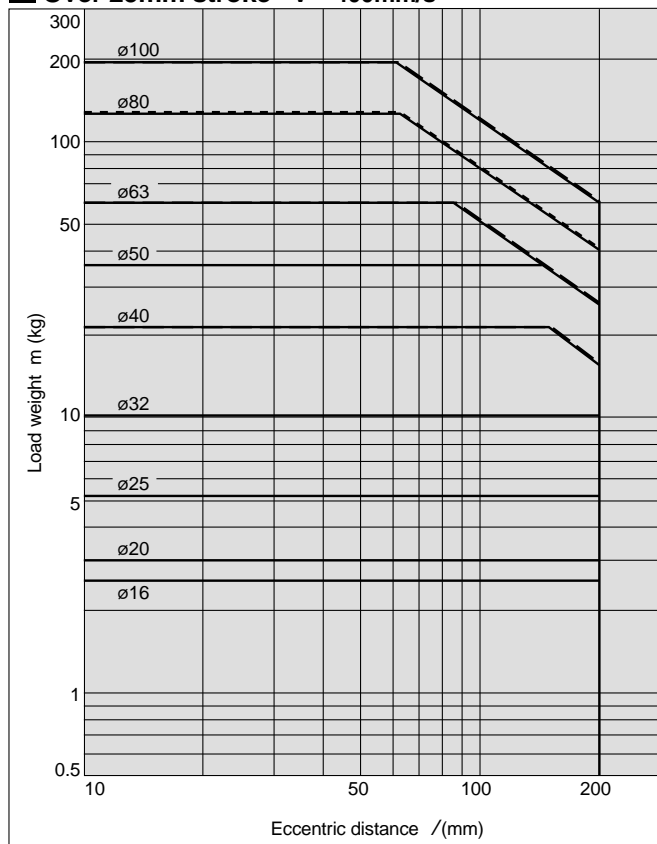

Vertical Mounting **Ball Bushing**

— Operating pressure: 0.4MPa
- - - - - Operating pressure: 0.5MPa or more

MGPL16 to 25

5 75mm stroke or less V = 200mm/s

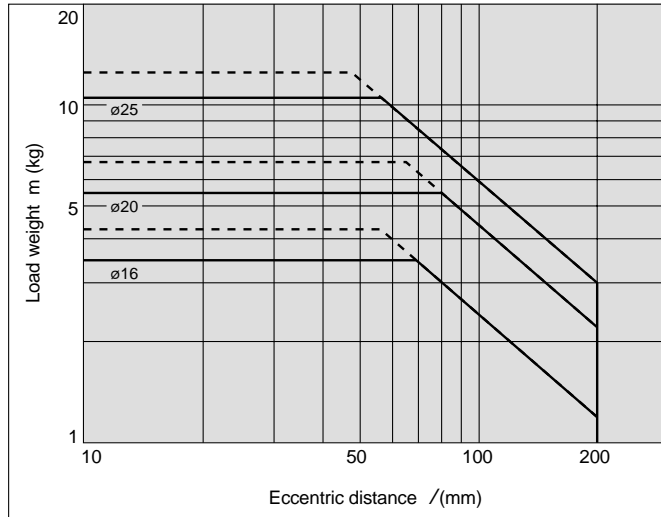

6 Over 75mm stroke V = 200mm/s

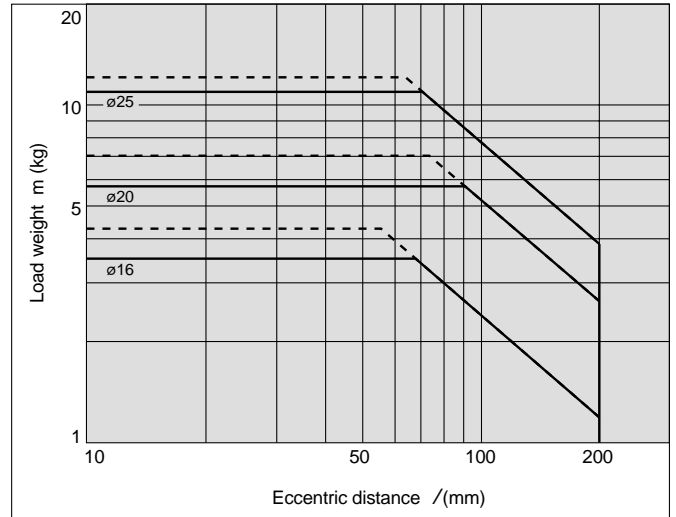

MGPL32 to 63

7 25mm stroke V = 200mm/s

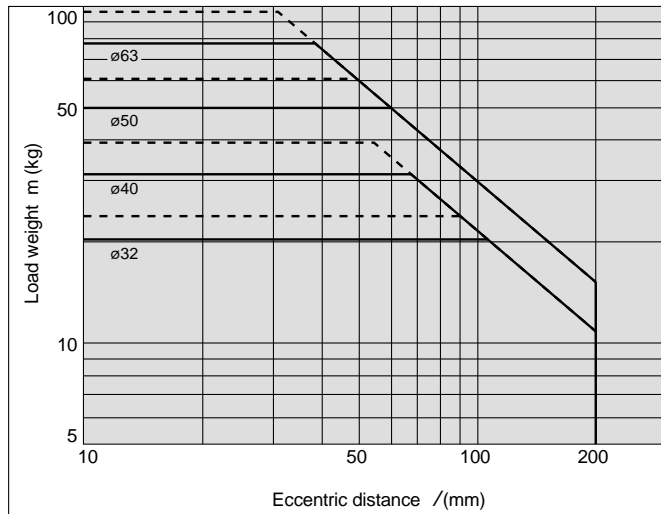

8 Over 25mm stroke V = 200mm/s

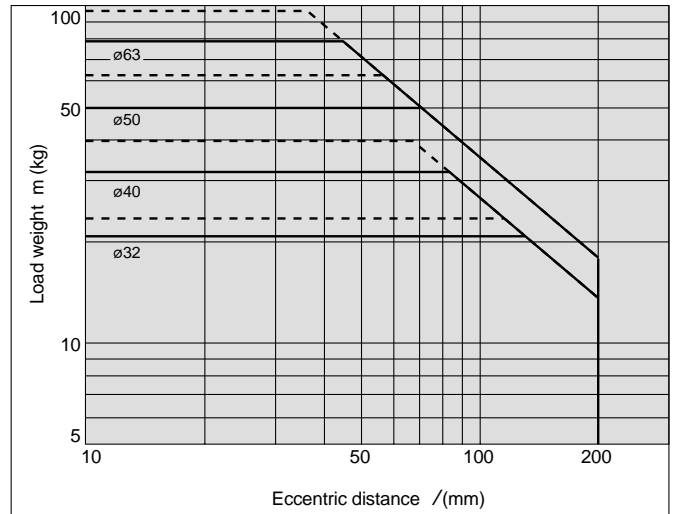

MGPL80, 100

9 V = 200mm/s

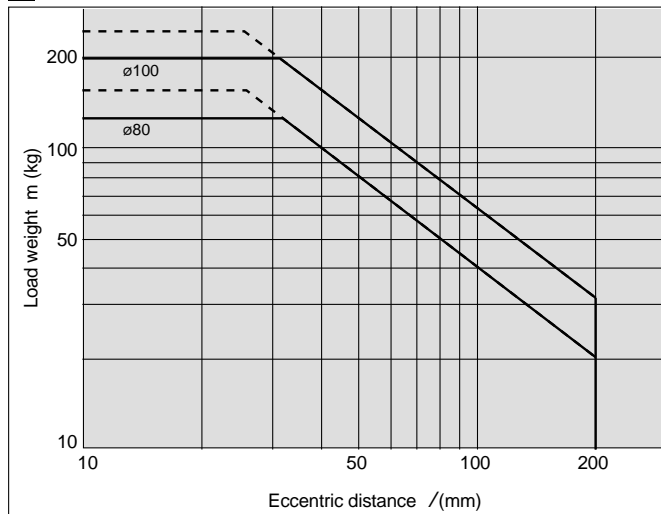

Standard Type
MGP

With Air Cushion
MGP

With End Lock
MGP

Heavy Duty
Guide Rod Type
MGPS

Order Made
Specifications

Auto Switches

Precautions

Series MGP

Vertical Mounting **Ball Bushing**

Operating pressure: 0.4MPa

MGPL16 to 25

10 75mm stroke or less V = 400mm/s

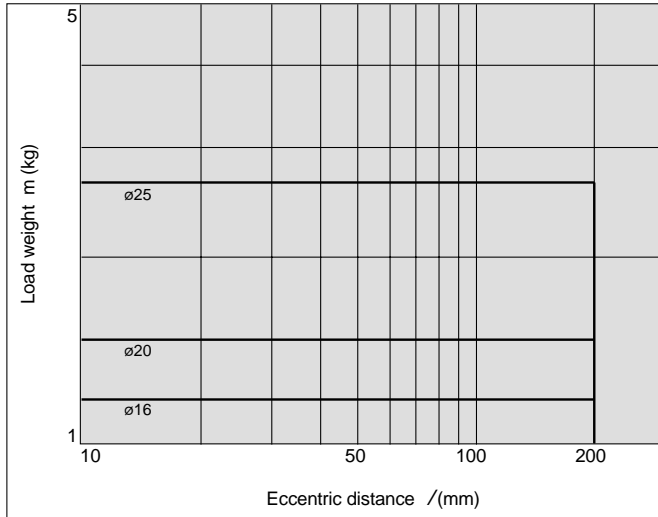

11 Over 75mm stroke V = 400mm/s

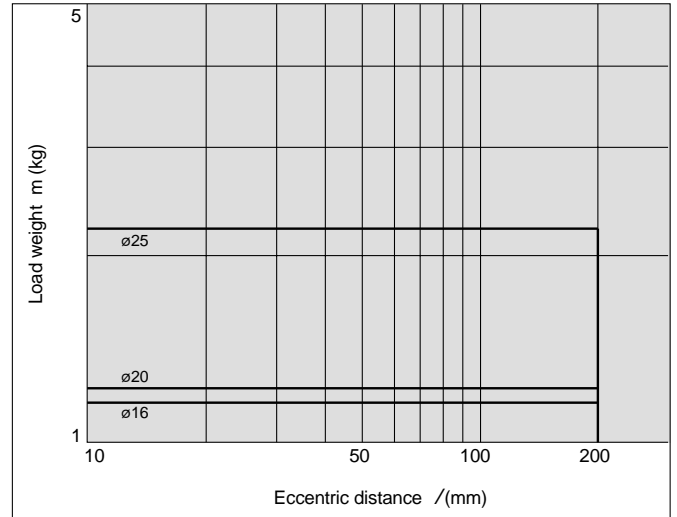

MGPL32 to 63

12 25mm stroke V = 400mm/s

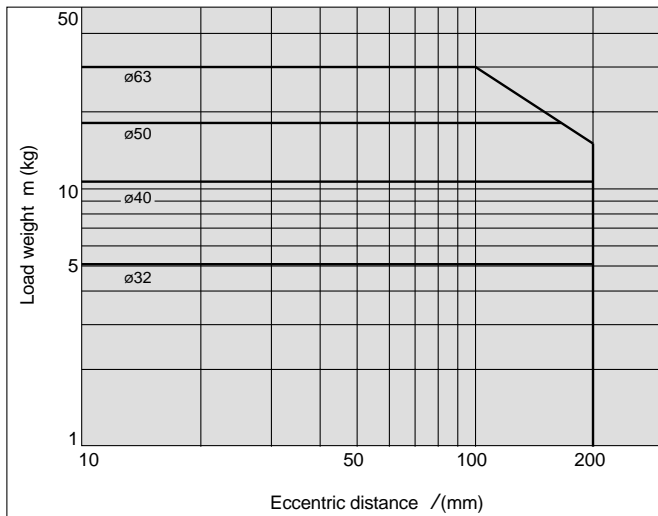

13 Over 25mm stroke V = 400mm/s

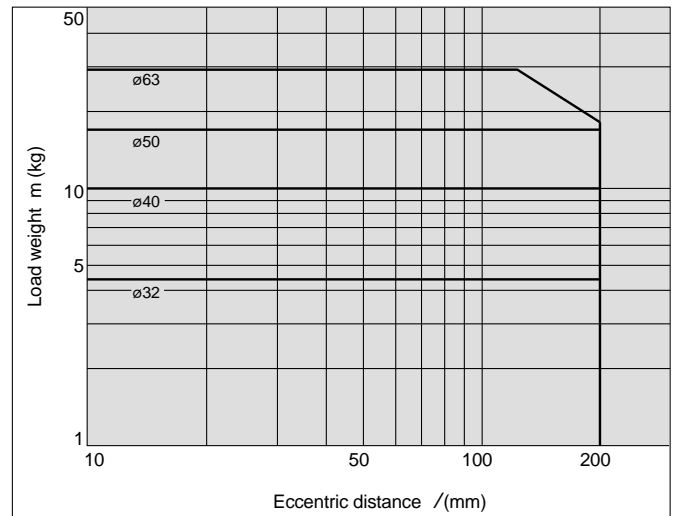

MGPL80, 100

14 V = 400mm/s

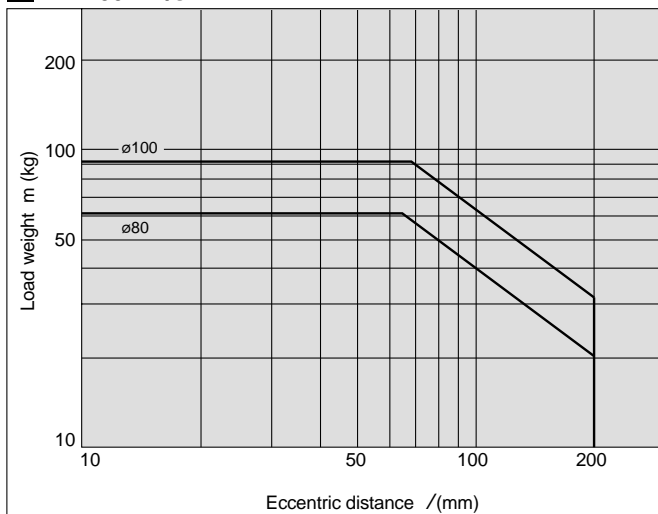

Horizontal Mounting Slide Bearing

MGPM16 to 100

15 $L = 50\text{mm}$ $V = 200\text{mm/s}$

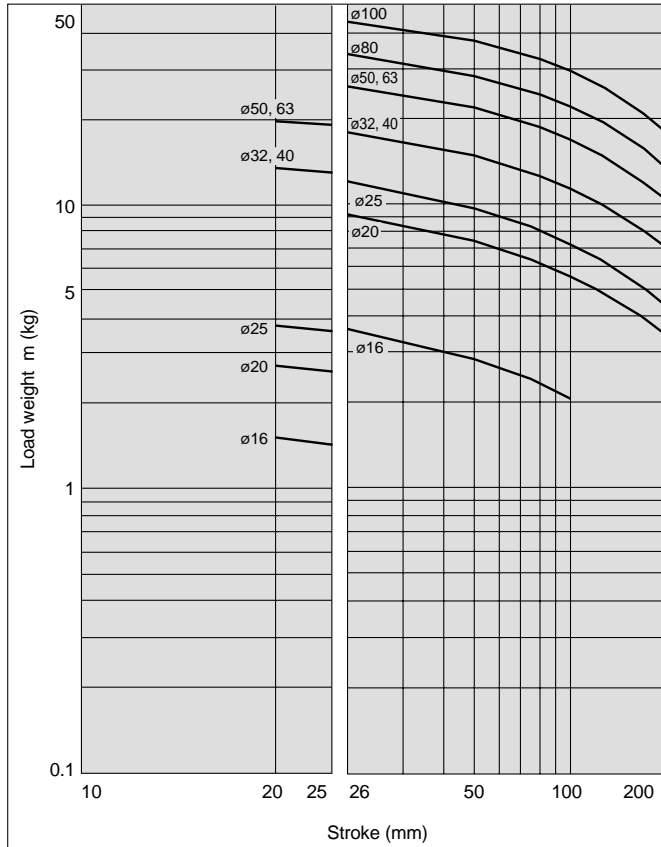

16 $L = 100\text{mm}$ $V = 200\text{mm/s}$

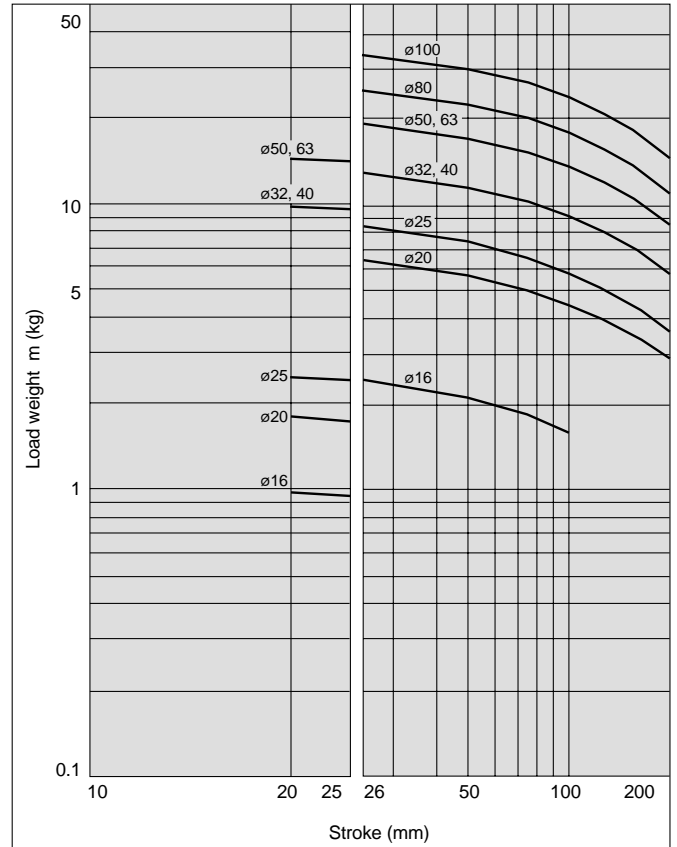

17 $L = 50\text{mm}$ $V = 400\text{mm/s}$

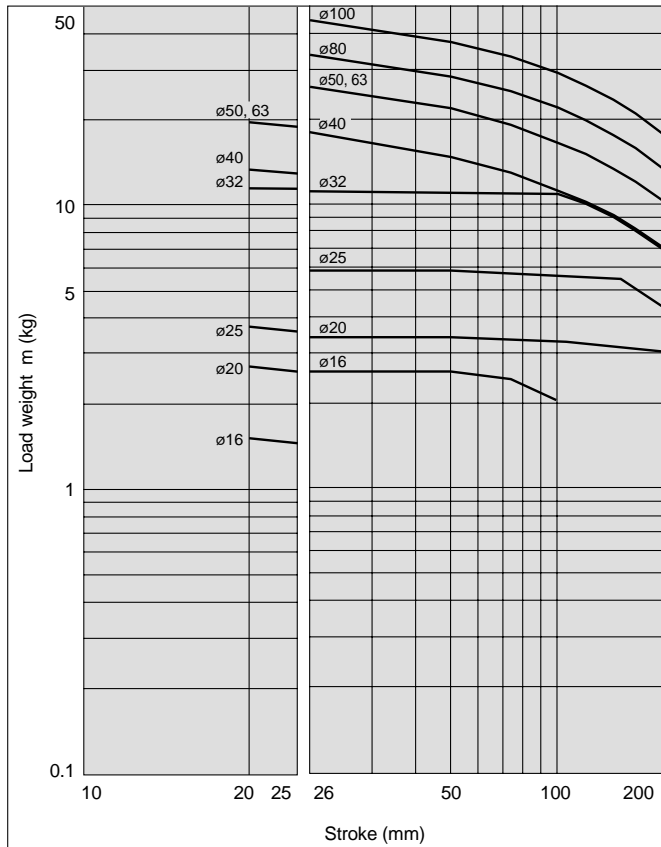

18 $L = 100\text{mm}$ $V = 400\text{mm/s}$

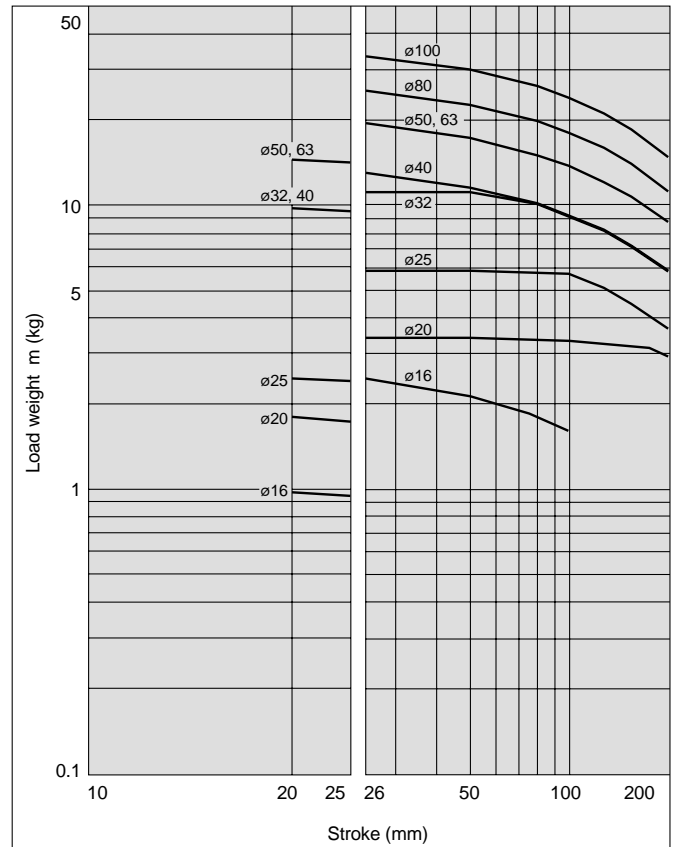

Standard Type
MGP

With Air Cushion
MGP

With End Lock
MGP

Heavy Duty
Guide Rod Type
MGPS

Order Made
Specifications

Auto Switches

Precautions

Series MGP

Horizontal Mounting **Ball Bushing**

19 $\varnothing = 50\text{mm}$ $V = 200\text{m/s}$

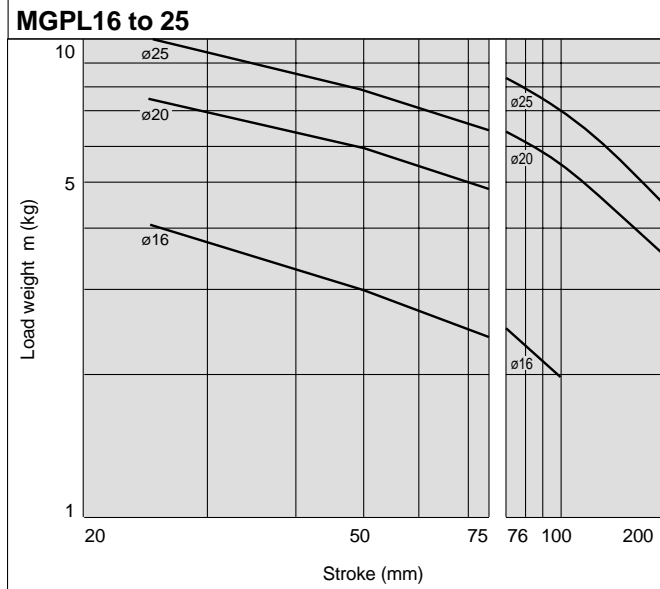

20 $\varnothing = 100\text{mm}$ $V = 200\text{m/s}$

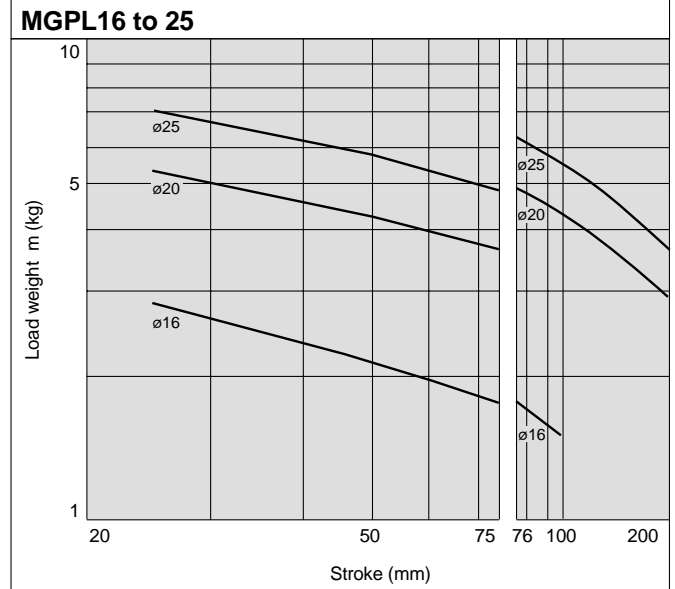

MGPL32 to 63

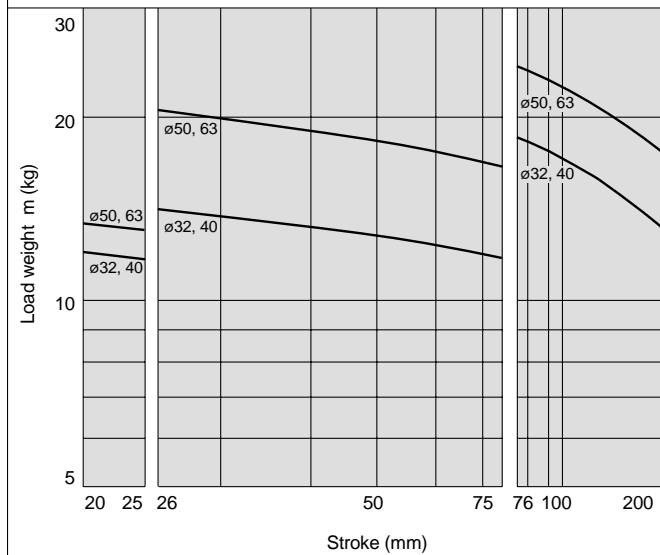

MGPL32 to 63

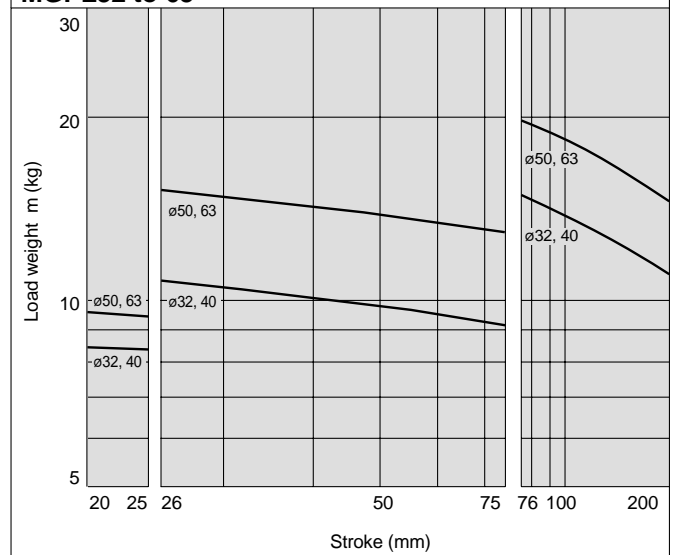

MGPL80, 100

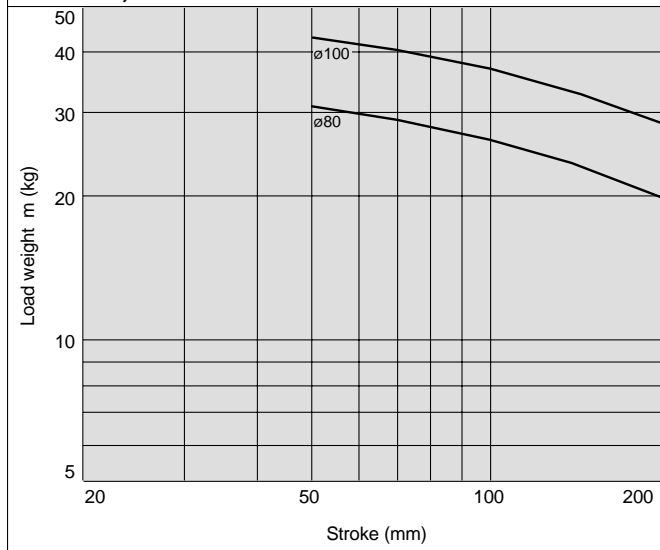

MGPL80, 100

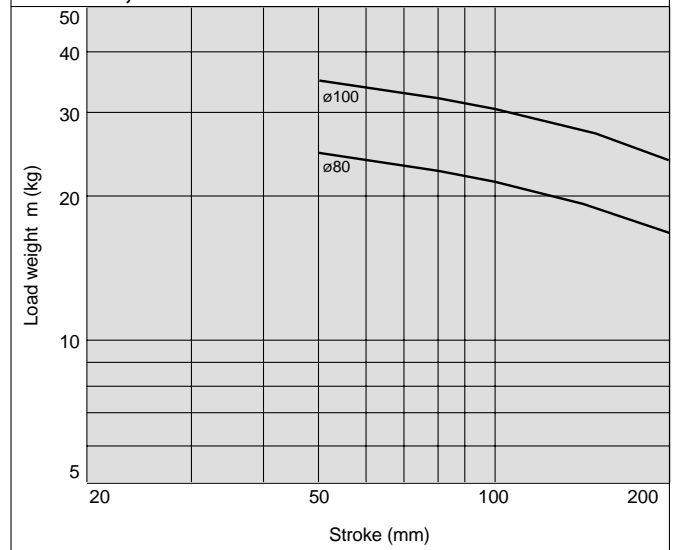

Horizontal Mounting **Ball Bushing**

21 $\varnothing = 50\text{mm}$ $V = 400\text{m/s}$

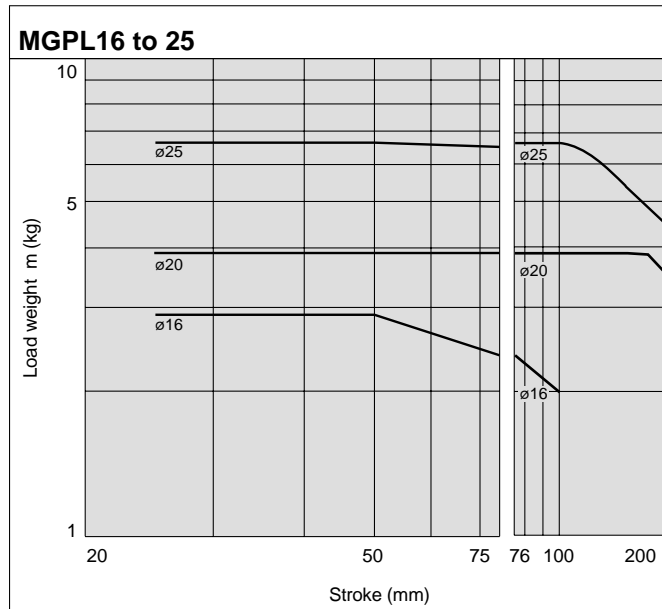

22 $\varnothing = 100\text{mm}$ $V = 400\text{m/s}$

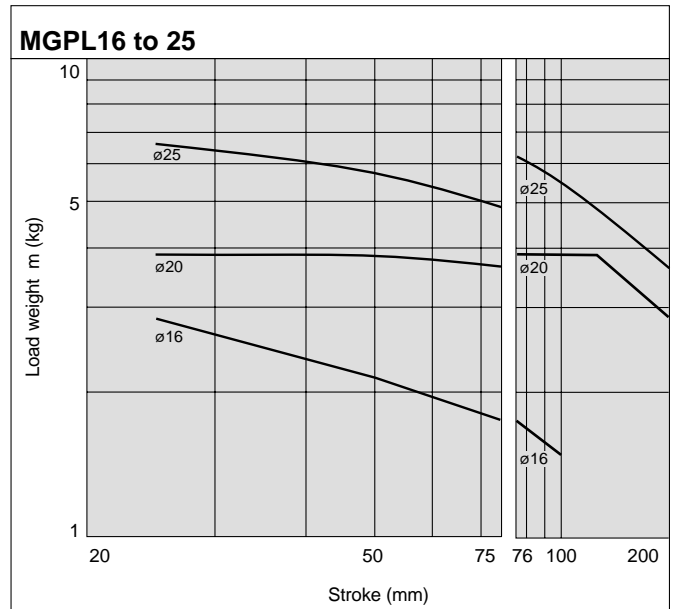

MGPL32 to 63

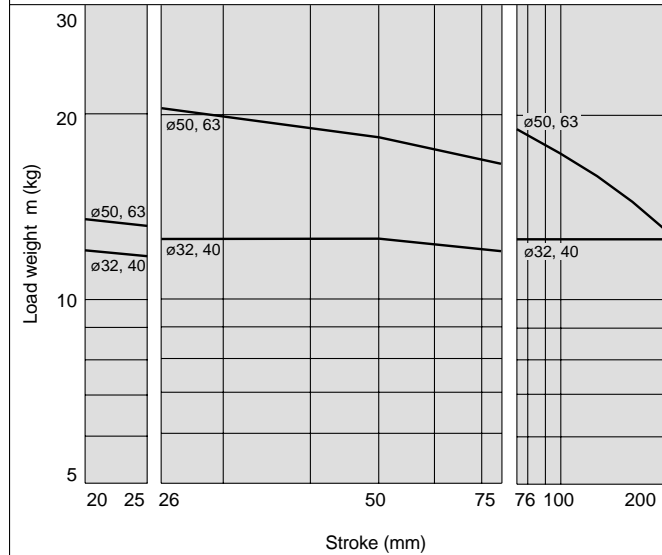

MGPL32 to 63

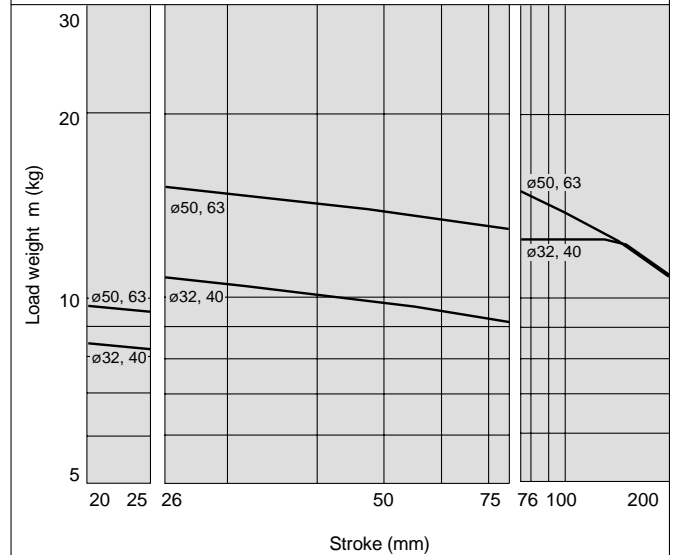

MGPL80, 100

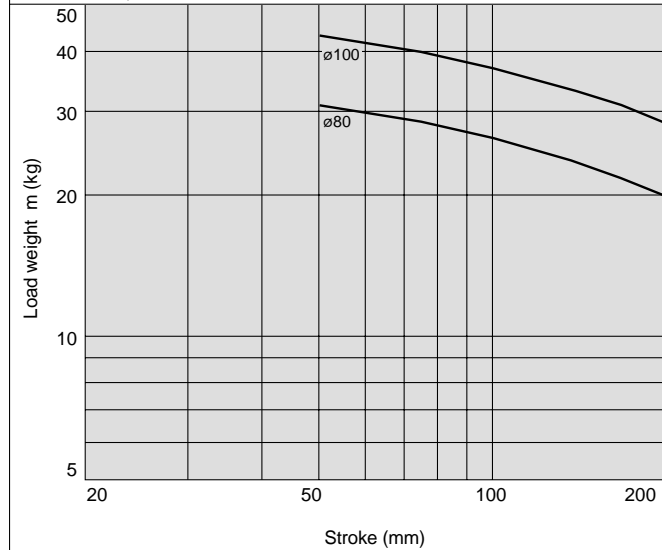

MGPL80, 100

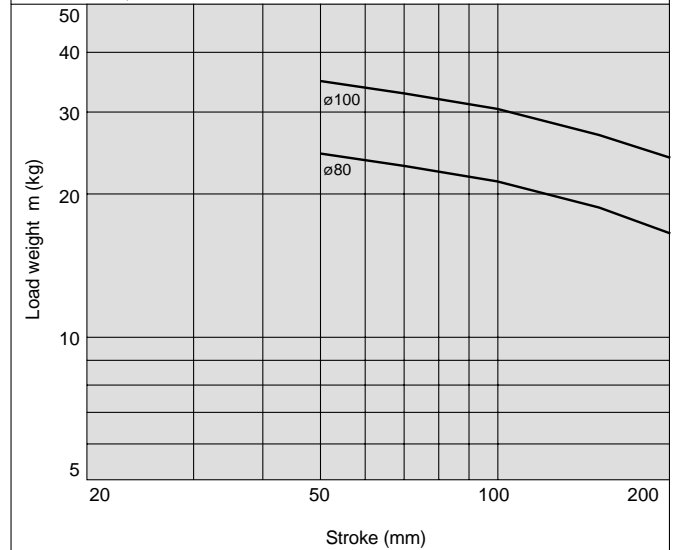

Standard Type
MGP

With Air Cushion
MGP

With End Lock
MGP

Heavy Duty
Guide Rod Type
MGPS

Order Made
Specifications

Auto Switches

Precautions

Series MGP

Operating Range when Used as Stopper

Bore Sizes $\varnothing 16$ to 25/MGPM16 to 25 (Slide bearing)

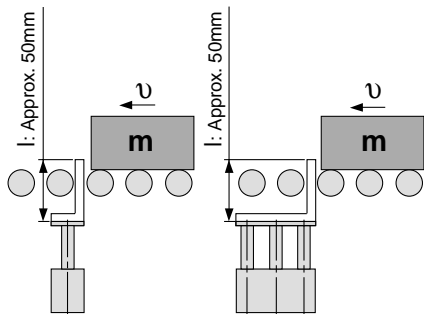

* When selecting a model with a longer l /dimension, be sure to choose a bore size which is sufficiently large.

⚠ Caution

Handling precautions

Note 1) When using as a stopper, select a model with a stroke of 25mm or less.

Note 2) Model MGPL (ball bushing) cannot be used as a stopper.

MGPM16 to 25 (Slide bearing)

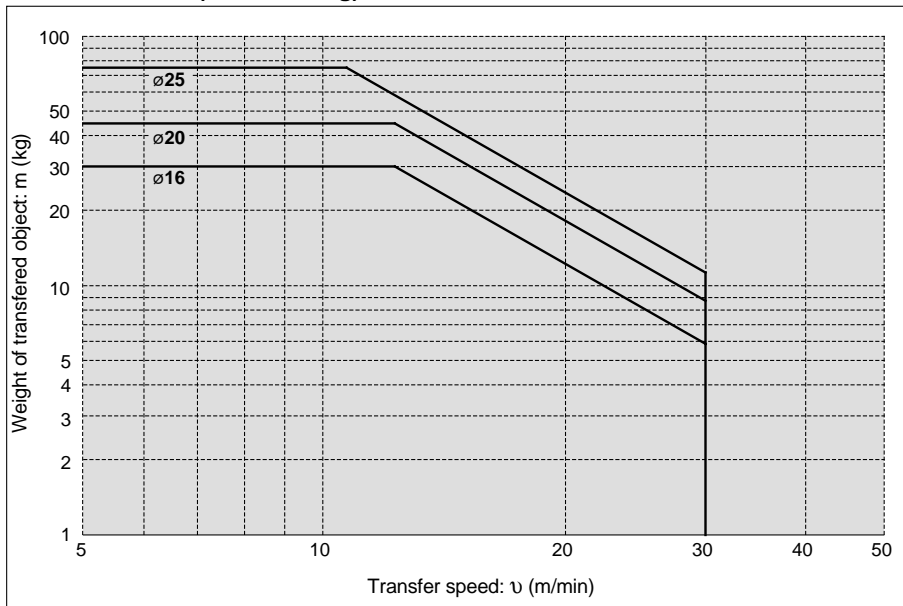

Bore Sizes $\varnothing 32$ to 100/MGPM32 to 100 (Slide bearing)

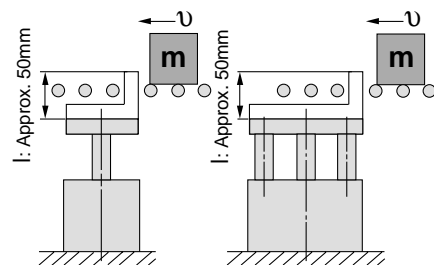

* When selecting a model with a longer l /dimension, be sure to choose a bore size which is sufficiently large.

⚠ Caution

Handling precautions

Note 1) When using as a stopper, select a model with a stroke of 50mm or less.

Note 2) Model MGPL (ball bushing) cannot be used as a stopper.

MGPM32 to 100 (Slide bearing)

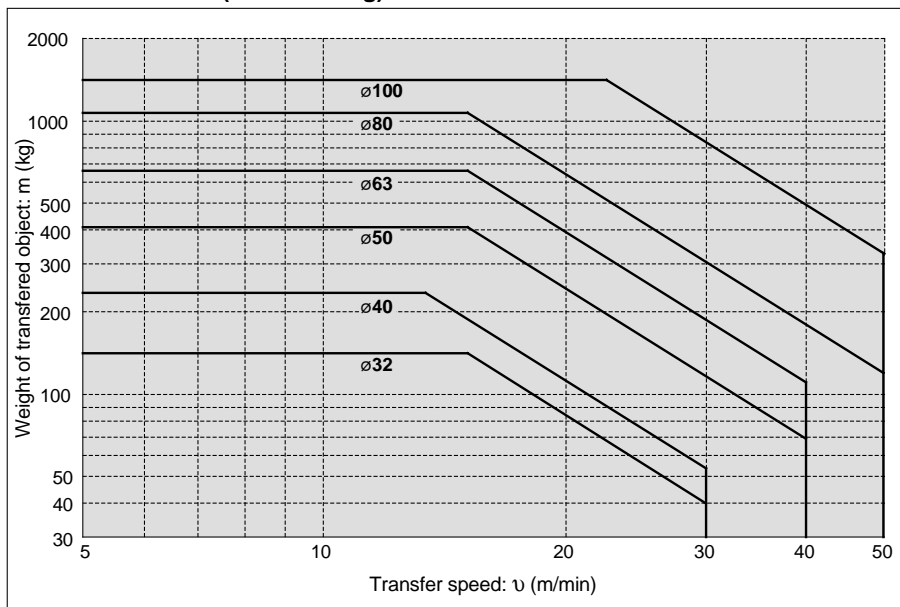

Copper-free Series (Applicable to CRT Manufacturing Process)

To prevent the influence of copper ions or halogen ions during CRT manufacturing processes, copper and fluorine materials are not used as component parts.

Specifications

Applicable series	MGPM	MGPL
Bearing type	Slide bearing	Ball bushing
Bore size (mm)	16, 20, 25, 32, 40, 50, 63, 80, 100	

* Specifications and dimensions other than above are identical to the standard basic type.

How to Order

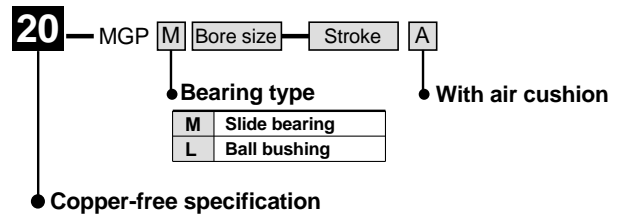

Auto Switches/Proper Mounting Position for Stroke End Detection

For D-P5DW (* Cannot be mounted on bore sizes $\phi 32$ or less.)

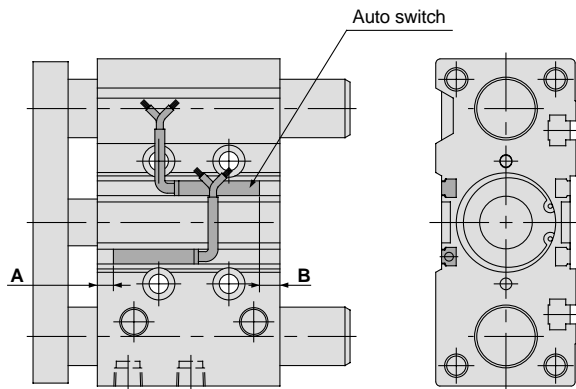

Proper mounting position (mm)

Bore size (mm)	A	B
16	17.5	15.5
20	26	11
25	23	14.5
32	16	21.5

Bore size (mm)	(mm)	
Bore size (mm)	A	B
40	26	18
50	27.5	16.5
63	28	21
80	25	31.5
100	28.5	37.5

Note 1) Minimum mountable strokes for auto switch are 10mm or more for two switches, and 5mm or more for one switch.

$\phi 40$ to $\phi 63$

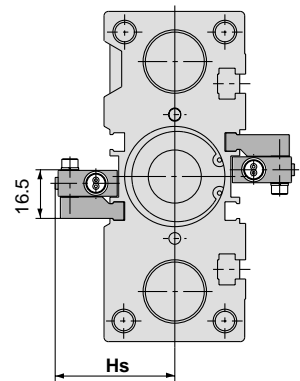
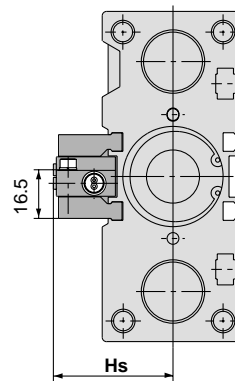

For 25mm stroke

* For bore sizes $\phi 40$ through 63 with two switches, one switch is mounted on each side.

$\phi 80, \phi 100$

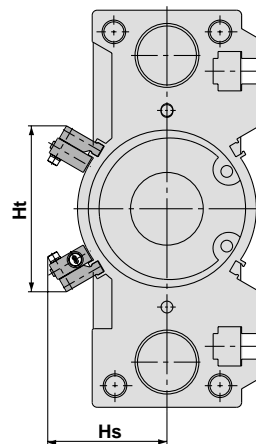

Bore size (mm)	Hs	Ht
40	44.5	—
50	50	—
63	57	—
80	60.7	84.4
100	70.8	96.1

* Minimum mountable strokes for auto switch are 10mm or more for two switches, and 5mm or more for one switch.

Auto Switch Mounting

⚠ Caution

Auto switch mounting tool

- When tightening the auto switch mounting screw (included with auto switch), use a watchmakers screw driver with a handle about 5 to 6mm in diameter.

Tightening torque

- Tighten with a torque of 0.05 to 0.1N·m. As a rule, it should be turned about 90° past the point at which tightening can be felt.

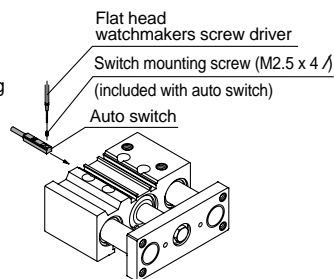

For D-P5DW

⚠ Caution

Auto switch mounting tool

- When tightening hexagon socket head cap screws of the auto switch, use hexagon wrench key 2 or 2.5 with the appropriate screws.

Tightening torque

- Tighten M2.5 screws with a torque of about 0.3 to 0.5N·m, and M3 screws with a torque of about 0.5 to 0.7 N·m.

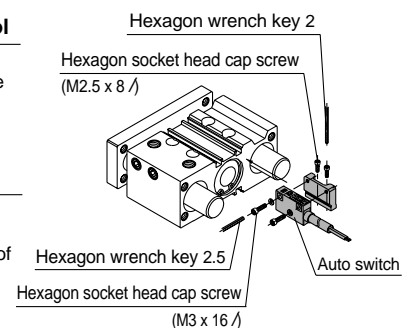

Series MGP

Construction (With Air Cushion)

Series MGPM

MGPM16 to 25

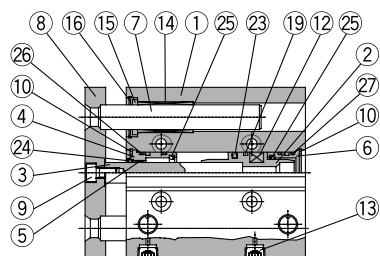

25mm stroke

Cushion valve section

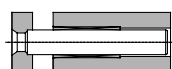

ø16: 25mm stroke



ø16: 50mm stroke or larger



ø20, ø25: 50mm stroke or larger

Series MGPL

MGPL16 to 25

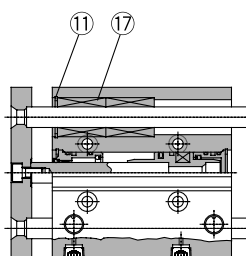

25mm stroke



ø20, ø25: 75mm stroke or less



ø20, ø25: 100mm stroke or larger

MGPM32 to 100

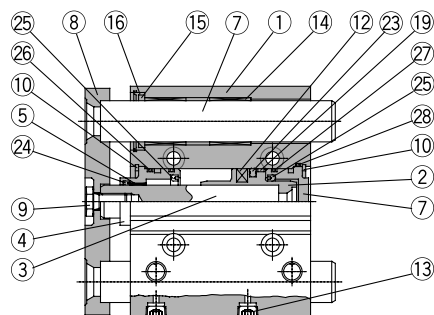

25mm stroke

Cushion valve section



50mm stroke or larger

MGPL32 to 100

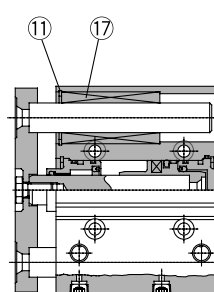

25mm stroke

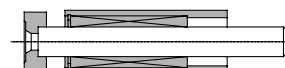

ø32 to ø63: 50, 75mm stroke
ø80, ø100: 50mm stroke or larger



ø32 to ø63: 100mm stroke or larger

Parts list

No.	Description	Material	Note
1	Body	Aluminum alloy	Hard anodized
2	Piston	Aluminum alloy	Chromated
3	Piston rod	Stainless steel	ø16 to ø25
		Carbon steel	ø32 to ø100 Hard chrome plated
4	Collar	Aluminum alloy	ø16 to ø63 Clear anodized ø80, ø100 Coated
5	Bushing	Lead bronze casting	
6	Head cover	Aluminum alloy	ø16 to ø25 Clear anodized
			ø32 to ø100 Coated
7	Guide rod	Carbon steel	Hard chrome plated
8	Plate	Carbon steel	Nickel plated
9	Plate mounting bolt	Carbon steel	Nickel plated
10	Snap ring	Carbon tool steel	Phosphate coated
11	Snap ring	Carbon tool steel	Phosphate coated
12	Magnet	Synthetic rubber	
13	Plug (M-5P)	Brass	ø16 Nickel plated
	Hexagon socket head taper plug	Carbon steel	ø20 to ø100 Nickel plated
14	Slide bearing	Lead bronze casting	
15	Felt	Felt	
16	Holder	Resin	
17	Ball bushing		

Parts list

No.	Description	Material	Note
18	Spacer	Aluminum alloy	
19	Wear ring	Resin	
20	Cushion valve	Steel	
21	Gasket	NBR	
22	Snap ring	Carbon tool steel	Except ø16
23*	Piston seal	NBR	
24*	Rod seal	NBR	
25*	Cushion seal	Urethane	
26*	Gasket A	NBR	
27*	Gasket B	NBR	
28*	Gasket C	NBR	

Replacement parts: Seal kits

Bore size (mm)	Kit no.	Contents	Bore size (mm)	Kit no.	Contents
16	MGP16-A-PS	Kits include items 23, 24, 25, 26, 27, 28 from the table above.	50	MGP50-A-PS	Kits include items 23, 24, 25, 26, 27, 28 from the table above.
20	MGP20-A-PS		63	MGP63-A-PS	
25	MGP25-A-PS		80	MGP80-A-PS	
32	MGP32-A-PS		100	MGP100-A-PS	
40	MGP40-A-PS				

* Seal kits are sets consisting of items 23 through 28 above, and can be ordered using the kit number for each bore size.

∅16 to ∅25/MGPM, MGPL (With Air Cushion)

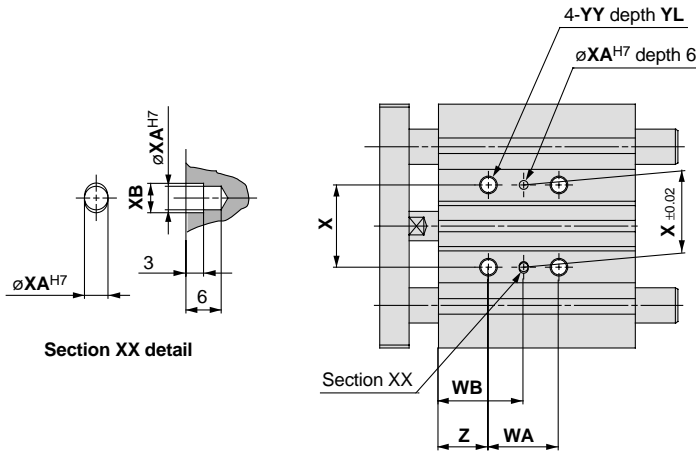

T-slot dimensions

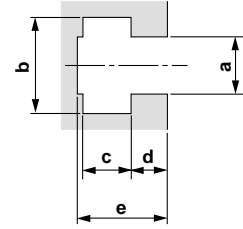

Bore size (mm)	a	b	c	d	e
16	4.4	7.4	3.7	2.5	6.7
20	5.4	8.4	4.5	2.8	7.8
25	5.4	8.4	4.5	3	8.2

(mm)

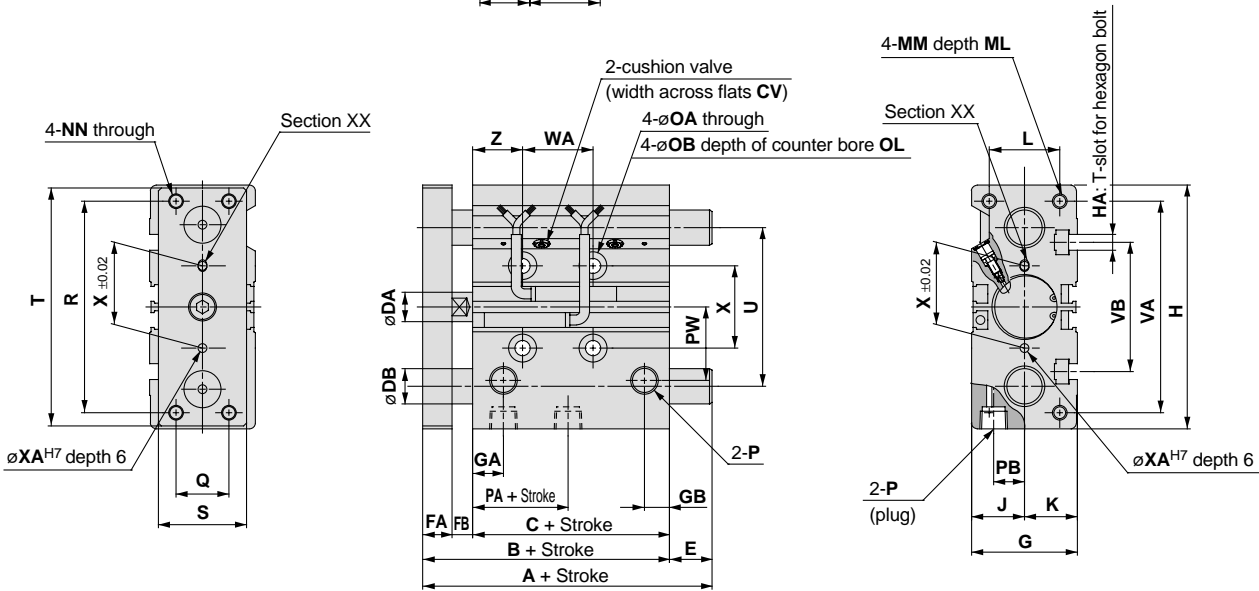

Note 1) Refer to "Manufacture of Intermediate Strokes" on page 19 for intermediate strokes.
Note 2) When adjusting the ∅16 cushion valve, use a 3mm flat head watchmakers screw driver.

MGPM, MGPL Common dimensions

Bore size (mm)	Standard stroke (mm)	B	C	CV	DA	FA	FB	G	GA	GB	H	HA	J	K	L	MM	ML	NN	OA	OB	OL	P	PA	PB	PW	Q	Stroke											
																											75st or less	100 to 175st	200st	75st or less	100 to 175st	200st	X	XA	XB	YY	YL	Z
16	25, 50, 75, 100	71	58	—	8	8	5	30	11	8	64	M4	15	15	22	M5 x 0.8	12	M5 x 0.8	4.3	8	4.5	M5 x 0.8	40	10	19	16	44	110	—	27	60	—	24	3	3.5	M5 x 0.8	10	5
20	25, 50, 75, 100,	78	62	1.5	10	10	6	36	10.5	8.5	83	M5	18	18	24	M5 x 0.8	13	M5 x 0.8	5.6	9.5	5.5	Rc 1/8	37.5	10.5	25	18	44	120	200	39	77	117	28	3	3.5	M6 x 1.0	12	17
25	125, 150, 175, 200	78.5	62.5	1.5	12	10	6	42	11.5	9	93	M5	21	21	30	M6 x 1.0	15	M6 x 1.0	5.6	9.5	5.5	Rc 1/8	37.5	13.5	28.5	26	44	120	200	39	77	117	34	4	4.5	M6 x 1.0	12	17

MGPM (slide bearing)/Dimensions A, DB, E (mm)

Bore size (mm)	A			DB	E		
	25st	50st	75st or more		25st	50st	75st or more
16	71	89.5	71	10	0	18.5	0
20	78	86.5	84.5	12	0	8.5	6.5
25	78.5	87	85	16	0	8.5	6.5

MGPL (ball bushing)/Dimensions A, DB, E (mm)

Bore size (mm)	A				DB	E			
	25st	50, 75st	100st	125st or more		25st	50, 75st	100st	125st or more
16	80	71	71	—	8	9	0	0	—
20	95	80	99	104	10	17	2	21	26
25	100.5	85.5	99.5	104.5	13	22	7	26	26

Standard Type
MGP

With Air Cushion
MGP

With End Lock
MGP

Heavy Duty
Guide Rod Type
MGPS

Order Made
Specifications

Auto Switches

Precautions

Series MGP

∅32 to ∅63/MGPM, MGPL (With Air Cushion)

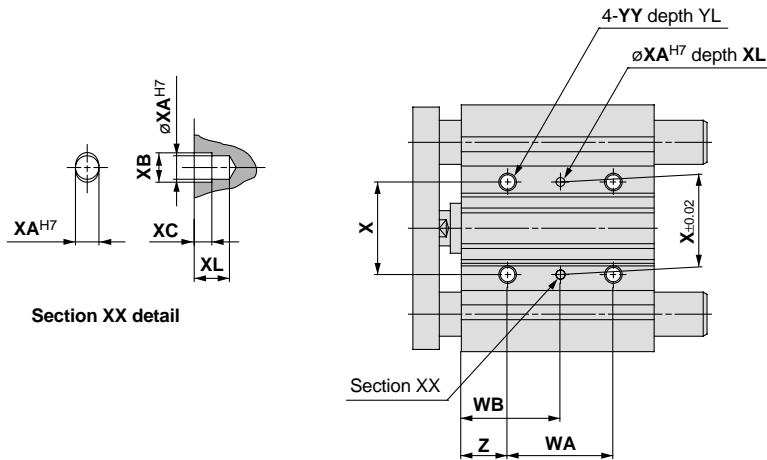

T-slot dimensions

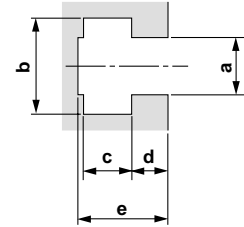

Bore size (mm)	a	b	c	d	e
32	6.5	10.5	5.5	3.5	9.5
40	6.5	10.5	5.5	4	11
50	8.5	13.5	7.5	4.5	13.5
63	11	17.8	10	7	18.5

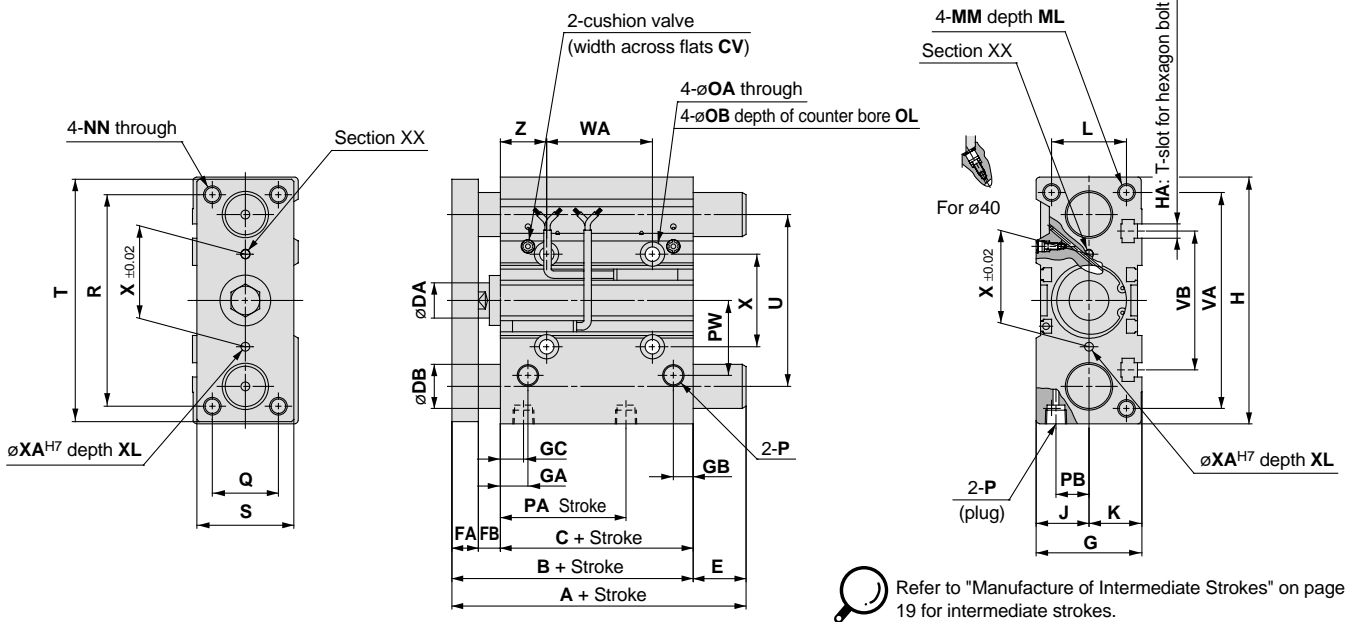

Refer to "Manufacture of Intermediate Strokes" on page 19 for intermediate strokes.

MGPM, MGPL Common dimensions

Bore size (mm)	Standard stroke (mm)	B	C	CV	DA	FA	FB	G	GA	GB	GC	H	HA	J	K	L	MM	ML	NN	OA	OB	OL	P	PA	PB	PW	Q
32	25, 50, 75,	84.5	62.5	1.5	16	12	10	48	12.5	9	12.5	112	M6	24	24	34	M8 x 1.25	20	M8 x 1.25	6.6	11	7.5	Rc 1/8	32	15	34	30
40	100, 125,	91	69	1.5	16	12	10	54	14	10	14	120	M6	27	27	40	M8 x 1.25	20	M8 x 1.25	6.6	11	7.5	Rc 1/8	38	18	38	30
50	150, 175, 200	97	69	2.5	20	16	12	64	14	11	12	148	M8	32	32	46	M10 x 1.5	22	M10 x 1.5	8.6	14	9	Rc 1/4	34	21.5	47	40
63		102	74	2.5	20	16	12	78	16.5	13.5	16.5	162	M10	39	39	58	M10 x 1.5	22	M10 x 1.5	8.6	14	9	Rc 1/4	39	28	55	50

Bore size (mm)	Standard stroke (mm)	R	S	T	U	VA	VB	WA			WB			X	XA	XB	XC	XL	YY	YL	Z
								25, 50, 75st	100 to 175st	200st	25, 50, 75st	100 to 175st	200st								
32	25, 50, 75,	96	44	110	78	98	63	48	124	200	45	83	121	42	4	4.5	3	6	M8 x 1.25	16	21
40	100, 125,	104	44	118	86	106	72	48	124	200	46	84	122	50	4	4.5	3	6	M8 x 1.25	16	22
50	150, 175, 200	130	60	146	110	130	92	48	124	200	48	86	124	66	5	6	4	8	M10 x 1.5	20	24
63		130	70	158	124	142	110	52	128	200	50	88	124	80	5	6	4	8	M10 x 1.5	20	24

MGPM (slide bearing)/Dimensions A, DB, E (mm)

Bore size (mm)	A			DB	E		
	25st	50st	75st or more		25st	50st	75st or more
32	97	127	102	20	12.5	42.5	17.5
40	97	127	102	20	6	36	11
50	106.5	131.5	118	25	9.5	34.5	21
63	106.5	131.5	118	25	4.5	29.5	16

MGPL (ball bushing)/Dimensions A, DB, E (mm)

Bore size (mm)	A					DB	E				
	25st	50st	75st	100st	125st or more		25st	50st	75st	100st	125st or more
32	84.5	123	98	115.5	118	16	0	38.5	13.5	31	33.5
40	91	123	98	115.5	118	16	0	32	7	24.5	27
50	97	127.5	114	159	134	20	0	30.5	17	62	37
63	102	127.5	114	159	134	20	0	25.5	12	57	32

∅80, ∅100/MGPM, MGPL (With Air Cushion)

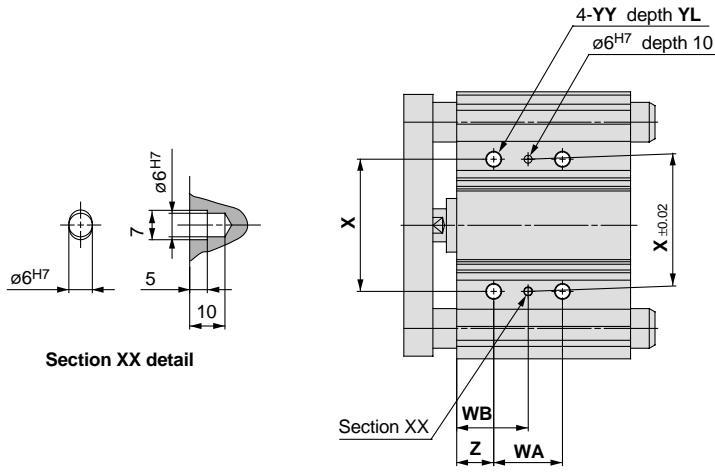

T-slot dimensions

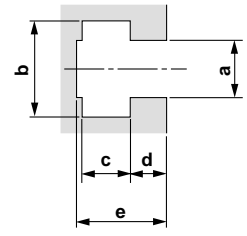

Bore size (mm)	a	b	c	d	e
80	13.3	20.3	12	8	22.5
100	15.3	23.3	13.5	10	30

(mm)

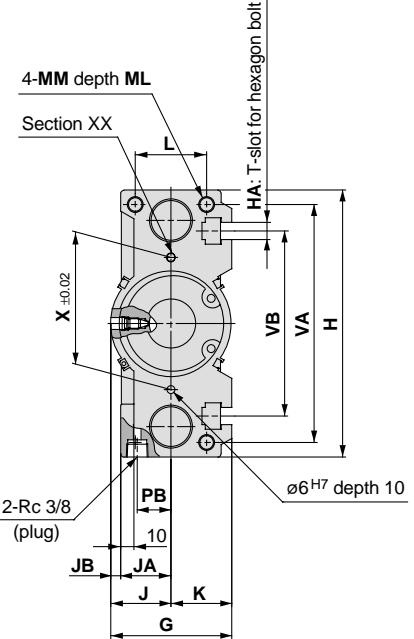
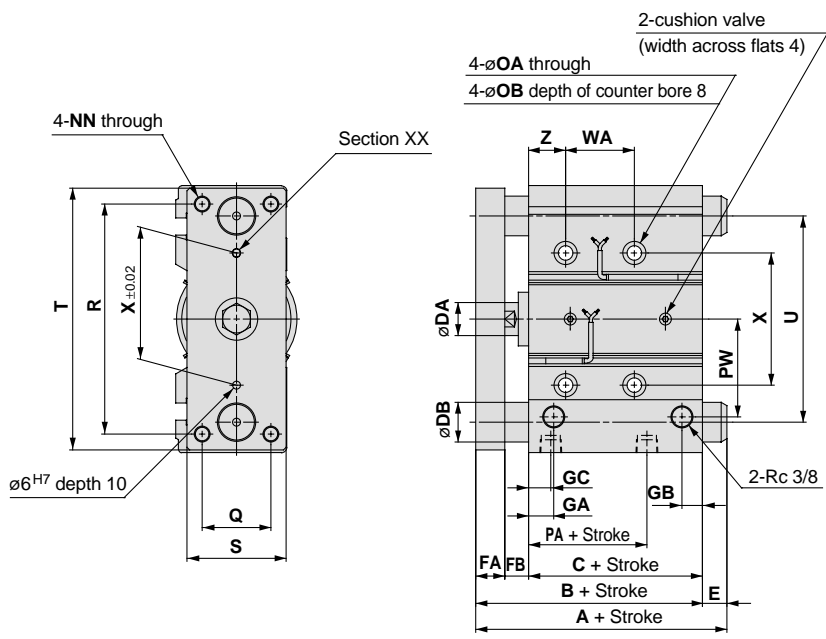

Refer to "Manufacture of Intermediate Strokes" on page 19 for intermediate strokes.

MGPM, MGPL Common dimensions

Bore size (mm)	Standard stroke (mm)	B	C	DA	FA	FB	G	GA	GB	GC	H	HA	J	JA	JB	K	L	MM	ML	NN	OA	OB	PA	PB	PW
80	50, 75, 100, 125, 150, 175, 200	121.5	81.5	25	22	18	91.5	19	15.5	14.5	202	M12	45.5	38	7.5	46	54	M12 x 1.75	25	M12 x 1.75	10.6	17.5	39.5	25.5	74
100	150, 175, 200	141	91	30	25	25	111.5	23	19	18	240	M14	55.5	45	10.5	56	62	M14 x 2.0	31	M14 x 2.0	12.5	20	42.5	32.5	89

Bore size (mm)	Standard stroke (mm)	Q	R	S	T	U	VA	VB	WA			WB			X	YY	YL	Z
									50, 75st	100 to 175st	200st	50, 75st	100 to 175st	200st				
80	50, 75, 100, 125, 150, 175, 200	52	174	75	198	156	180	140	52	128	200	54	92	128	100	M12 x 1.75	24	28
100	150, 175, 200	64	210	90	236	188	210	166	72	148	220	47	85	121	124	M14 x 2.0	28	11

MGPM (slide bearing)/Dimensions A, DB, E (mm)

Bore size (mm)	A		DB	E	
	50st	75st or more		50st	75st or more
80	167	142	30	45.5	20.5
100	187	162	36	46	21

MGPL (ball bushing)/Dimensions A, DB, E (mm)

Bore size (mm)	A		DB	E	
	50st	75st or more		50st	75st or more
80	168.5	160	25	47	38.5
100	178.5	180	30	37.5	39

Standard Type
MGP

With Air Cushion
MGP

With End Lock
MGP

Heavy Duty
Guide Rod Type
MGPS

Order Made
Specifications

Auto Switches

Precautions

Compact Guide Cylinder: With End Lock

Series *MGP*

ø20, ø25, ø32, ø40, ø50, ø63, ø80, ø100

How to Order

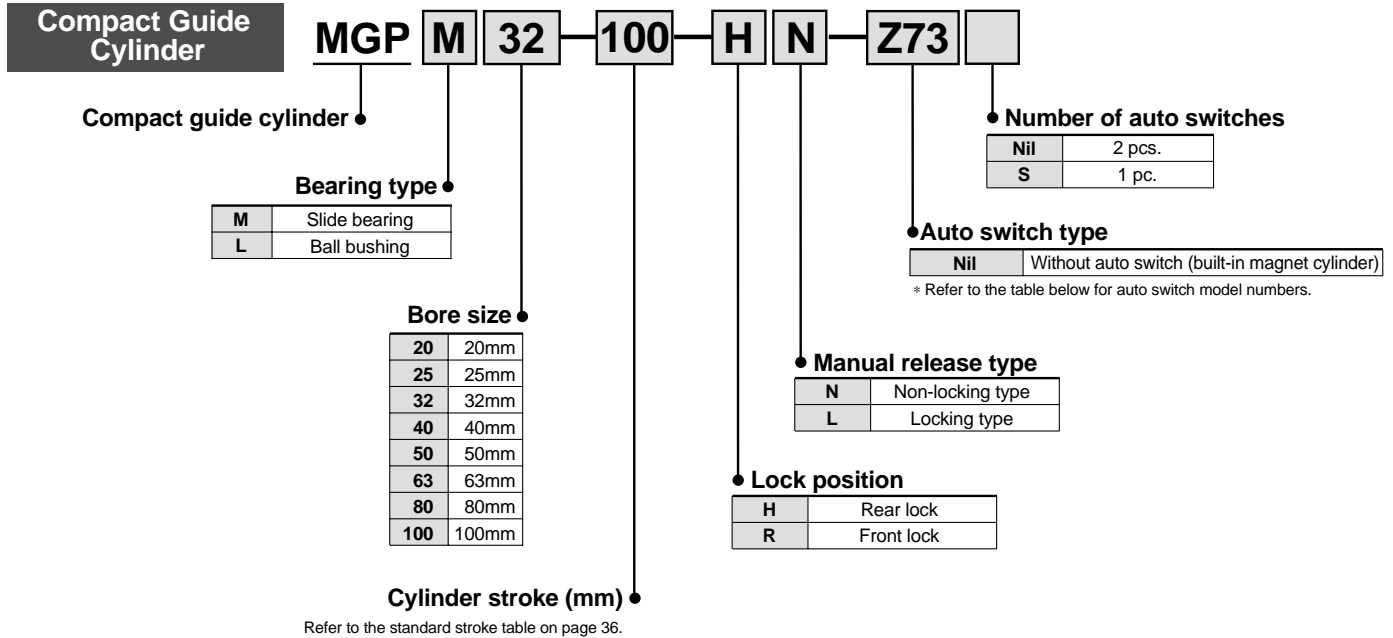

Applicable auto switches

Type	Special function	Electrical entry	Indicator light	Wiring (output)	Load voltage		Auto switch model		Lead wire length (m) ^{Note 1)}			Applicable load		Detailed specifications	
					DC	AC	Electrical entry direction	In-line	0.5 (Nil)	3 (L)	5 (Z)	IC circuit	Relay, PLC		
Reed switch	—	Grommet	Yes	3 wire	—	5V	—	—	Z76	●	●	—	IC circuit	—	P. 59
				2 wire	24V	12V	100V	—	Z73	●	●	●	—		
Reed switch	—	Grommet	No	2 wire	—	5V	100V or less	—	Z80	●	●	—	IC circuit	—	P. 59
				3 wire (NPN)	—	5V	12V	—	Y69A	Y59A	●	●	○		
Solid state switch	Diagnostic indication (2 color indicator)	Grommet	Yes	3 wire (PNP)	—	12V	—	—	Y7PV	Y7P	●	●	○	IC circuit	P. 60
				2 wire	—	12V	—	—	Y69B	Y59B	●	●	○	—	
Solid state switch	Water resistant (2 color indicator)	Grommet	Yes	3 wire (NPN)	24V	5V	—	—	Y7NWV	Y7NW	●	●	○	IC circuit	P. 61
				3 wire (PNP)	—	12V	—	—	Y7PWV	Y7PW	●	●	○	—	
Solid state switch	Magnetic field resistant (2 color indicator)	Grommet	Yes	2 wire	—	12V	—	—	Y7BWV	Y7BW	●	●	○	—	P. 62
				—	—	—	—	—	Y7BA	—	—	●	○	—	
Solid state switch	—	Grommet	No	2 wire	—	—	—	—	Y7BA	—	—	●	○	—	P. 62
				—	—	—	—	—	—	—	—	●	●	—	
Solid state switch	—	Grommet	No	2 wire	—	—	—	—	P5DW ^{Note 3)}	—	●	●	—	—	P. 63
				—	—	—	—	—	—	—	—	—	—	—	

Note 1) Lead wire symbols 0.5m Nil (Example) Y69B
 3m L Y69BL
 5m Z Y69BZ

Note 2) Solid state auto switches marked with a "○" are produced upon receipt of order.

Note 3) Type D-P5DW cannot be mounted on bore sizes of ø32 or less.



Specifications

Action	Double acting	
Fluid	Air	
Proof pressure	1.5MPa	
Maximum operating pressure	1.0MPa	
Minimum operating pressure	0.15MPa *	
Ambient and fluid temperature	-10 to 60°C (with no freezing)	
Piston speed	ø20 to ø63	50 to 500mm/s
	ø80, ø100	50 to 400mm/s
Cushion	Rubber bumper at both ends	
Lubrication	Non-lube	
Stroke length tolerance	$^{+1.5}_0$ mm	

* 0.1MPa except for the lock unit.

Lock Specifications

Lock position	Rear, Front side							
Holding force (max.) N	ø20	ø25	ø32	ø40	ø50	ø63	ø80	ø100
	215	330	550	860	1340	2140	3450	5390
Backlash	2mm or less							
Manual release	Non-locking type, Locking type							

Adjust switch positions for operation at both the stroke end and backlash (2mm) movement positions.

Standard Strokes

Bore size (mm)	Standard stroke (mm)
20, 25, 32, 40, 50, 63, 80, 100	25, 50, 75, 100, 125, 150, 175, 200, 250, 300, 350, 400

Manufacture of Intermediate Strokes

Modification method	Spacer installation type Spacers are installed in a standard stroke cylinder. Available in 5mm stroke increments
Part number	Refer to page 35 for standard part numbers and ordering procedure.
Applicable stroke (mm)	5 to 395
Example	Part no.: MGPM50-35-HN A spacer 15mm in width is installed in a MGPM50-50-HN . C dimension is 119mm.

Note 1) The minimum stroke for mounting auto switches is 10mm or more for two switches, and 5mm or more for one switch.

Note 2) Intermediate strokes (in 1mm increments) with a special body are available by special order.

Auto switch mounting bracket part no. for D-P5DW

Bore size (mm)	Mounting bracket part no.	Notes
40, 50, 63, 80, 100	BMG1-040	Switch mounting bracket Hexagon socket head cap screw (M2.5 x 0.45 x 8) 2 pcs. Hexagon socket head cap screw (M3 x 0.5 x 16) 2 pcs. Spring washer (nominal size 3)

Theoretical Output

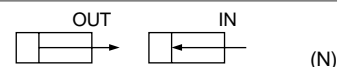

Bore size (mm)	Rod size (mm)	Operating direction	Piston area (mm ²)	Operating pressure (MPa)									
				0.2	0.3	0.4	0.5	0.6	0.7	0.8	0.9	1.0	
20	10	OUT	314	63	94	126	157	188	220	251	283	314	
		IN	236	47	71	94	118	142	165	189	212	236	
25	12	OUT	491	98	147	196	246	295	344	393	442	491	
		IN	378	76	113	151	189	227	265	302	340	378	
32	16	OUT	804	161	241	322	402	482	563	643	724	804	
		IN	603	121	181	241	302	362	422	482	543	603	
40	16	OUT	1257	251	377	503	629	754	880	1006	1131	1257	
		IN	1056	211	317	422	528	634	739	845	950	1056	
50	20	OUT	1963	393	589	785	982	1178	1374	1570	1767	1963	
		IN	1649	330	495	660	825	990	1154	1319	1484	1649	
63	20	OUT	3117	623	935	1247	1559	1870	2182	2494	2805	3117	
		IN	2803	561	841	1121	1402	1682	1962	2242	2523	2803	
80	25	OUT	5027	1005	1508	2011	2514	3016	3519	4022	4524	5027	
		IN	4536	907	1361	1814	2268	2722	3175	3629	4082	4536	
100	30	OUT	7854	1571	2356	3142	3927	4712	5498	6283	7069	7854	
		IN	7147	1429	2144	2859	3574	4288	5003	5718	6432	7147	

Note) Theoretical output (N) = Pressure (MPa) x Piston area (mm²)

Weights

Slide bearing: MGPM20 to 100 (Basic weight)

Bore size (mm)	Model	Standard stroke (mm)											
		25	50	75	100	125	150	175	200	250	300	350	400
20	MGPM20	0.86	1.12	1.32	1.52	1.71	1.91	2.11	2.31	2.78	3.18	3.57	3.97
25	MGPM25	1.18	1.56	1.83	2.10	2.38	2.65	2.92	3.19	3.85	4.39	4.94	5.48
32	MGPM32	1.92	2.32	2.70	3.09	3.47	3.85	4.23	4.61	5.56	6.32	7.09	7.85
40	MGPM40	2.20	2.66	3.08	3.51	3.93	4.36	4.78	5.20	6.24	7.10	7.95	8.80
50	MGPM50	3.73	4.46	5.10	5.74	6.38	7.02	7.66	8.30	9.91	11.2	12.5	13.8
63	MGPM63	4.61	5.45	6.21	6.96	7.72	8.47	9.23	9.99	11.8	13.3	14.8	16.3
80	MGPM80	7.88	8.70	9.49	10.3	11.2	12.0	12.8	13.9	15.5	17.2	18.8	20.5
100	MGPM100	12.1	13.2	14.4	15.6	16.8	18.0	19.1	20.6	22.9	25.3	27.6	30.0

Ball bushing: MGPL20 to 100 (Basic weight)

Bore size (mm)	Model	Standard stroke (mm)											
		25	50	75	100	125	150	175	200	250	300	350	400
20	MGPL20	0.93	1.10	1.27	1.48	1.65	1.83	2.00	2.17	2.55	2.90	3.25	3.60
25	MGPL25	1.27	1.50	1.74	2.01	2.24	2.47	2.70	2.94	3.44	3.91	4.37	4.83
32	MGPL32	1.74	2.19	2.51	2.88	3.20	3.51	3.83	4.15	4.84	5.47	6.10	6.73
40	MGPL40	2.02	2.51	2.87	3.29	3.65	4.01	4.37	4.73	5.51	6.23	6.95	7.67
50	MGPL50	3.46	4.21	4.76	5.40	5.95	6.50	7.05	7.60	8.83	9.92	11.1	12.2
63	MGPL63	4.33	5.20	5.86	6.62	7.28	7.95	8.61	9.27	10.7	12.1	13.4	14.7
80	MGPL80	8.05	8.87	9.66	10.5	11.4	12.2	13.0	14.1	15.7	17.4	19.0	20.7
100	MGPL100	12.4	13.5	14.7	15.9	17.1	18.3	19.4	20.9	23.2	25.6	27.9	30.3

Lock unit additional weight

Bore size (mm)	With rear lock		With front lock	
	HN	HL	RN	RL
20	0.05	0.07	0.05	0.06
25	0.06	0.07	0.05	0.07
32	0.09	0.10	0.09	0.10
40	0.15	0.18	0.14	0.18
50	0.24	0.27	0.23	0.27

Bore size (mm)	With rear lock		With front lock	
	HN	HL	RN	RL
63	0.36	0.40	0.35	0.39
80	0.90	0.97	1.03	1.10
100	1.52	1.60	1.60	1.68

Calculation (example) MGPM50-100-HN
 • Basic weight + Lock unit additional weight
 • 5.74 + 0.24 = 5.99kg

Allowable Rotational Torque of Plate

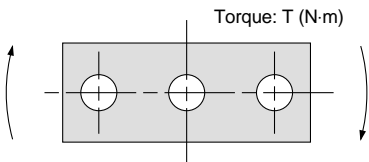

Bore size (mm)	Bearing type	Stroke (mm)											
		25	50	75	100	125	150	175	200	250	300	350	400
20	MGPM	0.99	0.75	1.88	1.63	1.44	1.28	1.16	1.06	0.90	0.78	0.69	0.62
	MGPL	2.66	1.94	1.52	1.25	1.34	1.17	1.03	0.93	0.76	0.65	0.56	0.49
25	MGPM	1.64	1.25	2.96	2.57	2.26	2.02	1.83	1.67	1.42	1.24	1.09	0.98
	MGPL	4.08	3.02	2.38	1.97	2.05	1.78	1.58	1.41	1.16	0.98	0.85	0.74
32	MGPM	6.35	5.13	5.69	4.97	4.42	3.98	3.61	3.31	2.84	2.48	2.20	1.98
	MGPL	5.95	4.89	5.11	4.51	6.34	5.79	5.33	4.93	4.29	3.78	3.38	3.04
40	MGPM	7.00	5.66	6.27	5.48	4.87	4.38	5.98	3.65	3.13	2.74	2.43	2.19
	MGPL	6.55	5.39	5.62	4.96	6.98	6.38	5.87	5.43	4.72	4.16	3.71	3.35
50	MGPM	13.0	10.8	12.0	10.6	9.50	8.60	7.86	7.24	6.24	5.49	4.90	4.43
	MGPL	9.17	7.62	9.83	8.74	11.6	10.7	9.83	9.12	7.95	7.02	6.26	5.63
63	MGPM	14.7	12.1	13.5	11.9	10.7	9.69	8.86	8.16	7.04	6.19	5.52	4.99
	MGPL	10.2	8.48	11.0	9.74	13.0	11.9	11.0	10.2	8.84	7.80	6.94	6.24
80	MGPM	21.9	18.6	22.9	20.5	18.6	17.0	15.6	14.5	12.6	11.2	10.0	9.11
	MGPL	15.1	23.3	22.7	20.6	18.9	17.3	16.0	14.8	12.9	11.3	10.0	8.94
100	MGPM	38.8	33.5	37.5	33.8	30.9	28.4	26.2	24.4	21.4	19.1	17.2	15.7
	MGPL	27.1	30.6	37.9	34.6	31.8	29.3	27.2	25.3	22.1	19.5	17.3	15.5

Non-rotating Accuracy of Plate

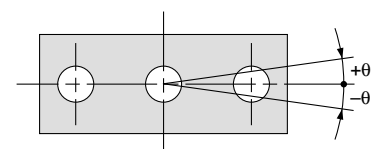

For non-rotating accuracy θ without load, use a value no more than the values in the table as a guide.

Bore size (mm)	Non-rotating accuracy θ	
	MGPM	MGPL
20	$\pm 0.07^\circ$	$\pm 0.09^\circ$
25	$\pm 0.07^\circ$	$\pm 0.09^\circ$
32	$\pm 0.06^\circ$	$\pm 0.08^\circ$
40	$\pm 0.06^\circ$	$\pm 0.08^\circ$
50	$\pm 0.05^\circ$	$\pm 0.06^\circ$
63	$\pm 0.05^\circ$	$\pm 0.06^\circ$
80	$\pm 0.04^\circ$	$\pm 0.05^\circ$
100	$\pm 0.04^\circ$	$\pm 0.05^\circ$

Model selection is the same as MGP/Standard. Refer to page 4.

Series MGP

Auto Switches/Proper Mounting Position for Stroke End Detection

With front lock

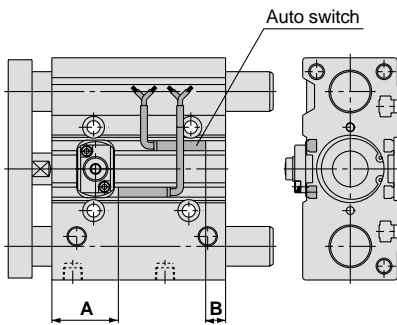

With rear lock

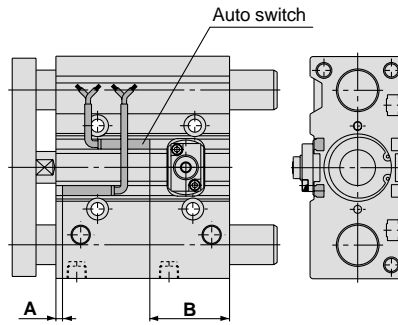

For D-P5DW (* Cannot be mounted on bore sizes $\phi 32$ or less.)

$\phi 40$ to $\phi 63$

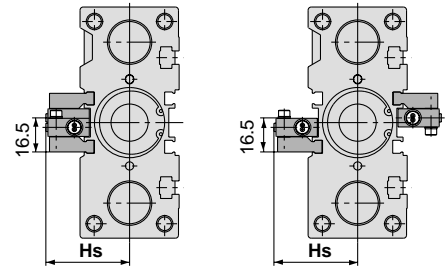

For 25mm stroke

* For bore sizes $\phi 40$ through $\phi 63$ with two switches, one switch is mounted on each side.

$\phi 80, \phi 100$

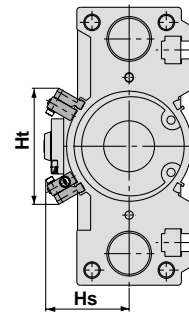

Proper mounting position (mm)

Bore size (mm)	A	B
20	47.5	1.5
25	35.5	1.5
32	32.5	5
40	38.5	5.5
50	38.5	4.5
63	42	7
80	63	18.5
100	67.5	23.5

* Minimum mountable strokes for auto switch are 10mm or more for two switches, and 5mm or more for one switch.

(mm)

Bore size (mm)	A	B
20	4	33
25	5	32.5
32	5.5	32
40	9.5	34.5
50	7.5	36.5
63	10	39
80	13	68.5
100	17.5	73.5

* Minimum mountable strokes for auto switch are 10mm or more for two switches, and 5mm or more for one switch.

(mm)

Bore size (mm)	Hs	Ht
40	44.5	—
50	50	—
63	57	—
80	60.7	84.4
100	70.8	96.1

* Minimum mountable strokes for auto switch are 10mm or more for two switches, and 5mm or more for one switch.

Auto Switch Mounting

⚠ Caution

Auto switch mounting tool

- When tightening the auto switch mounting screw (included with auto switch), use a watchmakers screw driver with a handle about 5 to 6mm in diameter

Tightening torque

- Tighten with a torque of 0.05 to 0.1N·m. As a rule, it should be turned about 90° past the point at which tightening can be felt.

When mounting an auto switch on the side with the end lock, insert the auto switch from the rod side for the rear lock, and from the head side for the front lock.

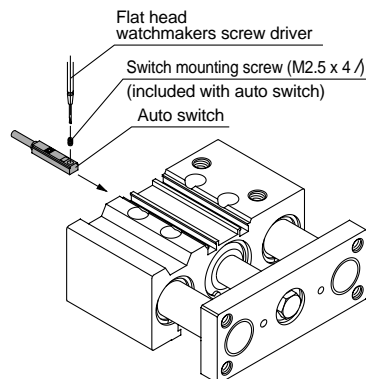

For D-P5DW

⚠ Caution

Auto switch mounting tool

- When tightening hexagon socket head cap screws of the auto switch, use hexagon wrench key 2 or 2.5 with the appropriate screws.

Tightening torque

- Tighten M2.5 screws with a torque of about 0.3 to 0.5N·m, and M3 screws with a torque of about 0.5 to 0.7 N·m.

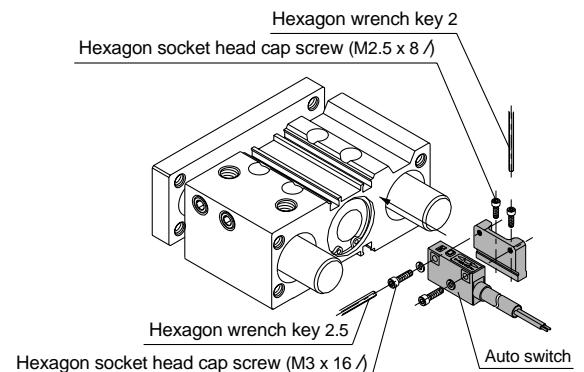

Construction

Series MGPM

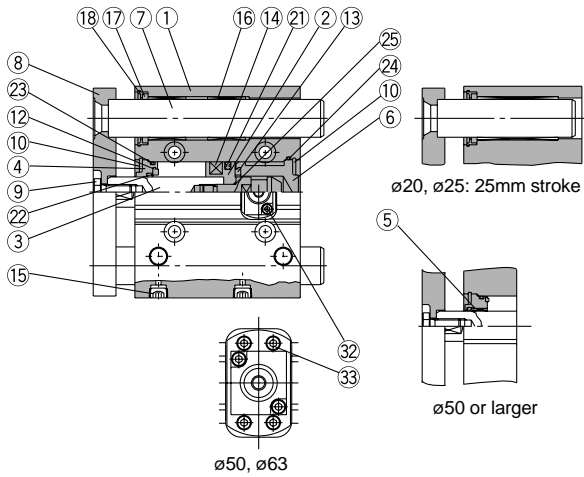

Series MGPL

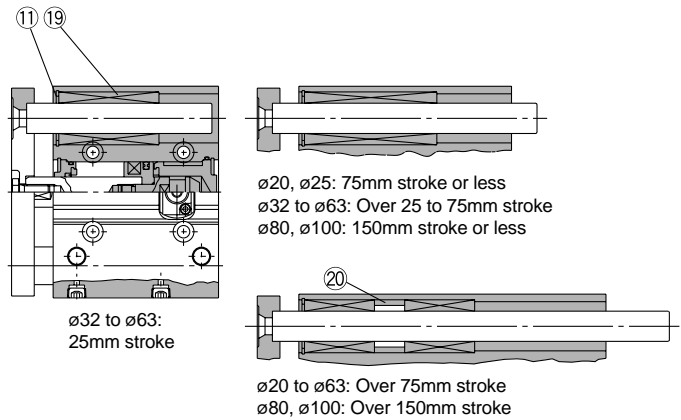

Non-locking type

(Rear side lock)

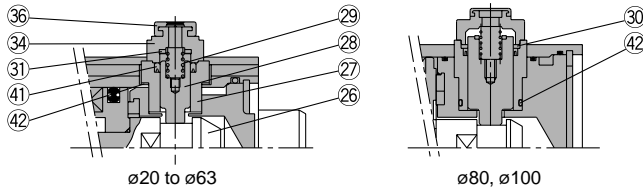

Locking type

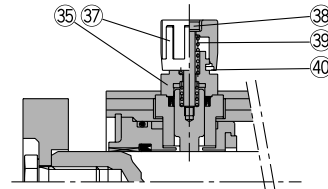

(With front lock)

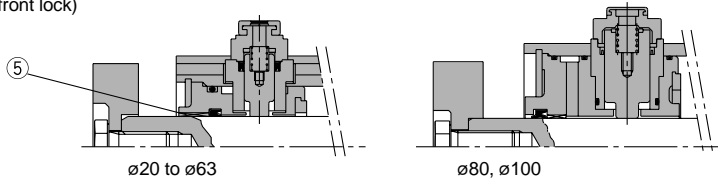

Parts list

No.	Description	Material	Note
1	Body	Aluminum alloy	Hard anodized
2	Piston	Aluminum alloy	Chromated
3	Piston rod	Stainless steel	Hard chrome plated with front end lock only
		Carbon steel	
4	Collar	Aluminum alloy	Clear anodized
5	Bushing	Lead bronze casting	
6	Head cover	Aluminum alloy	Colorless chromated
7	Guide rod	Carbon steel	Hard chrome plated
8	Plate	Carbon steel	Nickel plated
9	Plate mounting bolt	Carbon steel	Nickel plated
10	Snap ring	Carbon tool steel	Phosphate coated
11	Snap ring	Carbon tool steel	Phosphate coated
12	Bumper A	Urethane	
13	Bumper B	Urethane	
14	Magnet	Synthetic rubber	
15	Hexagon socket head taper plug	Carbon steel	Nickel plated
16	Slide bearing	Lead bronze casting	
17	Felt	Felt	
18	Holder	Resin	
19	Ball bushing		
20	Spacer	Aluminum alloy	
21*	Piston seal	NBR	

Replacement parts: Seal kits

Bore size (mm)	Kit No.	Contents
20	MGP20-B-PS	Kits include items 21, 22, 23, 24, 32, 33, 41 and 42 from the table above.
25	MGP25-B-PS	
32	MGP32-B-PS	
40	MGP40-B-PS	
50	MGP50-B-PS	

* Seal kits are sets consisting of items 21 through 24, 32, 33, 41 and 42 above, and can be ordered using the kit number for each bore size.

Parts list

No.	Description	Material	Note
22*	Rod seal	NBR	
23*	Gasket A	NBR	
24*	Gasket B	NBR	
25	Piston gasket	NBR	ø32 to ø100 only
26	Lock bolt	Carbon steel	Zinc chromated
27	Lock holder	Brass	Electroless nickel plated
28	Lock piston	Carbon steel	Nickel plated
29	Lock spring	Stainless steel	
30	Seal retainer	Carbon steel	Zinc chromated (ø80, ø100 only)
31	Bumper	Urethane	
32*	Hexagon socket head cap screw	Carbon steel	Black zinc chromated
33*	Hexagon socket head cap screw	Carbon steel	Nickel plated (ø50, ø63 only)
34	Cap A	Die-cast aluminum	Black coated
35	Cap B	Carbon steel	SQ treated
36	Rubber cap	Synthetic rubber	
37	M/O knob	Die-cast zinc	Black coated
38	M/O bolt	Alloy steel	Black zinc chromated
39	M/O spring	Steel wire	Chromated
40	Stopper ring	Carbon steel	Chromated
41*	Lock piston seal	NBR	
42*	Lock holder gasket	NBR	

Replacement parts: Seal kits

Bore size (mm)	Kit no.	Contents
63	MGP63-B-PS	Kits include items 21, 22, 23, 24, 32, 33, 41 and 42 from the table above.
80	MGP80-B-PS	
100	MGP100-B-PS	

* Items 32 and 33 are not included for bores sizes 80 and 100.

Series MGP

Dimensions/Ø20, Ø25

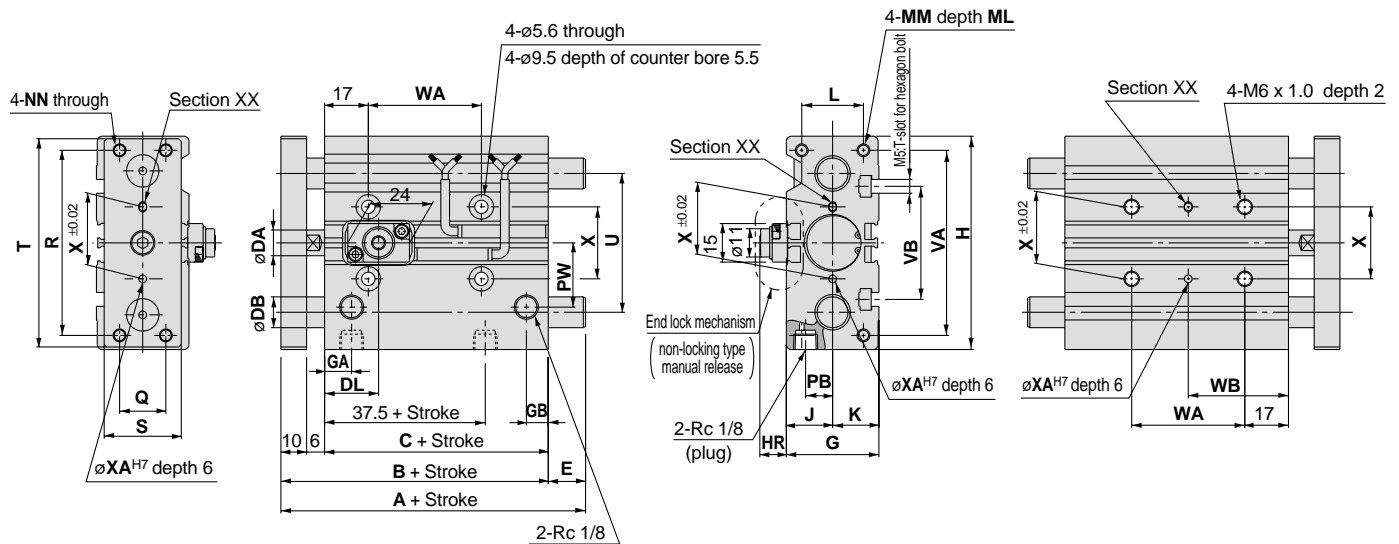

With front lock

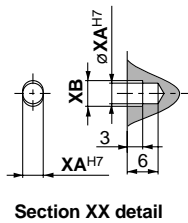

Section XX detail

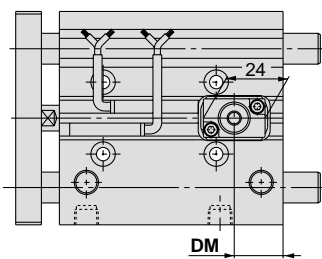

With rear lock

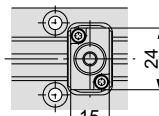

For Ø25

End lock mechanism (Locking type manual release)

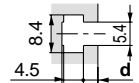
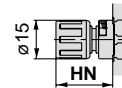

T-slot dimensions (mm)

Bore size (mm)	d	e
20	2.8	7.8
25	3	8.2



Refer to "Manufacture of Intermediate Strokes" on page 36 for intermediate strokes.

Bore size (mm)	Standard stroke (mm)	B	C	DA	G	GA	GB	H	J	K	L	MM	ML	NN	PB	PW	Q	R
20	25, 50, 75, 100, 125, 150, 175	78	62	10	36	10.5	8.5	83	18	18	24	M5 x 0.8	13	M5 x 0.8	10.5	25	18	70
25	200, 250, 300, 350, 400	78.5	62.5	12	42	11.5	9	93	21	21	30	M6 x 1.0	15	M6 x 1.0	13.5	28.5	26	78

Bore size (mm)	S	T	U	VA	VB	WA				WB				X	XA	XB
						75st or less	Over 75st to 175st	Over 175st to 250st	Over 250st	75st or less	Over 75st to 175st	Over 175st to 250st	Over 250st			
20	30	81	54	72	44	44	120	200	300	39	77	117	167	28	3	3.5
25	38	91	64	82	50	44	120	200	300	39	77	117	167	34	4	4.5

End lock mechanism dimensions (mm)

Bore size (mm)	DL	DM	HR	HN
20	21	19	10.5	22
25	26.5	16	8	19.5

MGPM (slide bearing)/Dimensions A, DB, E (mm)

Bore size (mm)	A			DB	E		
	75st or less	Over 75st to 175st	Over 175st		75st or less	Over 75st to 175st	Over 175st
20	78	84.5	122	12	0	6.5	44
25	78.5	85	122	16	0	6.5	43.5

MGPL (ball bushing)/Dimensions A, DB, E (mm)

Bore size (mm)	A			DB	E		
	25st or less	Over 25st to 175st	Over 175st		25st or less	Over 25st to 175st	Over 175st
20	80	104	122	10	2	26	44
25	85.5	104.5	122	13	7	26	43.5

Dimensions/Ø32 to Ø63

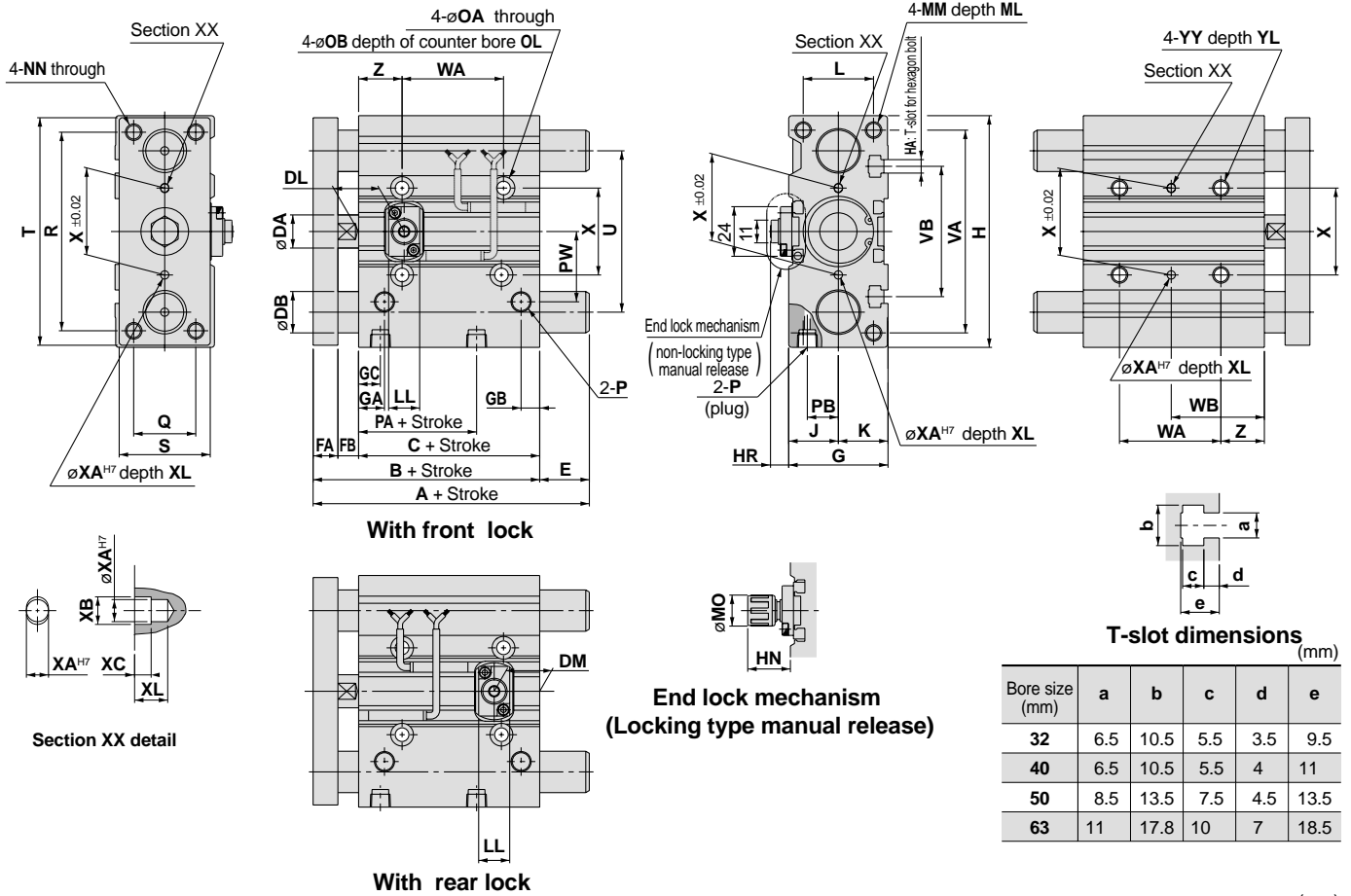

T-slot dimensions (mm)

Bore size (mm)	a	b	c	d	e
32	6.5	10.5	5.5	3.5	9.5
40	6.5	10.5	5.5	4	11
50	8.5	13.5	7.5	4.5	13.5
63	11	17.8	10	7	18.5

Bore size (mm)	Standard stroke (mm)	B	C	DA	FA	FB	G	GA	GB	GC	H	HA	J	K	L	MM	ML	NN	OA
32	25, 50, 75, 100	84.5	62.5	16	12	10	48	12.5	9	12.5	112	M6	24	24	34	M8 x 1.25	20	M8 x 1.25	6.6
40	125, 150, 175	91	69	16	12	10	54	14	10	14	120	M6	27	27	40	M8 x 1.25	20	M8 x 1.25	6.6
50	200, 250, 300	97	69	20	16	12	64	14	11	12	148	M8	32	32	46	M10 x 1.5	22	M10 x 1.5	8.6
63	350, 400	102	74	20	16	12	78	16.5	13.5	16.5	162	M10	39	39	58	M10 x 1.5	22	M10 x 1.5	8.6

Bore size (mm)	OB	OL	P	PA	PB	PW	Q	R	S	T	U	VA	VB	WA				WB			
														75st or less	Over 75st to 175st	Over 175st to 275st	Over 275st	75st or less	Over 75st to 175st	Over 175st to 275st	Over 275st
32	11	7.5	Rc 1/8	32	15	34	30	96	44	110	78	98	63	48	124	200	300	45	83	121	171
40	11	7.5	Rc 1/8	38	18	38	30	104	44	118	86	106	72	48	124	200	300	46	84	122	172
50	14	9	Rc 1/4	34	21.5	47	40	130	60	146	110	130	92	48	124	200	300	48	86	124	174
63	14	9	Rc 1/4	39	28	55	50	130	70	158	124	142	110	52	128	200	300	50	88	124	174

MGPM (slide bearing)/Dimensions A, DB, E (mm)

Bore size (mm)	X	XA	XB	XC	XL	YY	YL	Z
40	50	4	4.5	3	6	M8 x 1.25	16	22
50	66	5	6	4	8	M10 x 1.5	20	24
63	80	5	6	4	8	M10 x 1.5	20	24

MGPM (slide bearing)/Dimensions A, DB, E (mm)

Bore size (mm)	A			DB	E		
	25st or less	Over 25st to 175st	Over 175st		25st or less	Over 25st to 175st	Over 175st
32	97	102	140	20	12.5	17.5	55.5
40	97	102	140	20	6	11	49
50	106.5	118	161	25	9.5	21	64
63	106.5	118	161	25	4.5	16	59

End lock mechanism (mm)

Bore size (mm)	DL	DM	HR	HN (max.)	LL	MO
32	22	22	9.5	21	15	15
40	26	23	11.5	25.5	21	19
50	24	23	13	27	21	19
63	25	25.5	11	25	21	19

MGPL (ball bushing)/Dimensions A, DB, E (mm)

Bore size (mm)	A				DB	E			
	25st or less	Over 25st to 175st	Over 175st	Over 175st		25st or less	Over 25st to 175st	Over 175st	Over 175st
32	84.5	98	118	140	16	0	13.5	33.5	55.5
40	91	98	118	140	16	0	7	27	49
50	97	114	134	161	20	0	17	37	64
63	102	114	134	161	20	0	12	32	59

Standard Type
MGP

With Air Cushion
MGP

With End Lock
MGP

Heavy Duty
Guide Rod Type
MGPS

Order Made
Specifications

Auto Switches

Precautions

Series MGP

Dimensions/Ø80, Ø100

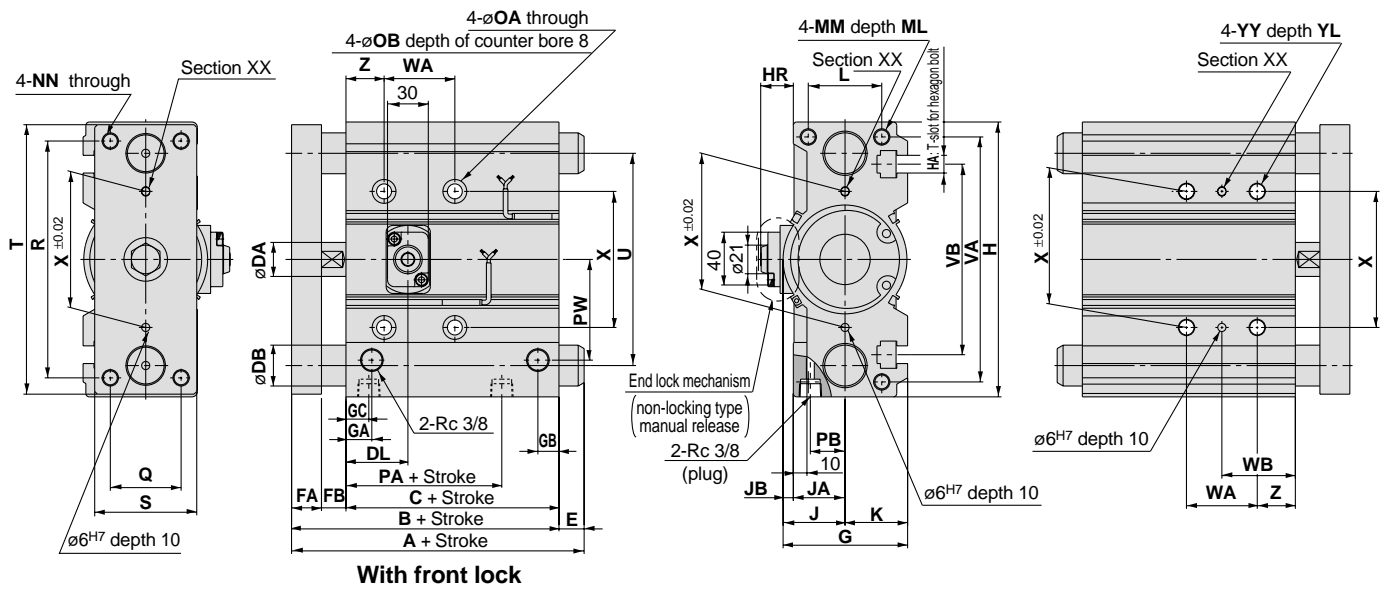

With front lock

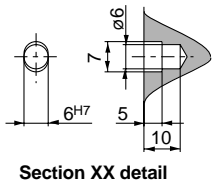

Section XX detail

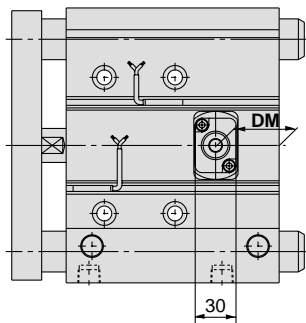

With rear lock

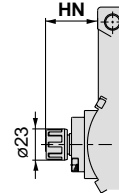

End lock mechanism (Locking type manual release)

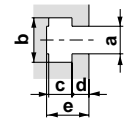

T-slot dimensions

Bore size (mm)	(mm)				
	a	b	c	d	e
80	13.3	20.3	12	8	22.5
100	15.3	23.3	13.5	10	30

Bore size (mm)	Standard stroke (mm)	(mm)															
		B	C	DA	FA	FB	G	GA	GB	GC	H	HA	J	JA	JB	K	L
80	25, 50, 75, 100, 125, 150, 175	146.5	106.5	25	22	18	91.5	19	15.5	14.5	202	M12	45.5	38	7.5	46	54
100	200, 250, 300, 350, 400	166	116	30	25	25	111.5	23	19	18	240	M14	55.5	45	10.5	56	62

Bore size (mm)	MM	ML	NN	OA	OB	PA	PB	PW	Q	R	S	T	U	VA	VB	WA			
																50st or less	Over 50st to 150st	Over 150st to 250st	Over 250st
80	M12 x 1.75	25	M12 x 1.75	10.6	17.5	64.5	25.5	74	52	174	75	198	156	180	140	52	128	200	300
100	M14 x 2.0	31	M14 x 2.0	12.5	20	67.5	32.5	89	64	210	90	236	188	210	166	72	148	220	320

Bore size (mm)	WB				X	YY	YL	Z
	50st or less	Over 50st to 150st	Over 150st to 250st	Over 250st				
80	54	92	128	178	100	M12 x 1.75	24	28
100	47	85	121	171	124	M14 x 2.0	28	11

End lock mechanism dimensions (mm)

Bore size (mm)	DL	DM	HR	HN
	80	45.5	40.5	24
100	49	43.5	26.5	41

MGPM (side bearing)/Dimensions/A, DB, E (mm)

Bore size (mm)	A		DB	E	
	150st or less	Over 150st		150st or less	Over 150st
80	146.5	193	30	0	46.5
100	166	203	36	0	37

MGPL (ball bushing)/Dimensions A, DB, E (mm)

Bore size (mm)	A		DB	E	
	150st or less	Over 150st		150st or less	Over 150st
80	160	193	25	13.5	46.5
100	180	203	30	14	37

Compact Guide Cylinder: Heavy Duty Guide Rod Type

Series *MGPS*

ø50, ø80

How to Order

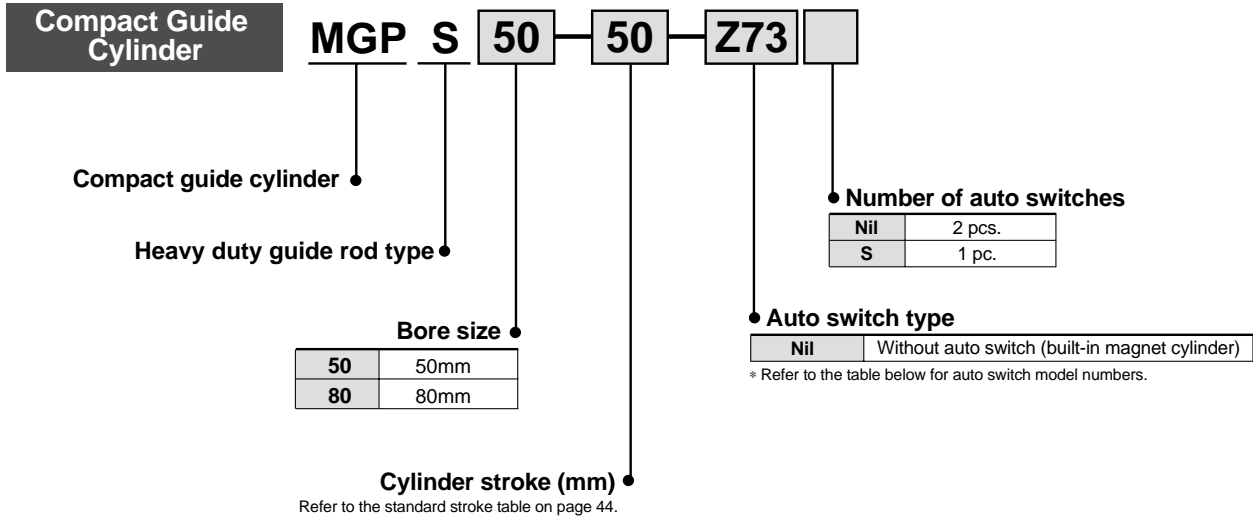

Applicable auto switches

Type	Special function	Electrical entry	Indicator light	Wiring (output)	Load voltage		Auto switch model		Lead wire length (m) ^{Note 1)}			Applicable load		Detailed specifications	
					DC	AC	Electrical entry direction		0.5 (Nil)	3 (L)	5 (Z)	IC circuit	Relay, PLC		
							Perpendicular	In-line							
Reed switch	—	Grommet	Yes	3 wire	—	5V	—	Z76	●	●	—	IC circuit	—	P. 59	
				2 wire	24V	12V	100V	—	Z73	●	●	●	—		Relay, PLC
						5V 12V	100V or less	—	Z80	●	●	—	IC circuit		—
Solid state switch	—	Grommet	Yes	3 wire (NPN)	24V	5V 12V	—	Y69A	Y59A	●	●	○	IC circuit	Relay, PLC	P. 60
				3 wire (PNP)				Y7PV	Y7P	●	●	○	—		
				2 wire				Y69B	Y59B	●	●	○	—		
				3 wire (NPN)				Y7NWV	Y7NW	●	●	○	IC circuit		
	Diagnostic indication (2 color indicator)	Grommet	Yes	2 wire	24V	12V	—	Y7PWV	Y7PW	●	●	○	—	Relay, PLC	P. 61
								Y7BWV	Y7BW	●	●	○	—	—	P. 62
								—	Y7BA	—	●	○	—	—	P. 63
Water resistant (2 color indicator)	Grommet	Yes	2 wire	24V	—	—	—	P5DW	—	●	●	—	—	P. 63	
							—	—	—	●	●	—	—	—	

Note 1) Lead wire symbols 0.5m Nil (Example) Y69B
 3m L Y69BL
 5m Z Y69BZ

Note 2) Solid state auto switches marked with a "○" are produced upon receipt of order.

Standard Type
MGP

With Air Cushion
MGP

With End Lock
MGP

Heavy Duty
Guide Rod Type
MGPS

Order Made
Specifications

Auto Switches

Precautions

Series MGPS



Specifications

Action	Double acting
Fluid	Air
Proof pressure	1.5MPa
Maximum operating pressure	1.0MPa
Minimum operating pressure	0.1MPa
Ambient and fluid temperature	-10 to 60°C (with no freezing)
Piston speed	50 to 400mm/s
Cushion	Rubber bumper at both ends
Lubrication	Non-lube
Stroke length tolerance	$^{+1.5}_0$ mm

Standard Strokes

Bore size (mm)	Standard stroke (mm)
50, 80	25, 50, 75, 100, 125, 150, 175, 200

Manufacture of Intermediate Strokes

Modification method	Spacer installation type Spacers are installed in a standard stroke cylinder. Available in 5mm stroke increments
Part number	Refer to page 43 for standard part numbers and ordering procedure.
Applicable stroke (mm)	5 to 195
Example	Part no.: MGPS50—35 A spacer 15mm in width is installed in a MGPS50—50 . C dimension is 94mm.

Note 1) The minimum stroke for mounting auto switches is 10mm or more for two switches, and 5mm or more for one switch.
Note 2) Intermediate strokes (in 1mm increments) with a special body are available by special order.

Theoretical Output

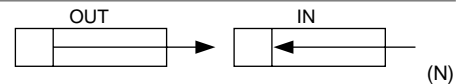

Auto switch mounting bracket part no. for D-P5DW

Bore size (mm)	Mounting bracket part no.	Notes
50, 80	BMG1-040	Switch mounting bracket Hexagon socket head cap screw (M2.5 x 0.45 x 8 /) 2 pcs. Hexagon socket head cap screw (M3 x 0.5 x 16 /) 2 pcs. Spring washer (nominal size 3)

Bore size (mm)	Rod size (mm)	Operating direction	Piston area (mm ²)	Operating pressure (MPa)								
				0.2	0.3	0.4	0.5	0.6	0.7	0.8	0.9	1.0
50	20	OUT	1963	393	589	785	982	1178	1374	1571	1767	1963
		IN	1649	330	495	660	825	990	1155	1319	1484	1649
80	25	OUT	5027	1005	1508	2011	2513	3016	3519	4021	4524	5027
		IN	4536	907	1361	1814	2268	2721	3175	3629	4082	4536

Note) Theoretical output (N) = Pressure (MPa) x Piston area (mm²)

Weights

Bore size (mm)	Model	Standard stroke (mm)							
		25	50	75	100	125	150	175	200
50	MGPS50	3.90	4.68	5.74	6.52	7.30	8.08	8.86	9.64
80	MGPS80	9.21	10.7	13.0	14.5	15.9	17.9	18.9	20.3

Allowable Rotational Torque of Plate

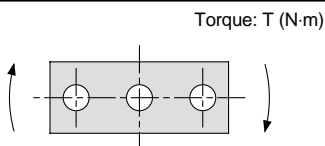

Bore size (mm)	Model	Standard stroke (mm)							
		25	50	75	100	125	150	175	200
50	MGPS50	15	12	16	15	13	12	11	9.8
80	MGPS80	49	41	51	45	41	38	35	32

Non-rotating Accuracy of Plate

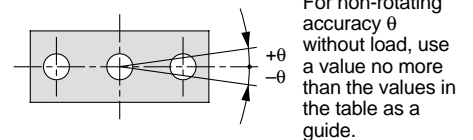

Bore size (mm)	Model	Non-rotating accuracy θ
50	MGPS50	$\pm 0.05^\circ$
80	MGPS80	$\pm 0.04^\circ$

Series MGPS Model Selection

Selecting Conditions

Mounting orientation	Vertical		Horizontal	
Maximum speed (mm/s)	200	400	200	400
Graph (Slide bearing type)	1, 2	3, 4	5, 6	7, 8

Selection Example 1 (Vertical Mounting)

Selecting conditions

Mounting: Vertical
Stroke: 50mm
Maximum speed: 200mm/s
Load weight: 100kg
Eccentric distance: 100mm

Find the point of intersection for the load weight of 100kg and the eccentric distance of 100mm on graph **1**, based on vertical mounting, 50mm stroke, and the speed of 200mm/s.

→MGPS80-50 is selected.

Selection Example 2 (Horizontal Mounting)

Selecting conditions

Mounting: Horizontal
Distance between plate and load center of gravity: 50mm
Maximum speed: 200mm/s
Load weight: 30kg
Stroke: 100mm

Find the point of intersection for the load weight of 30kg and stroke of 100mm on graph **5**, based on horizontal mounting, the distance of 50mm between the plate and load center of gravity, and the speed of 200mm/s.

→MGPS80-100 is selected.

1 50mm stroke or less V = 200mm/s

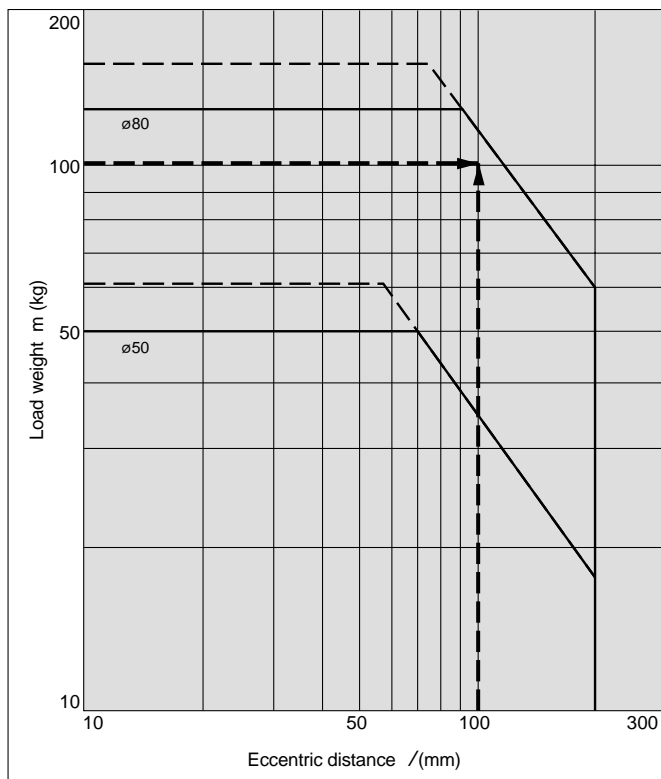

5 l = 50mm V = 200mm/s

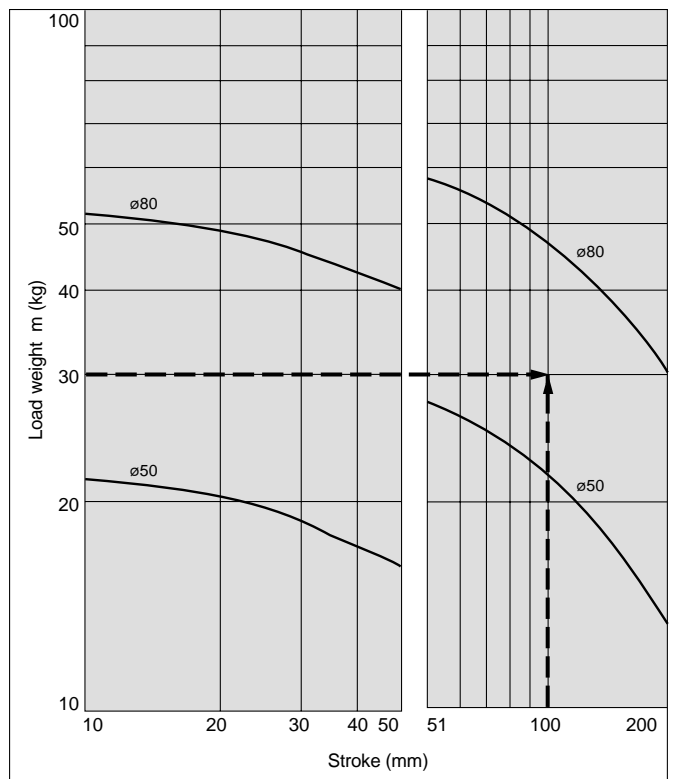

Series MGPS

Vertical Mounting **Slide Bearing**

— Operating pressure: 0.4MPa
 - - - - - Operating pressure: 0.5MPa or more

MGPS50, 80

1 50mm stroke or less V = 200mm/s

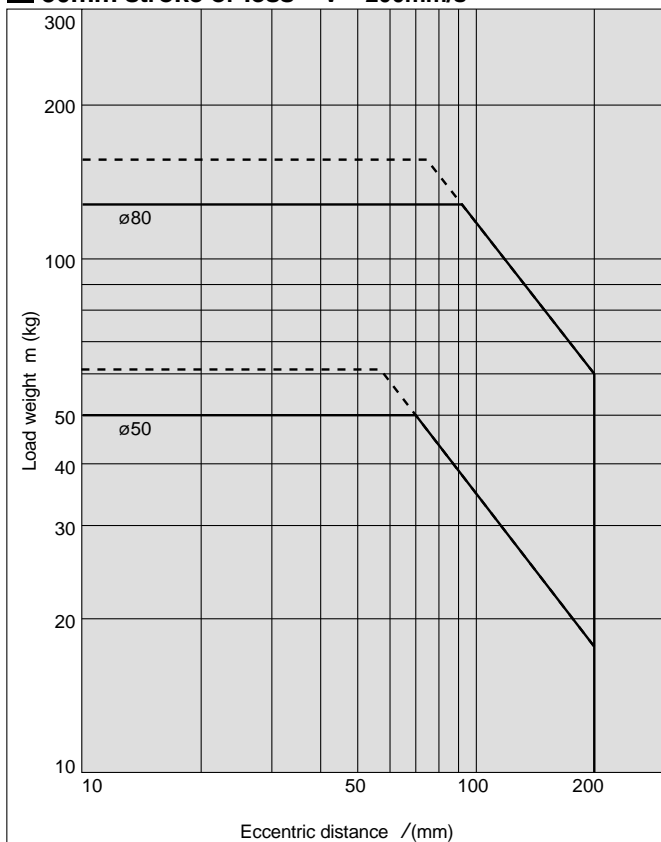

2 Over 50mm stroke V = 200mm/s

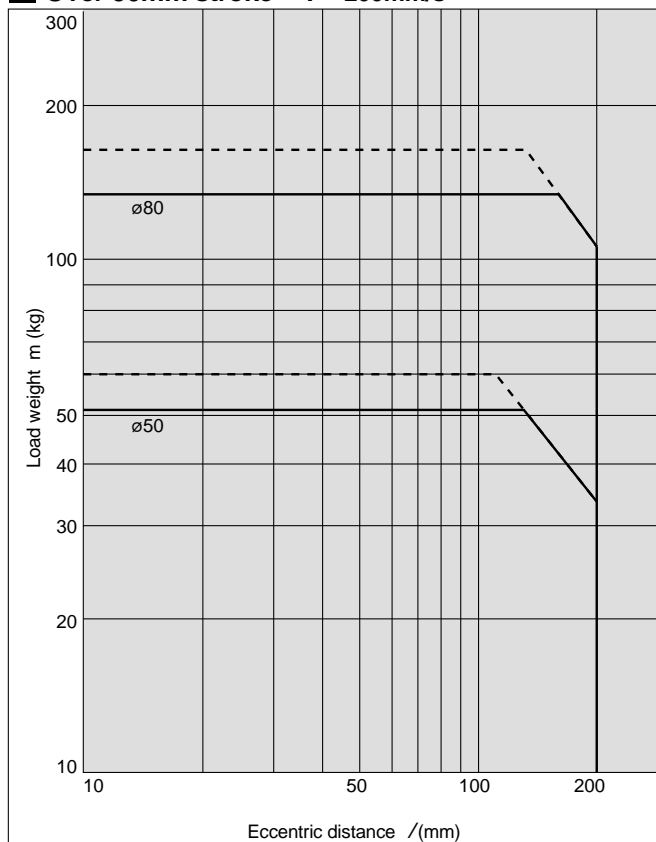

3 50mm stroke or less V = 400mm/s

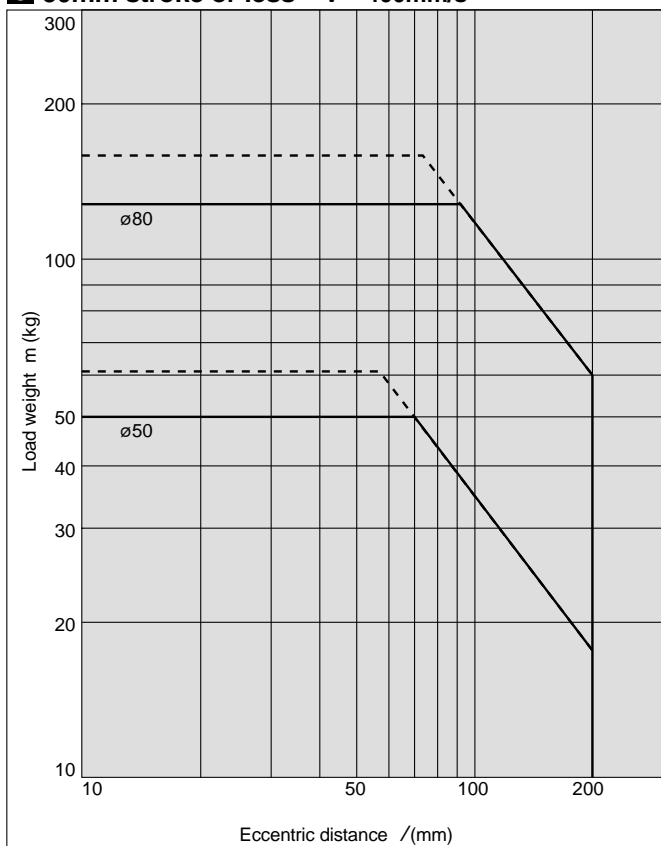

4 Over 50mm stroke V = 400mm/s

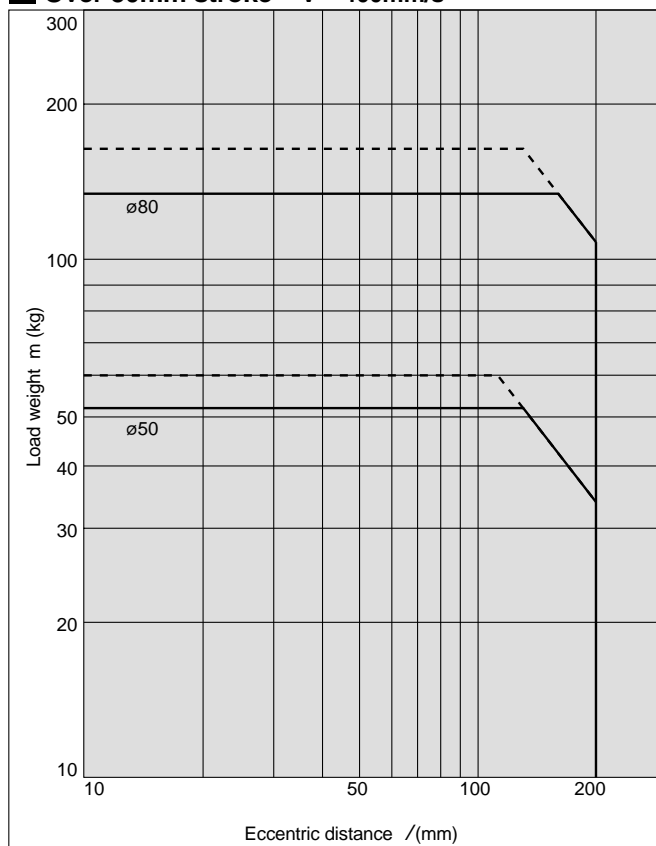

Horizontal Mounting Slide Bearing

MGPS50, 80

5 $\phi = 50\text{mm}$ $V = 200\text{mm/s}$

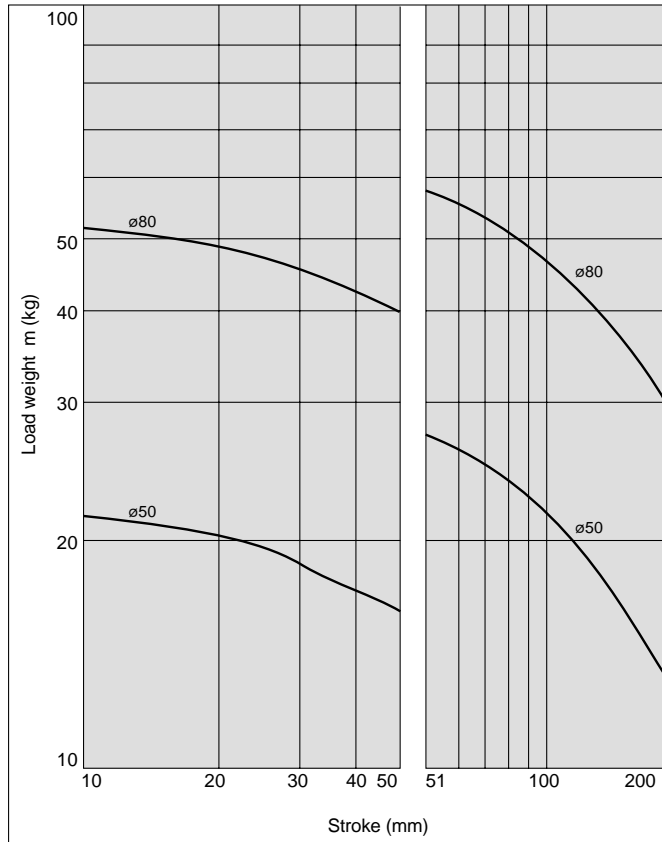

6 $\phi = 100\text{mm}$ $V = 200\text{mm/s}$

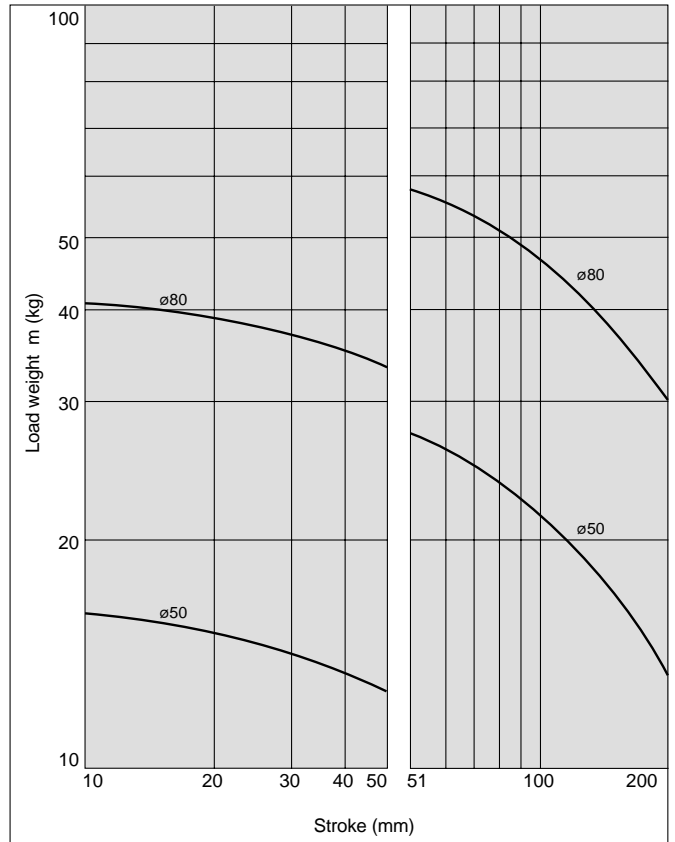

7 $\phi = 50\text{mm}$ $V = 400\text{mm/s}$

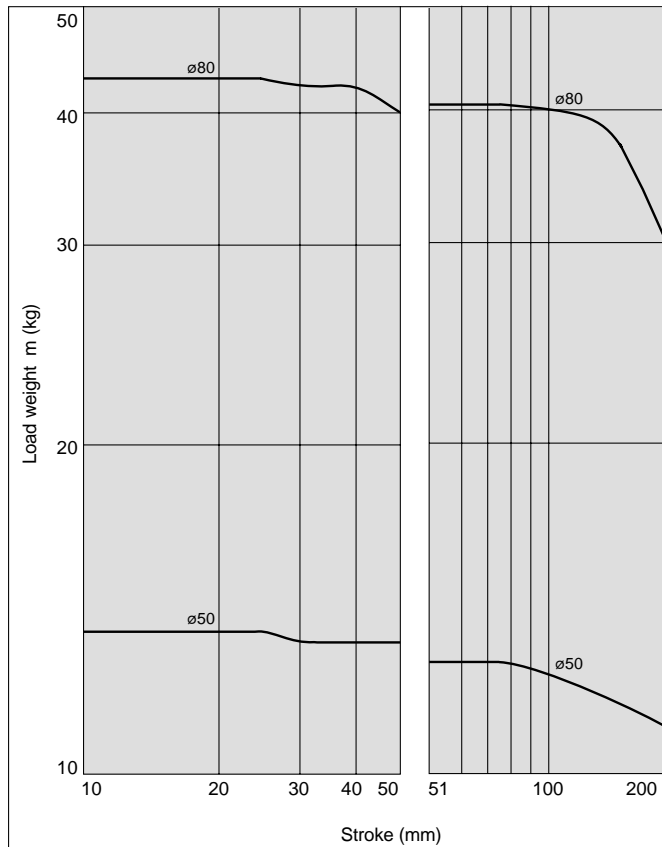

8 $\phi = 100\text{mm}$ $V = 400\text{mm/s}$

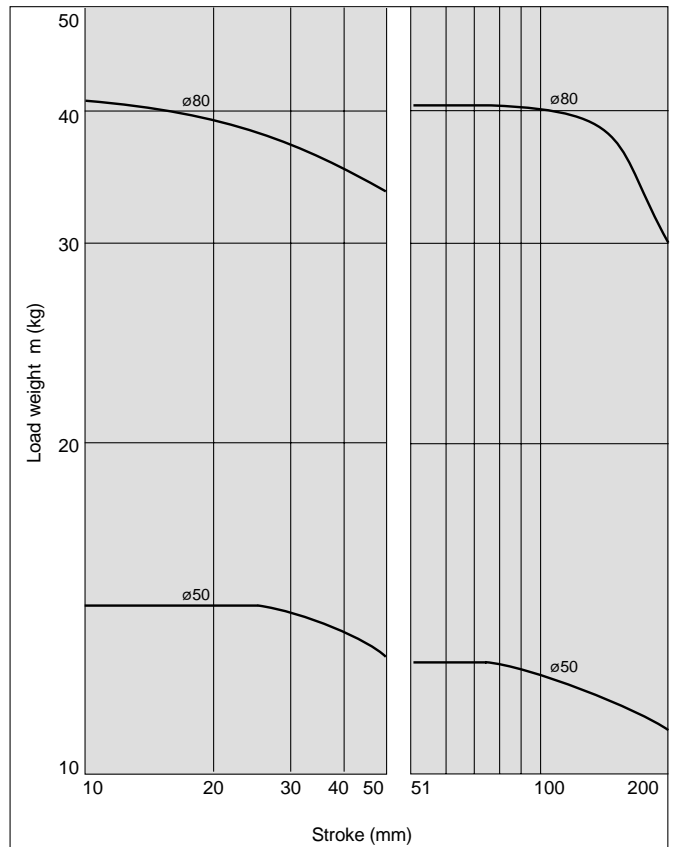

Standard Type
MGP

With Air Cushion
MGP

With End Lock
MGP

Heavy Duty
Guide Rod Type
MGPS

Order Made
Specifications

Auto Switches

Precautions

Series MGPS

Operating Range when Used as Stopper

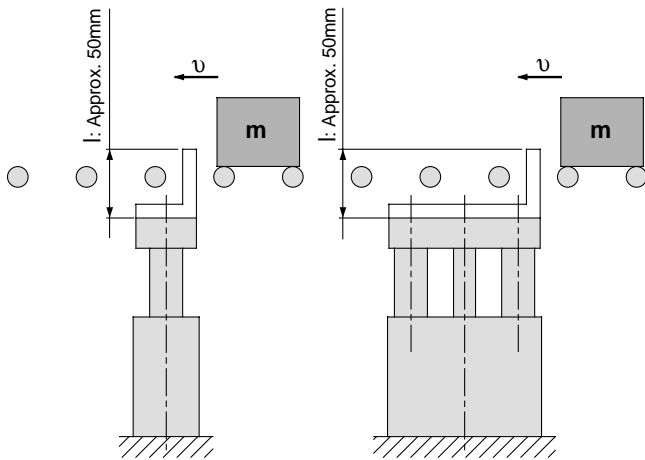

* When selecting a model with a longer l /dimension, be sure to choose a bore size which is sufficiently large.

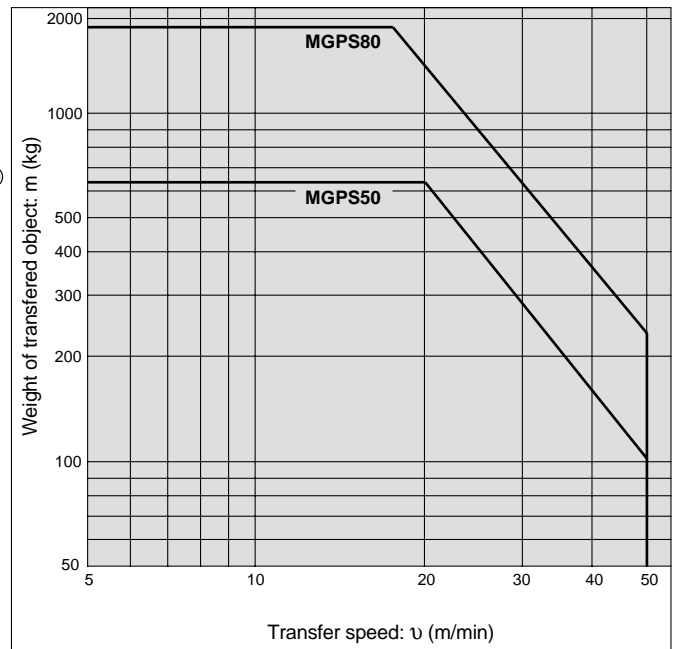

⚠ Caution

Handling precautions

Note) When using as a stopper, select a model with a stroke of 50mm or less.

Auto Switches/Proper Mounting Position for Stroke End Detection

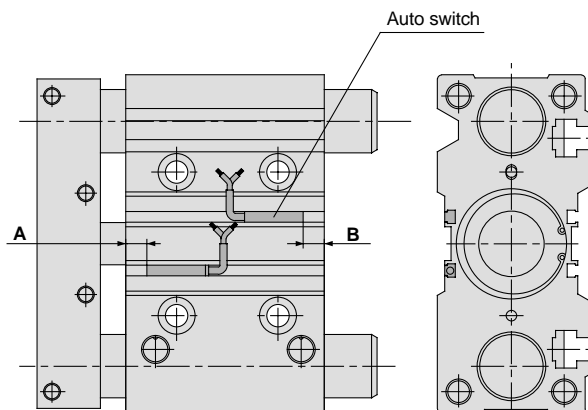

Proper mounting position (mm)

Bore size (mm)	A	B
50	7.5	11.5
80	13	37

Note) Minimum mountable strokes for auto switch are 10mm or more for two switches, and 5mm or more for one switch.

For D-P5DW ø50

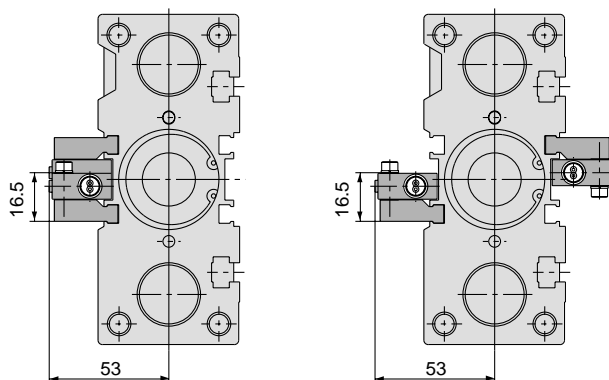

For 25mm stroke
* For bore sizes ø40 through 63 with two switches, one switch is mounted on each side.

ø80

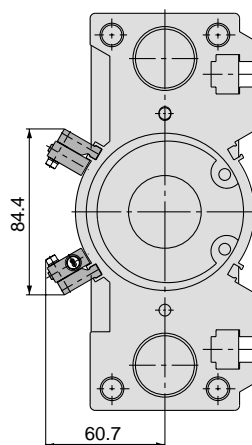

Auto Switch Mounting

⚠ Caution

Auto switch mounting tool

- When tightening the auto switch mounting screw (included with auto switch), use a watchmakers screw driver with a handle about 5 to 6mm in diameter.

Tightening torque

- Tighten with a torque of 0.05 to 0.1N·m. As a rule, it should be turned about 90° past the point at which tightening can be felt.

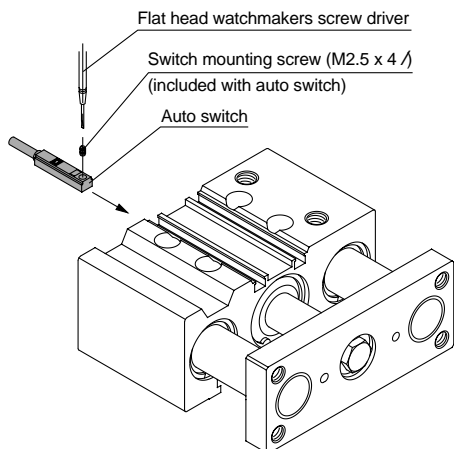

For D-P5DW

⚠ Caution

Auto switch mounting tool

- When tightening hexagon socket head cap screws of the auto switch, use hexagon wrench key 2 or 2.5 with the appropriate screws.

Tightening torque

- Tighten M2.5 screws with a torque of about 0.3 to 0.5N·m, and M3 screws with a torque of about 0.5 to 0.7N·m.

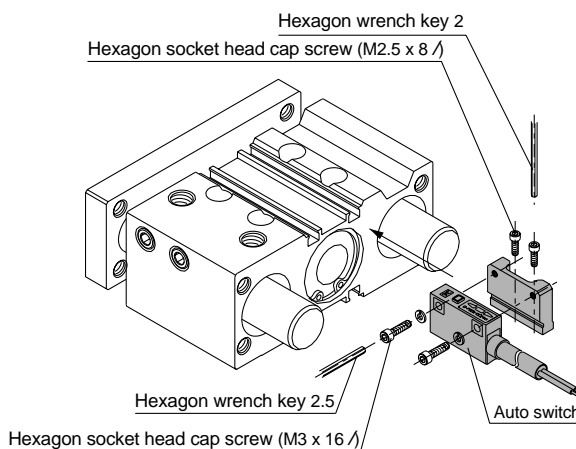

Standard Type
MGP

With Air Cushion
MGP

With End Lock
MGP

Heavy Duty
Guide Rod Type
MGPS

Order Made
Specifications

Auto Switches

Precautions

Series MGPS

Construction

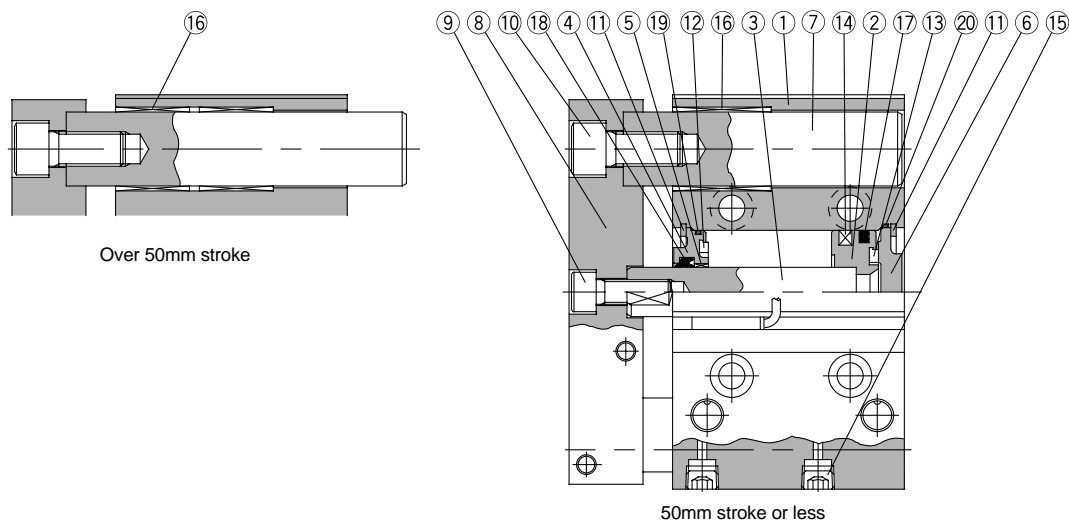

Parts list

No.	Description	Material	Note
1	Body	Aluminum alloy	Hard anodized
2	Piston	Aluminum alloy	Chromated
3	Piston rod	Carbon steel	Hard chrome plated
4	Collar	Aluminum alloy casting	Coated
5	Bushing	Lead bronze casting	
6	Head cover	Aluminum alloy	ø50 Colorless chromated
			ø80 Coated
7	Guide rod	Carbon steel	Hard chrome plated
8	Plate	Carbon steel	Nickel plated
9	Plate mounting bolt A	Carbon steel	Nickel plated For piston rod
10	Plate mounting bolt B	Carbon steel	Nickel plated For guide rod

Parts list

No.	Description	Material	Note
11	Snap ring	Carbon tool steel	Phosphate coated
12	Bumper A	Urethane	
13	Bumper B	Urethane	
14	Magnet	Synthetic rubber	
15	Hexagon socket head taper plug	Carbon steel	Nickel plated
16	Slide bearing	Lead bronze casting	
17*	Piston seal	NBR	
18*	Rod seal	NBR	
19*	Gasket A	NBR	
20*	Gasket B	NBR	

Replacement parts: Seal kits

Bore size (mm)	Kit no.	Contents
50	MGP50-PS	Kits include items 17, 18, 19 and 20 from the table above.
80	MGP80-PS	

* Seal kits are sets consisting of items 17 through 20 above, and can be ordered using the kit number for each bore size.

Dimensions

MGPS50/80

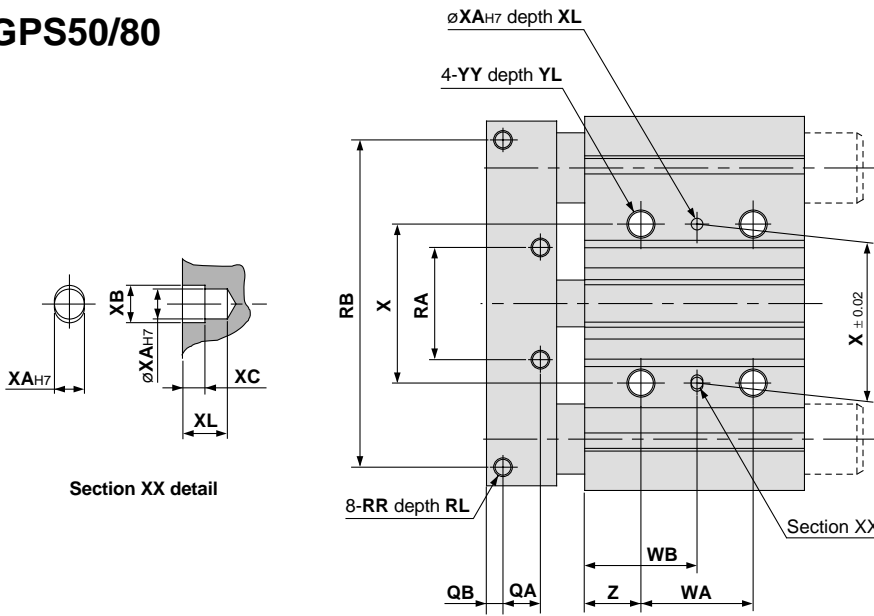

T-slot dimensions

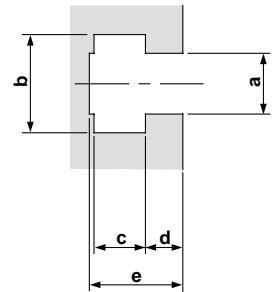

Bore size (mm)	T-slot dimensions				
	a	b	c	d	e
50	11	17.8	10	6	17.5
80	13.3	20.3	12	8	22.5

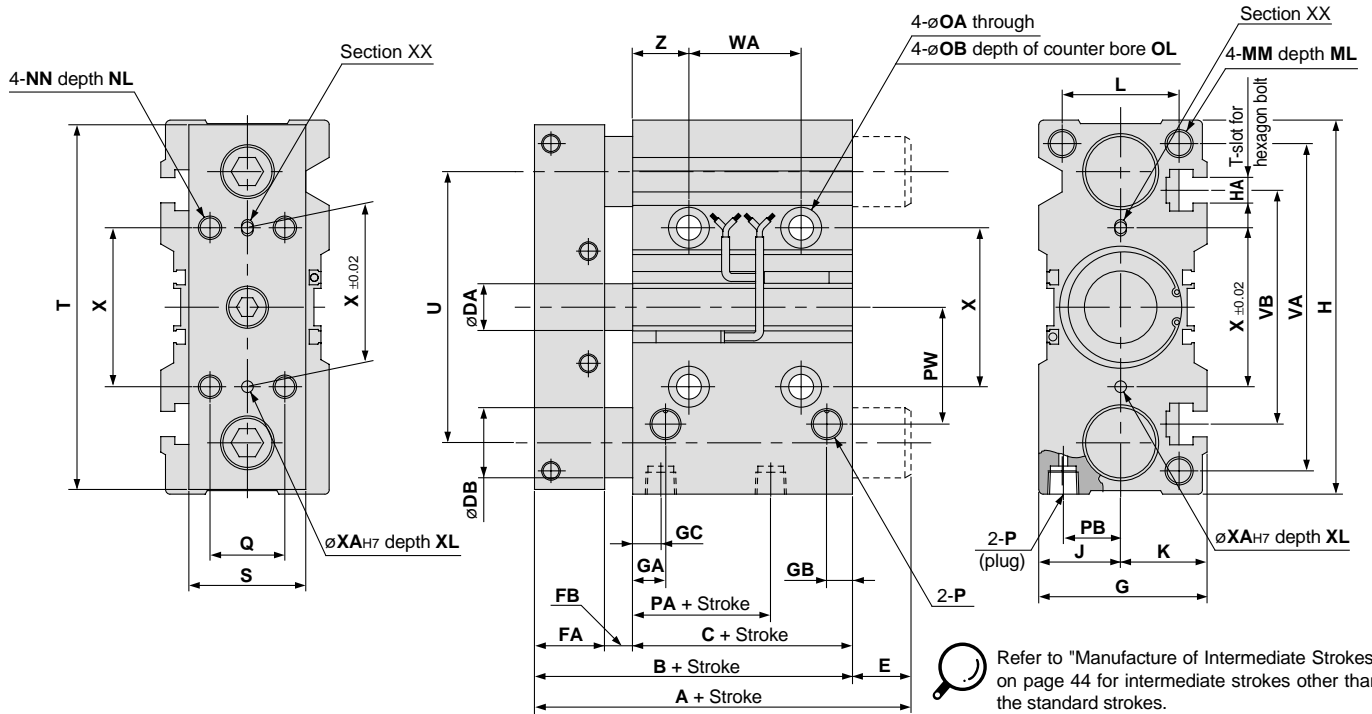

Refer to "Manufacture of Intermediate Strokes" on page 44 for intermediate strokes other than the standard strokes.

Dimensions

Bore size (mm)	Standard stroke (mm)	A		B	C	DA	DB	E		FA	FB	G	GA	GB	GC	H	HA	J	K	L
		25, 50st	Over 50st					25, 50st	Over 50st											
50	25, 50, 75, 100,	86	110	86	44	20	30	0	24	30	12	72	14	11	12	160	M10	35	37	50
80	125, 150, 175, 200	118	151	118	65	25	45	0	33	35	18	95	19	24	14.5	242	M12	47	48	66

Bore size (mm)	Standard stroke (mm)	MM	ML	NN	NL	OA	OB	OL	P	PA	PB	PW	Q	QA	QB	RA	RB	RR	RL
		50	25, 50, 75, 100,	M12 x 1.75	20	M10 x 1.5	20	10.6	17.5	13	Rc 1/4	9	24.5	50	32	16	7	48	140
80	125, 150, 175, 200	M16 x 2	32	M12 x 1.75	24	12.5	20	17.5	Rc 3/8	14.5	29	77	40	18	9	80	200	M10 x 1.5	20

Bore size (mm)	Standard stroke (mm)	S	T	U	VA	VB	WA			WB			X	XA	XB	XC	XL
							25st	50, 75, 100st	Over 100st	25st	50, 75, 100st	Over 100st					
50	25, 50, 75, 100,	50	156	116	140	100	24	48	124	36	48	86	68	5	6	4	8
80	125, 150, 175, 200	65	228	170	214	138	28	52	128	42	54	92	100	6	7	5	10

Bore size (mm)	Standard stroke (mm)	YY	YL	Z
		50	25, 50, 75, 100,	M12 x 1.75
80	125, 150, 175, 200	M14 x 2	28	28

Series MGP Order Made Specifications

Contact SMC for detailed specifications and lead times, and for applications of cylinders with air cushion, heavy duty guide rod type, and lock type.

Order made specification		Symbol
①	Intermediate stroke (special body type)	-XB10
②	With air cushion/Intermediate stroke (spacer installed type)	-XC19
③	Heat resistant cylinder	-XB6
④	Low speed cylinder	-XB13
⑤	Fluoro rubber seal	-XC22

Order made specification		Symbol
⑥	With heavy duty scraper	-XC4
⑦	With coil scraper	-XC35
⑧	Adjustable stroke cylinder/Adjustable extension type	-XC8
⑨	Adjustable stroke cylinder/Adjustable retraction type	-XC9
⑩	Stainless steel used for piston rod, plate, etc.	-XC6

① Intermediate Strokes (Special Body Type)

-XB10

MGP^M_L Bore size - Stroke - XB10
Intermediate stroke ●

When using an intermediate stroke, the overall length of the cylinder can be shortened by using a special body without the installation of spacers.

Stroke ranges

Bore size (mm)	Stroke range (mm)
12, 16	10 to 250
20, 25	20 to 400
32, 40, 50, 63, 80, 100	25 to 400

* Specifications other than the stroke range are the same as standard products.

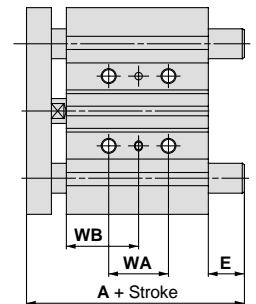

Dimensions

MGPM, MGPL-XB10/Dimensions WA, WB

(mm)

Bore size (mm)	Standard stroke (mm)	WA				WB			
		10 to 39st	40 to 100st	101 to 200st	201 to 250st	10 to 39st	40 to 100st	101 to 200st	201 to 250st
12	10 to 250	20	40	110	200	15	25	60	105
16		24	44	110	200	17	27	60	105

Bore size (mm)	Standard stroke (mm)	WA					WB				
		20 to 39st	40 to 124st	125 to 200st	201 to 300st	301 to 400st	20 to 39st	40 to 124st	125 to 200st	201 to 300st	301 to 400st
20	20 to 400	24	44	120	200	300	29	39	77	117	167
25		24	44	120	200	300	29	39	77	117	167

Bore size (mm)	Standard stroke (mm)	WA					WB				
		25 to 49st	50 to 124st	125 to 200st	201 to 300st	301 to 400st	25 to 49st	50 to 124st	125 to 200st	201 to 300st	301 to 400st
32	25 to 400	24	48	124	200	300	33	45	83	121	171
40		24	48	124	200	300	34	46	84	122	172
50		24	48	124	200	300	36	48	86	124	174
63		28	52	128	200	300	38	50	88	124	174
80		28	52	128	200	300	42	54	92	128	178
100		48	72	148	220	320	35	47	85	121	171

MGPM (slide bearing)/Dimensions A, E

(mm)

Bore size (mm)	A			E		
	10 to 74st	75 to 100st	101 to 250st	10 to 74st	75 to 100st	101 to 250st
12	42	60.5	85	0	18.5	43
16	46	64.5	95	0	18.5	49

Bore size (mm)	A			E		
	20 to 74st	75 to 200st	201 to 400st	20 to 74st	75 to 200st	201 to 400st
20	53	84.5	122	0	31.5	69
25	53.5	85	122	0	31.5	68.5

Bore size (mm)	A			E		
	25 to 74st	75 to 200st	201 to 400st	25 to 74st	75 to 200st	201 to 400st
32	97	102	140	37.5	42.5	80.5
40	97	102	140	31	36	74
50	106.5	118	161	34.5	46	89
63	106.5	118	161	29.5	41	84
80	115	142	193	18.5	45.5	96.5
100	137	162	203	21	46	87

* Dimensions other than those in the above tables are the same as standard products.

MGPL (ball bushing)/Dimensions A, E

(mm)

Bore size (mm)	A			E		
	10 to 39st	40 to 100st	101 to 250st	10 to 39st	40 to 100st	101 to 250st
12	43	55	85	1	13	43
16	49	65	95	3	19	49

Bore size (mm)	A				E			
	20 to 39st	40 to 124st	125 to 200st	201 to 400st	20 to 39st	40 to 124st	125 to 200st	201 to 400st
20	63	80	104	122	10	27	51	69
25	69.5	85.5	104.5	122	16	32	51	68.5

Bore size (mm)	A				E			
	25 to 74st	75 to 124st	125 to 200st	201 to 400st	25 to 74st	75 to 124st	125 to 200st	201 to 400st
32	81	98	118	140	21.5	38.5	58.5	80.5
40	81	98	118	140	15	32	52	74
50	93	114	134	161	21	42	62	89
63	93	114	134	161	16	37	57	84

Bore size (mm)	A				E			
	25 to 49st	50 to 74st	75 to 200st	201 to 400st	25 to 49st	50 to 74st	75 to 200st	201 to 400st
80	109.5	130	160	193	13	33.5	63.5	96.5
100	121	147	180	203	5	31	64	87

Series MGP Order Made Specifications

Contact SMC for detailed specifications and lead times, and for applications of cylinders with air cushion, heavy duty guide rod type, and lock type.

② With Air Cushion/Intermediate Strokes (Spacer Installed Type)

-XC19

MGP^M_L Bore size — Stroke A — XC19

With air cushion/intermediate stroke ●

The collar of of the standard stroke cylinder is changed to accommodate intermediate strokes in 1mm increments.

(Intermediate strokes (in 1mm increments) with a special body are available by special order.)

Bore size (mm)	Stroke range (mm)
ø16	26 to 99
ø20 to ø63	26 to 199
ø80, ø100	51 to 199

* Specifications and dimensions are the same as the standard products with air cushion.

③ Heat Resistant Cylinder

-XB6

MGPM Bore size — Stroke — XB6

Heat resistant cylinder ●

Cylinder with modified seal and grease materials to make possible high temperature operation up to an ambient temperature of 150°C.

Specifications

Applicable series	MGPM
Bearing type	Slide bearing
Cylinder bore size (mm)	12, 16, 20, 25, 32, 40, 50, 63, 80, 100
Ambient temperature range	-10 to 150°C
Seal material	Fluoro rubber
Grease	Heat resistant grease
Cushion	None
Auto switch	Not applicable

* 1. Dimensions are the same as standard products.
* 2. Refer to page 56 for allowable kinetic energy.

④ Low Speed Cylinder

-XB13

MGP^M_L Bore size — Stroke — XB13

Low speed cylinder ●

Operates smoothly, without sticking and slipping, at drive speeds as low as 5 to 50mm/s.

Specifications

Applicable series	MGPM, MGPL
Bearing type	Slide bearing, Ball bushing
Cylinder bore size (mm)	12, 16, 20, 25, 32, 40, 50, 63, 80, 100
Piston speed	5 to 50mm/s
Cushion	Rubber bumper

* Dimensions are the same as standard products.

⑤ Fluoro Rubber Seals

-XC22

MGPM Bore size — Stroke — XC22

Fluoro rubber seals ●

Seals are changed to a fluoro rubber material which has outstanding resistance to chemicals.

Specifications

Applicable series	MGPM
Bearing type	Slide bearing
Cylinder bore size (mm)	12, 16, 20, 25, 32, 40, 50, 63, 80, 100
Cushion	None
Auto switch	Mountable

* 1. Dimensions are the same as standard products.
* 2. Refer to page 56 for allowable kinetic energy.

Standard Type
MGP

With Air Cushion
MGP

With End Lock
MGP

Heavy Duty
Guide Rod Type
MGPS

Order Made
Specifications

Auto Switches

Precautions

Series MGP Order Made Specifications

Contact SMC for detailed specifications and lead times, and for applications of cylinders with air cushion, heavy duty guide rod type, and lock type.

6 With Heavy Duty Scraper

-XC4

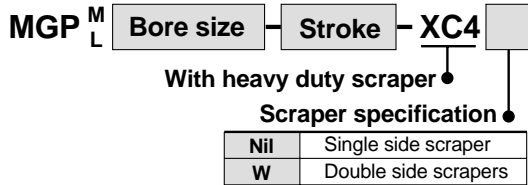

With a heavy duty scraper used for the piston rod and guide rod sections, this specification is ideal for cylinders used in a dusty environment, or in environments where there is contact with earth and sand, such as molding machines, construction equipment, and industrial vehicles, etc. Furthermore, depending on the mounting orientation, the scraper on the plate side only (–XC4) or the double side scraper (–XC4W) can be selected.

Specifications

Applicable series		MGPM, MGPL
Bearing type		Slide bearing, Ball bushing
Cylinder bore size (mm)		20, 25, 32, 40, 50, 63, 80, 100
Minimum operating pressure	Single side	0.12MPa
	Double side	0.14MPa

* Refer to the tables below for dimensions.

7 With Coil Scraper

-XC35

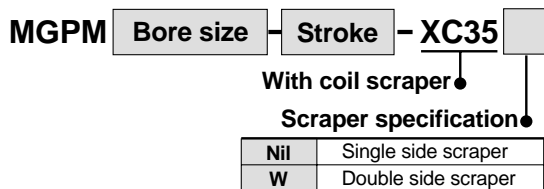

Removes frost, welding spatter, and machining chips from the piston rod and the guide rod, and protects the seals. Furthermore, depending on the mounting orientation, the scraper on the plate side only (–XC35) or the double side scraper (–XC35W) can be selected.

Specifications

Applicable series		MGPM
Bearing type		Slide bearing
Cylinder bore size (mm)		20, 25, 32, 40, 50, 63, 80, 100
Minimum operating pressure	Single side	0.12MPa
	Double side	0.14MPa

* Refer to the tables below for dimensions.

With Heavy Duty Scraper/With Coil Scraper Common Dimensions

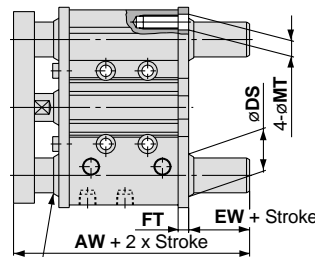
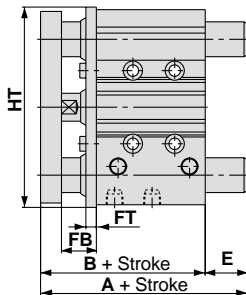

The figure shows the heavy duty scraper (–XC4).
Cylinders with coil scraper (–XC35) are without this lip.

For cylinder with double side scraper

MGPM, MGPL

Common dimensions (mm)

Bore size (mm)	B	FB	FT
20	63	16	5
25	63.5	16	5
32	69.5	20	6
40	76	20	6
50	82	22	6
63	87	22	6
80	106.5	28	6
100	126	35	9

With double side scrapers

Dimensions AW, EW, MT, DS (mm)

Bore size (mm)	AW	EW	MT	DS *	
				MGPM	MGPL
20	74	6	6	17	15
25	74.5	6	7	21	19
32	82.5	7	8.5	26	21
40	89	7	9	26	21
50	95	7	11	31	26
63	100	7	11	31	26
80	120.5	8	14	36	31
100	143	8	16	44	36

* By-pass port size for guide rod with bottom mount

MGPM (slide bearing)/Dimensions A, E, HT (mm)

Bore size (mm)	A			E			HT	
	50st or less	Over 50st to 200st	Over 200st	50st or less	Over 50st to 200st	Over 200st	XC4	XC35
20	63	94.5	132	0	31.5	69	80	80
25	63.5	95	132	0	31.5	68.5	93	93
32	97	112	150	27.5	42.5	80.5	113	110
40	97	112	150	21	36	74	121	118
50	106.5	128	171	24.5	46	89	153	146
63	106.5	128	171	19.5	41	84	167	160
80	125	152	203	18.5	45.5	96.5	205	200
100	147	172	213	21	46	87	244	238

MGPL (ball bushing)/Dimensions A, E, HT (mm)

Bore size (mm)	A				E				HT
	30st or less	Over 30st to 100st	Over 100st to 200st	Over 200st	30st or less	Over 30st to 100st	Over 100st to 200st	Over 200st	
20	73	90	114	132	10	27	51	69	80
25	79.5	95.5	114.5	132	16	32	51	68.5	93

Bore size (mm)	A				E				HT
	50st or less	Over 50st to 100st	Over 100st to 200st	Over 200st	50st or less	Over 50st to 100st	Over 100st to 200st	Over 200st	
32	91	108	128	150	21.5	38.5	58.5	80.5	110
40	91	108	128	150	15	32	52	74	118
50	103	124	144	171	21	42	62	89	146
63	103	124	144	171	16	37	57	84	160

Bore size (mm)	A				E				HT
	25st or less	Over 25st to 50st	Over 50st to 100st	Over 100st to 200st	25st or less	Over 25st to 50st	Over 50st to 100st	Over 100st to 200st	
80	119.5	140	170	203	13	33.5	63.5	96.5	201
100	131	157	190	213	5	31	64	87	238

Series MGP Order Made Specifications

Contact SMC for detailed specifications and lead times, and for applications of cylinders with air cushion, heavy duty guide rod type, and lock type.

Standard Type
MGP

With Air Cushion
MGP

With End Lock
MGP

Heavy Duty
Guide Rod Type
MGPS

Order Made
Specifications

Auto Switches

Precautions

8 Adjustable Stroke Cylinder/Adjustable Extension Type

-XC8

MGP ^M/_L Bore size — Stroke A — XC8

Stroke adjustment ●

A	10mm adjustment
B	25mm adjustment

Adjustable stroke cylinder
Adjustable extension type ●

The extended stroke of the cylinder can be adjusted 0 to 10mm or 0 to 25mm from the full stroke.
Install a stroke adjustment mechanism at the head side to adjust the extended stroke.

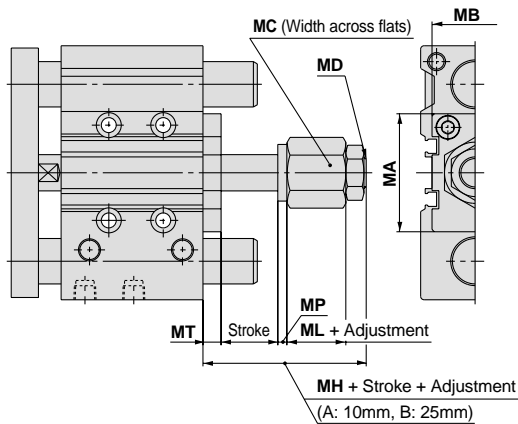

Specifications

Applicable series	MGPM, MGPL	
Bearing type	Slide bearing, Ball bushing	
Cylinder bore size (mm)	12, 16, 20, 25, 32, 40, 50, 63, 80, 100	
Piston speed	ø12 to ø32	50 to 300mm/s
	ø40 to ø100	50 to 400mm/s
Stroke adjustment	A	10mm
	B	25mm

MGPM, MGPL Common dimensions (mm)

Bore size (mm)	MA	MB	MC	MD	MH	ML	MP	MT
12	28	16	14	M5 x 0.8	22	9	3	5
16	29	19	14	M5 x 0.8	22	9	3	5
20	34	30	22	M8 x 1.25	30	12.5	3	8
25	40	30	22	M8 x 1.25	30	12.5	3	8
32	52	38	27	M14 x 1.5	37	16	4	8
40	60	38	27	M14 x 1.5	37	16	4	8
50	68	50	36	M18 x 1.5	47	20	4	9
63	84	50	36	M18 x 1.5	47	20	4	9
80	114	50	46	M22 x 1.5	58	28	4	12
100	140	65	46	M22 x 1.5	62	28	4	16

9 Adjustable Stroke Cylinder/Adjustable Retraction Type

-XC9

MGP ^M/_L Bore size — Stroke A — XC9

Stroke adjustment ●

A	10mm adjustment
B	25mm adjustment

Adjustable stroke cylinder
Adjustable retraction type ●

With an adjustment bolt, the retracted stroke of the cylinder can be adjusted 0 to 10mm or 0 to 25mm from the full stroke. (After the stroke adjustment, only the rod side is equipped with a rubber bumper.)

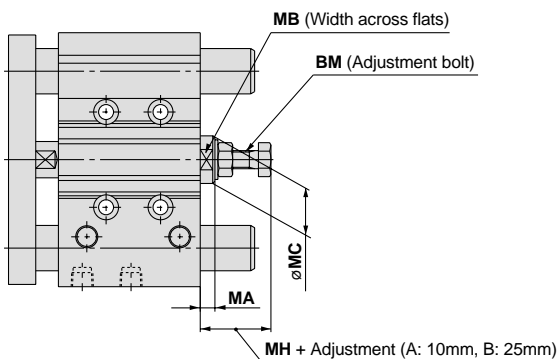

Specifications

Applicable series	MGPM, MGPL	
Bearing type	Slide bearing, Ball bushing	
Cylinder bore size (mm)	12, 16, 20, 25, 32, 40, 50, 63, 80, 100	
Piston speed	ø12 to ø32	50 to 300mm/s
	ø40 to ø100	50 to 400mm/s
Cushion	Rod side	Rubber bumper
	Head side	None
Stroke adjustment	A	10mm
	B	25mm

* Refer to page 56 for the allowable kinetic energy on the retracted side.

MGPM, MGPL Common dimensions (mm)

Bore size (mm)	BM	MA	MB	MC	MH
12	M5 x 0.8	5	8	12.5	19
16	M6 x 1.0	5	10	11.5	19
20	M8 x 1.25	6.5	13	16	27
25	M8 x 1.25	6.5	13	16	26.5
32	M8 x 1.25	6.5	19	21	26.5
40	M12 x 1.5	9	27	30	33
50	M12 x 1.5	9	30	34	32.5
63	M16 x 1.5	10	36	40	37
80	M20 x 1.5	15	41	46	53.5
100	M24 x 1.5	18	46	52	57.5

Series MGP Order Made Specifications

Contact SMC for detailed specifications and lead times, and for applications of cylinders with air cushion, heavy duty guide rod type, and lock type.

10 Stainless Steel Piston Rod, Plate, etc.

-XC6

MGP ^M _L Bore size - Stroke - XC6 A

Stainless steel material ●

Stainless steel specification ●

A	Stainless steel parts
B	Stainless steel rod parts

The materials used for some of the standard product parts are modified to stainless steel.

	Stainless steel modified parts
XC6A	1, 2, 3, 4, 5, 6
XC6B	1, 2, 5, 6

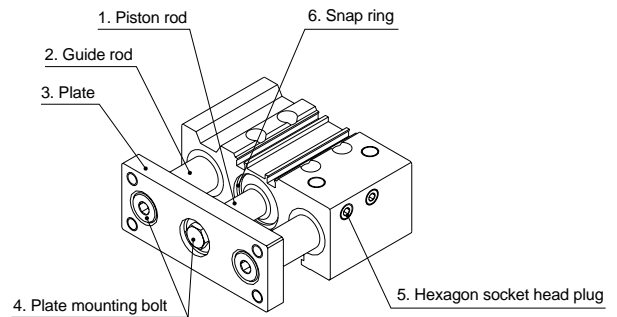

⚠ Allowable Kinetic Energy for Order Made Specifications (without Bumper)

Some of the order made specification cylinders have a construction without internal bumpers. For the following order made products, refer to the graph for their overall load weight (load weight + weight of the moving parts of the cylinder) and piston speed at the stroke end.

Applicable order made products:

- Heat resistant cylinder (-XB6)
- Adjustable stroke cylinder/Adjustable retraction type (-XC9)
- Fluoro rubber seals (-XC22)

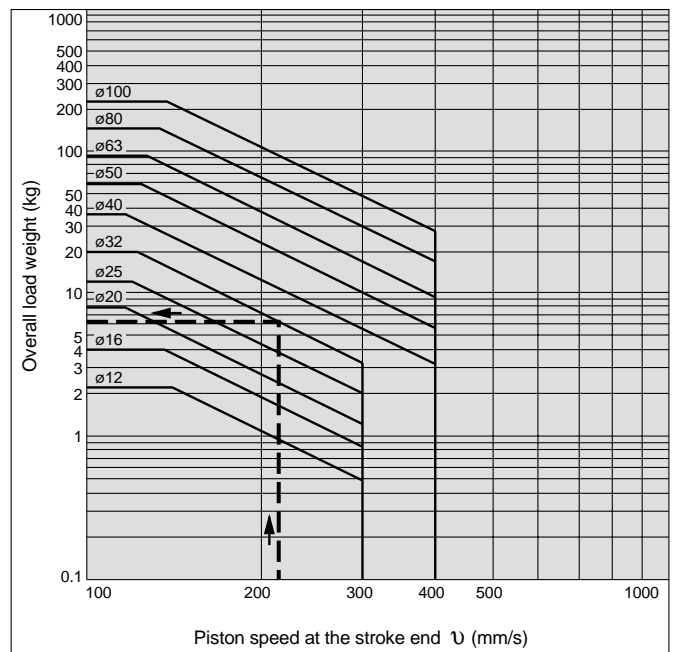

Series MGP

Auto Switch Common Specifications

Auto Switch Common Specifications

Type	Reed switch	Solid state switch
Leakage current	None	3 wire: 100μA or less, 2 wire: 0.8mA or less
Operating time	1.2ms	1ms or less
Impact resistance	300m/s ²	1000m/s ²
Insulation resistance	50MΩ or more at 500VDC (between lead wire and case)	
Withstand voltage	1500VAC for 1 min. (between lead wire and case)	1000VAC for 1 min. (between lead wire and case)
Ambient temperature	-10 to 60°C	
Enclosure	IEC529 standard IP67, JISC0920 watertight construction	

Lead Wire Length

Lead wire length indication

(Example)

D-Z73 L

Lead wire length

Nil	0.5m
L	3m
Z	5m

Note 1) Lead wire length Z: 5m applicable auto switch
 Reed: D-Z73
 Solid state: All types are produced upon receipt of order (standard availability).

Auto Switch Hysteresis

Hysteresis is the distance from the position at which piston movement activates an auto switch to the position at which reverse movement turns the switch OFF. This hysteresis is included in part of the operating range (one side).

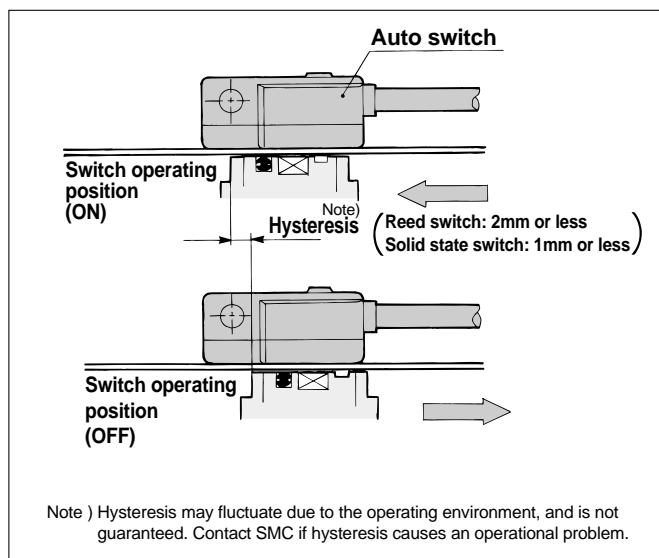

Contact Protection Boxes/CD-P11, CD-P12

D-Z7 and D-Z8 type switches do not have internal contact protection circuits.

1. The operating load is an induction load.
2. The length of wiring to the load is 5m or more.
3. The load voltage is 100VAC.

A contact protection box should be used in any of the above situations.

Contact protection box specifications

Part no.	CD-P11		CD-P12
Load voltage	100VAC or less	200VAC	24VDC
Maximum load current	25mA	12.5mA	50mA

* Lead wire length Switch connection side 0.5m
 Load connection side 0.5m



Contact protection box internal circuits
 Lead wire colors inside [] are those prior to conformity with IEC standards.

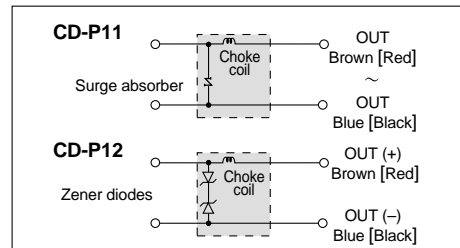

Contact protection box dimensions

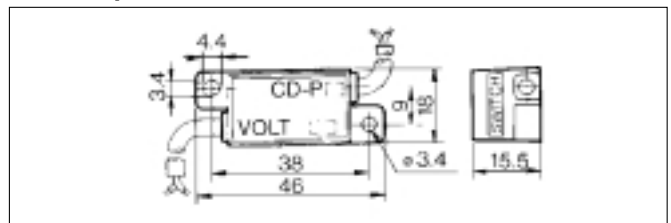

Contact Protection Box Connection

To connect a switch unit to a contact protection box, connect the lead wire from the side of the contact protection box marked SWITCH to the lead wire coming out of the switch unit.

Furthermore, the switch unit should be kept as close as possible to the contact protection box, with a lead wire length of no more than 1 meter between them.

Series MGP Auto Switch Connections and Examples

Basic Wiring

Lead wire colors inside [] are those prior to conformity with IEC standards.

Solid state 3 wire, NPN

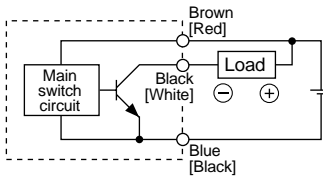

(Power supplies for switch and load are separate.)

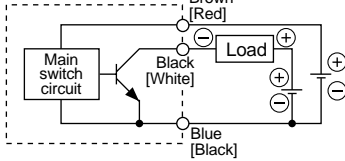

Solid state 3 wire, PNP

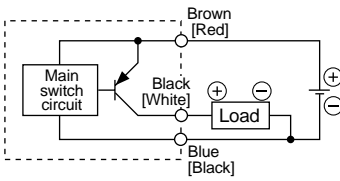

2 wire <Solid state>

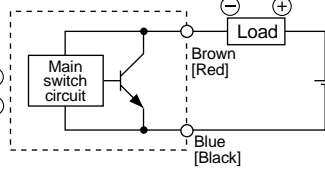

2 wire <Reed switch>

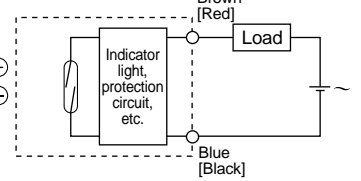

Examples of Connection to PLC

Sink input specifications

3 wire, NPN

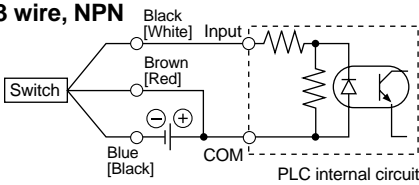

2 wire

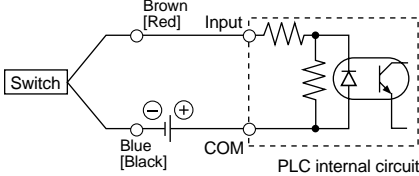

Source input specifications

3 wire, PNP

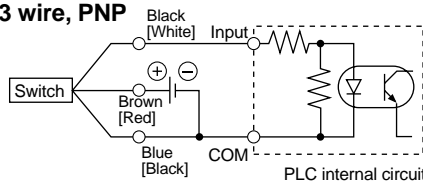

2 wire

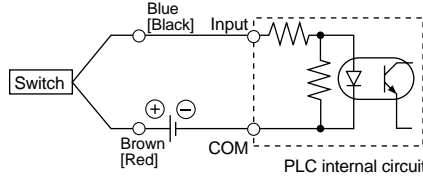

Connect according to the applicable PLC input specifications, as the connection method will vary depending on the PLC input specifications.

Connection Examples for AND (Series) and OR (Parallel)

3 wire

AND connection for NPN output (using relays)

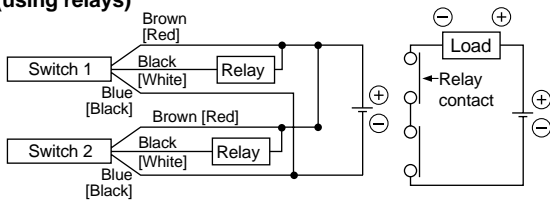

AND connection for NPN output (performed with switches only)

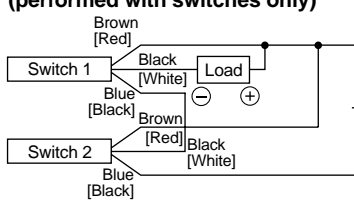

OR connection for NPN output

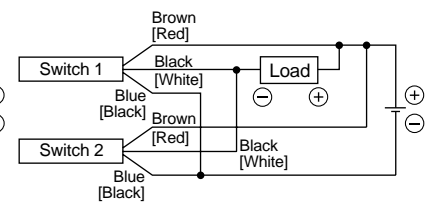

The indicator lights will light up when both switches are turned ON.

2 wire with 2 switch AND connection

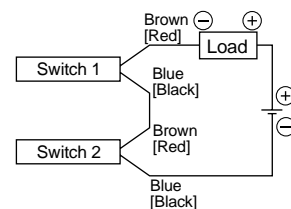

When two switches are connected in series, a load may malfunction because the load voltage will decline when in the ON state. The indicator lights will light up if both of the switches are in the ON state.

$$\begin{aligned} \text{Load voltage at ON} &= \text{Power supply voltage} - \text{Internal voltage drop} \times 2 \text{ pcs.} \\ &= 24\text{V} - 4\text{V} \times 2 \text{ pcs.} \\ &= 16\text{V} \end{aligned}$$

Example: Power supply is 24VDC
Internal voltage drop in switch is 4V

2 wire with 2 switch OR connection

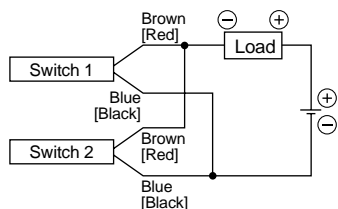

<Solid state>

When two switches are connected in parallel, malfunction may occur because the load voltage will increase when in the OFF state.

<Reed switch>

Because there is no current leakage, the load voltage will not increase when turned OFF. However, depending on the number of switches in the ON state, the indicator lights may sometimes dim or not light up, because of dispersion and reduction of the current flowing to the switches.

$$\begin{aligned} \text{Load voltage at OFF} &= \text{Leakage current} \times 2 \text{ pcs.} \times \text{Load impedance} \\ &= 1\text{mA} \times 2 \text{ pcs.} \times 3\text{k}\Omega \\ &= 6\text{V} \end{aligned}$$

Example: Load impedance is 3kΩ
Leakage current from switch is 1mA

Reed Switches/Direct Mount Type D-Z73/Z76/Z80



Internal circuits

Lead wire colors inside [] are those prior to conformity with IEC standards.

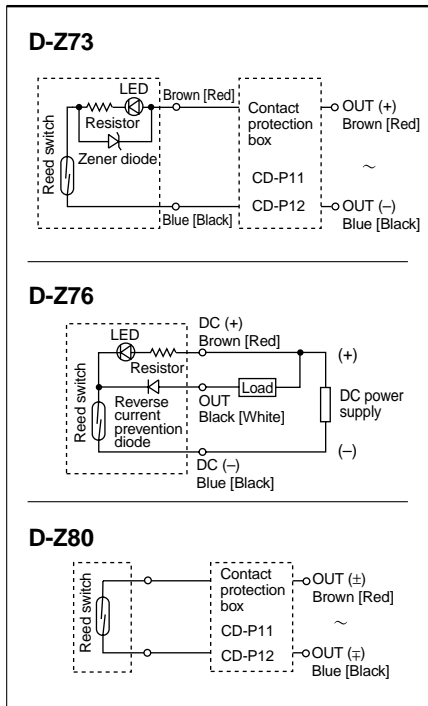

Note) 1. The load is an induction load.
2. The lead wire length to the load is 5m or more.
3. The load voltage is 100VAC.
Use a contact protection box in any of the above situations, as the life of the contacts may otherwise be reduced. (Refer to page 57 for detailed specifications of the contact protection boxes.)

Auto Switch Specifications

With indicator light

Auto switch part no.	D-Z73		D-Z76
Electrical entry direction	In-line		
Applicable load	Relay, PLC		IC circuit
Load voltage	24VDC	100VAC	4 to 8VDC
Maximum load current or current range	5 to 40mA	5 to 20mA	20mA
Contact protection circuit	None		
Internal voltage drop	2.4V or less (to 20mA)/3V or less (to 40mA)		0.8V or less
Indicator light	Red LED lights up when ON		

Without indicator light

Auto switch part no.	D-Z80		
Electrical entry direction	In-line		
Applicable load	Relay, PLC, IC circuit		
Load voltage	24V ^{AC} _{DC} or less	48V ^{AC} _{DC}	100V ^{AC} _{DC}
Maximum load current	50mA	40mA	20mA
Contact protection circuit	None		
Internal resistance	1Ω or less (including lead wire length of 3m)		

• Lead wire — Oil resistant heavy duty vinyl cord, ø3.4, 0.2mm², 2 wire (Brown, Blue [Red, Black]), 3 wire (Brown, Black, Blue [Red, White, Black]), 0.5m (D-Z73 only ø2.7, 0.18mm², 2 wire)

Note) Refer to page 57 for auto switch common specifications and lead wire lengths.

Weights

Model	Unit: g	
	Lead wire length 0.5m	Lead wire length 3m
D-Z73	9	49
D-Z76	10	55
D-Z80	9	49

Dimensions

D-Z73

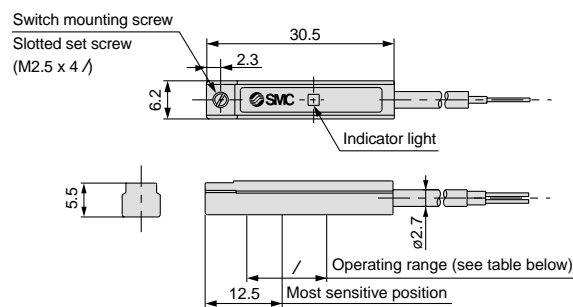

D-Z76, Z80

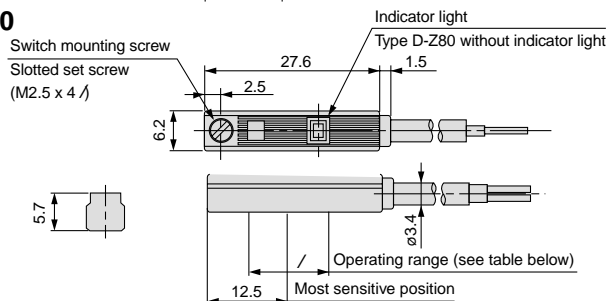

Bore size	Bore size (mm)									
	12	16	20	25	32	40	50	63	80	100
Operating range	7.5	10	10	10	10.5	10.5	10.5	11.5	11.5	12
Operating range / (mm)										

Note) This is a standard including hysteresis, and is not guaranteed. There may be large variations depending on the surrounding environment (variations on the order of ±30%).

Solid State Switches/Direct Mount Type D-Y59^A/_B/D-Y69^A/_B/D-Y7P(V)



Auto Switch Specifications

D-Y5, D-Y6, D-Y7P, D-Y7PV (with indicator light)

Auto switch part no.	D-Y59A	D-Y69A	D-Y7P	D-Y7PV	D-Y59B	D-Y69B
Electrical entry direction	In-line	Perpendicular	In-line	Perpendicular	In-line	Perpendicular
Wiring type	3 wire				2 wire	
Output type	NPN		PNP		-	
Applicable load	IC circuit, Relay, PLC				24VDC Relay, PLC	
Power supply voltage	5, 12, 24VDC (4.5 to 28VDC)				-	
Current consumption	10mA or less				-	
Load voltage	28VDC or less		-		24VDC (10 to 28VDC)	
Load current	40mA or less		80mA or less		5 to 40mA	
Internal voltage drop	1.5V or less (0.8V or less at 10mA load current)		0.8V or less		4V or less	
Leakage current	100μA or less at 24VDC				0.8mA or less at 24VDC	
Indicator light	Red LED lights up when ON					

• Lead wire — Oil resistant, flexible heavy duty vinyl cord, $\phi 3.4$, 0.15mm², 2 wire (Brown, Blue [Red, Black]),
3 wire (Brown, Black, Blue [Red, White, Black]), 0.5m

Note) Refer to page 57 for auto switch common specifications and lead wire lengths.

Weights

Unit: g

Model	Lead wire length	
	0.5m	3m
D-Y59A, Y69A, Y7P	10	53
D-Y59B, Y69B, Y7PV	9	50

Internal circuits

Lead wire colors inside [] are those prior to conformity with IEC standards.

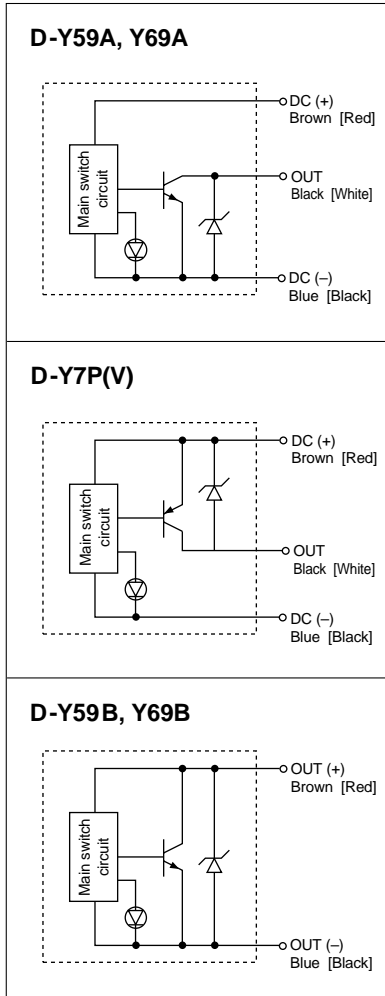

Dimensions

D-Y59A, Y59B D-Y7P

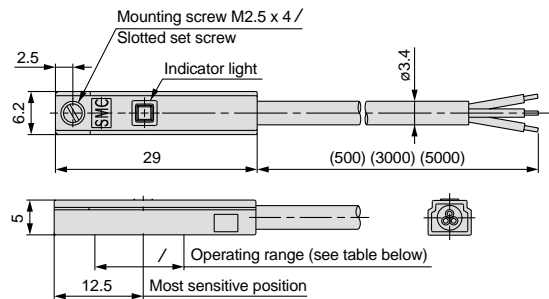

D-Y69A, Y69B D-Y7PV

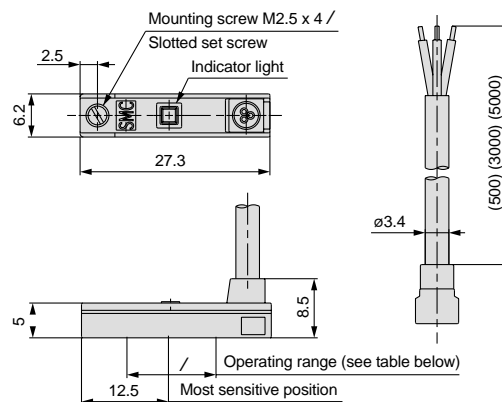

Operating range	Bore size (mm)									
	12	16	20	25	32	40	50	63	80	100
Operating range / (mm)	5.5	7.5	7.5	7	6.5	6	7	8	9.5	10

Note) This is a standard including hysteresis, and is not guaranteed. There may be large variations depending on the surrounding environment (variations on the order of $\pm 30\%$).

2 Color Indication Solid State Switches Direct Mount Type D-Y7NW(V)/Y7PW(V)/D-Y7BW(V)



Internal circuits

Lead wire colors inside [] are those prior to conformity with IEC standards.

D-Y7NW(V)/3 wire NPN output

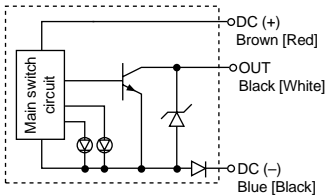

D-Y7PW(V)/3 wire PNP output

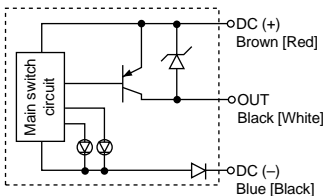

D-Y7BW(V)/2 wire

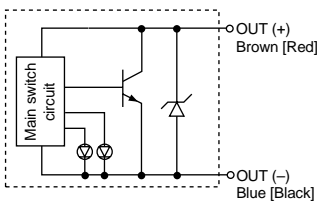

Indicator light/Display method

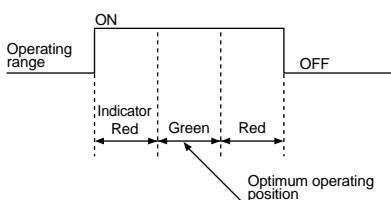

Auto Switch Specifications

D-Y7□W, D-Y7□WV (with indicator light)

Auto switch part no.	D-Y7NW	D-Y7NWV	D-Y7PW	D-Y7PWV	D-Y7BW	D-Y7BWV
Electrical entry direction	In-line	Perpendicular	In-line	Perpendicular	In-line	Perpendicular
Wiring type	3 wire			2 wire		
Output type	NPN		PNP		-	
Applicable load	IC circuit, Relay, PLC				24VDC relay, PLC	
Power supply voltage	5, 12, 24VDC (4.5 to 28VDC)					
Current consumption	10mA or less					
Load voltage	28VDC or less		-		24VDC (10 to 28VDC)	
Load current	40mA or less		80mA or less		5 to 40mA	
Internal voltage drop	1.5V or less (0.8V or less at 10mA load current)		0.8V or less		4V or less	
Leakage current	100μA or less at 24VDC				0.8mA or less at 24VDC	
Indicator light	Actuated position Red LED lights up Optimum operating position Green LED lights up					

- Lead wire — Oil resistant, flexible heavy duty vinyl cord, $\phi 3.4$, 0.15mm², 3 wire (Brown, Black, Blue [Red, White, Black]), 2 wire (Brown, Blue [Red, Black]), 0.5m
Note) Refer to page 57 for auto switch common specifications and lead wire lengths.

Weights

Model	Lead wire length	
	0.5m	3m
D-Y7N, Y7P	10	53
D-Y7B	9	50

Unit: g

Dimensions

D-Y7□W

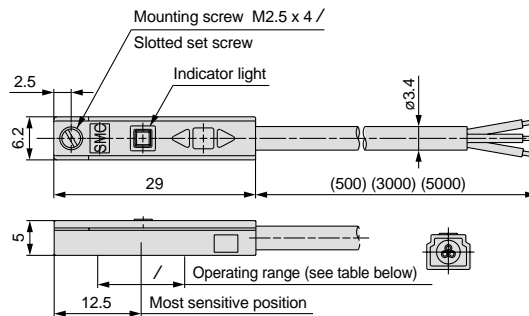

D-Y7□WV

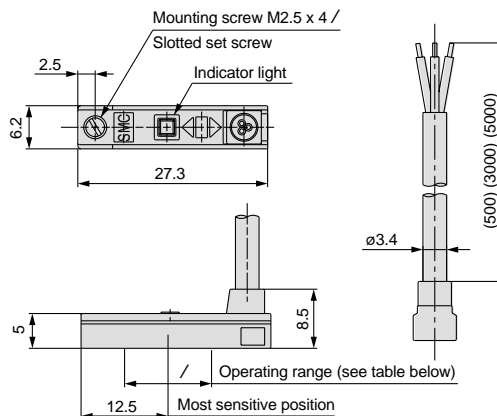

Operating range	Bore size (mm)									
	12	16	20	25	32	40	50	63	80	100
Operating range / (mm)	5.5	7.5	7.5	7	6.5	6	7	8	9.5	10

Note) This is a standard including hysteresis, and is not guaranteed. There may be large variations depending on the surrounding environment (variations on the order of $\pm 30\%$).

Water Resistant 2 Color Indication Solid State Switches/Direct Mount Type D-Y7BAL

Water (coolant) resistant type



Auto Switch Specifications

D-Y7BAL (with indicator light)

Auto switch model no.	D-Y7BAL
Electrical entry direction	In-line
Wiring type	2 wire
Applicable load	24VDC relay, PLC
Load voltage	24VDC (10 to 28VDC)
Load current	5 to 40mA
Internal voltage drop	4V or less
Leakage current	1mA or less at 24VDC
Indicator light	Actuated position Red LED lights up Optimum operating position Green LED lights up

• Lead wire — Oil resistant, flexible heavy duty vinyl cord, $\phi 3.4$, 0.15mm²; 2 wire (Brown, Blue [Red, Black]), 3m
Note) Refer to page 57 for auto switch common specifications and lead wire lengths.

Operating Precautions

⚠ Caution

1. Contact SMC if a solution other than water is to be used.

Internal circuits

Lead wire colors inside [] are those prior to conformity with IEC standards.

D-Y7BAL/2 wire

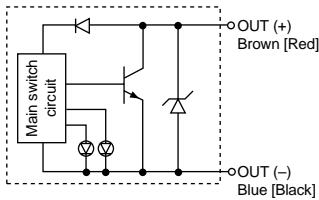

Indicator light/Display method

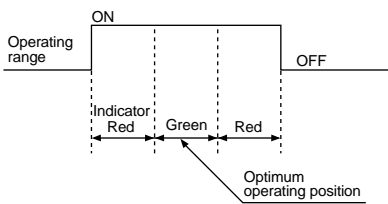

Weights

Model	Lead wire length	
	Unit: g	
D-Y7BAL	3m	
	51	

Dimensions

D-Y7BAL

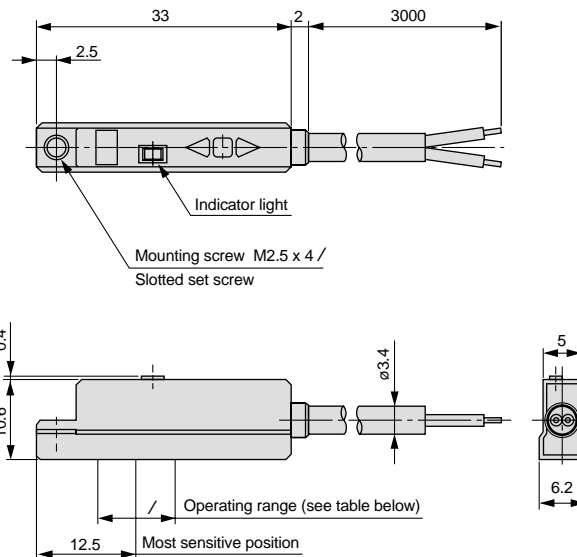

Bore size	Bore size (mm)									
	12	16	20	25	32	40	50	63	80	100
Operating range	3.5	5	5	5	6	6	6	6	6	6.5
Operating range /(mm)										

Note) This is a standard including hysteresis, and is not guaranteed. There may be large variations depending on the surrounding environment (variations on the order of $\pm 30\%$).

Magnetic Field Resistant 2 Color Indication Solid State Switches/Rail Mount Type D-P5DWL

Grommet

Operational in an environment with magnetic field disturbance (AC magnetic field).



Caution

Handling Precautions

For use with single-phase AC welder. Cannot be used with DC inverter welder (includes rectifying type), arc welder, or condenser type welder.

Auto Switch Internal Circuit

Lead wire colors inside [] are those prior to conformity with IEC standards.

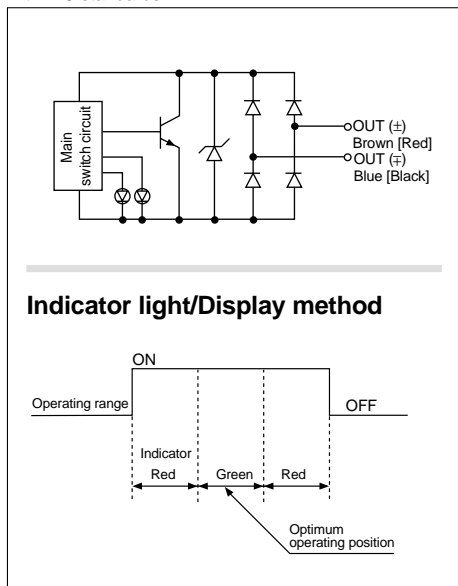

Auto Switch Specifications

D-P5DW (with indicator light)	
Auto switch part no.	D-P5DWL
Wiring type	2 wire (non-polar)
Applicable load	24VDC relay, PLC
Load voltage	24VDC (20 to 28VDC)
Load current	6 to 40mA or less
Internal voltage drop	5V or less
Leakage current	1mA or less at 24VDC
Operating time	40ms or less
Indicator light	Actuated position Red LED lights up Optimum operating position ... Green LED lights up

• Lead wire — Oil resistant, heavy duty vinyl cord, $\phi 6$, 0.5mm², 2 wire (Brown, Blue [Red, Black]), 3m (Note) Refer to page 57 for auto switch common specifications and lead wire lengths.

Magnetic Field Resistance

When the AC welding current is 16000A or less, the operational distance between the welding conductor (welding gun or cable) and the cylinder or auto switch is 0mm. Consult SMC when exceeding 16000A.

Auto Switch Weights

Model	Lead wire length	
	3m	5m
D-P5DWL	150	240

Unit: g

Dimensions

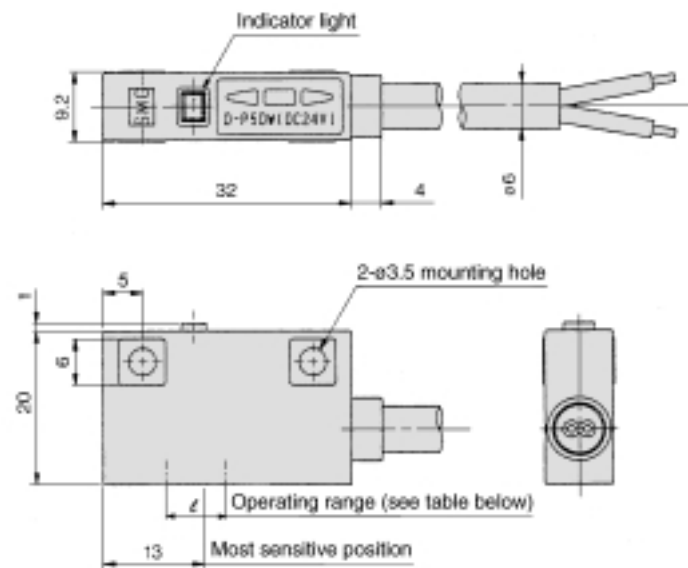

Bore size	Bore size (mm)				
	40	50	63	80	100
Operating range	4.1	3.9	4.8	4.2	4.2
Operating range Δ (mm)	4.1	3.9	4.8	4.2	4.2

Note) This is a standard including hysteresis, and is not guaranteed. There may be large variations depending on the surrounding environment (variations on the order of $\pm 30\%$).



Series MGP Safety Instructions

These safety instructions are intended to prevent a hazardous situation and/or equipment damage. These instructions indicate the level of potential hazard by a label of "**Caution**", "**Warning**" or "**Danger**". To ensure safety, be sure to observe ISO 4414 Note 1), JIS B 8370 Note 2) and other safety practices.

 **Caution** : Operator error could result in injury or equipment damage.

 **Warning** : Operator error could result in serious injury or loss of life.

 **Danger** : In extreme conditions, there is a possible result of serious injury or loss of life.

Note 1) ISO 4414: Pneumatic fluid power – Recommendations for the application of equipment to transmission and control systems

Note 2) JIS B 8370: General Rules for Pneumatic Equipment

Warning

1. The compatibility of pneumatic equipment is the responsibility of the person who designs the pneumatic system or decides its specifications.

Since the products specified here are used in various operating conditions, their compatibility for the specific pneumatic system must be based on specifications or after analysis and/or tests to meet your specific requirements.

2. Only trained personnel should operate pneumatically operated machinery and equipment.

Compressed air can be dangerous if handled incorrectly. Assembly, handling or repair of pneumatic systems should be performed by trained and experienced operators.

3. Do not service machinery/equipment or attempt to remove components until safety is confirmed.

1. Inspection and maintenance of machinery/equipment should only be performed after confirmation of safe locked-out control positions.
2. When equipment is to be removed, confirm the safety process as mentioned above. Cut the supply pressure for this equipment and exhaust all residual compressed air in the system.
3. Before machinery/equipment is restarted, take measures to prevent shooting-out of cylinder piston rod, etc. (Bleed air into the system gradually to create back pressure.)

4. Contact SMC if the product is to be used in any of the following conditions:

1. Conditions and environments beyond the given specifications, or if product is used outdoors.
2. Installation on equipment in conjunction with atomic energy, railway, air navigation, vehicles, medical equipment, food and beverages, recreation equipment, emergency stop circuits, press applications, or safety equipment.
3. An application which has the possibility of having negative effects on people, property, or animals, requiring special safety analysis.



Series MGP Actuator Precautions 1

Be sure to read before handling.

Design

⚠ Warning

1. **There is a danger of sudden action by air cylinders if sliding parts of machinery are twisted, etc., and changes in forces occur.**

In such cases, human injury may occur; e.g., by catching hands or feet in the machinery, or damage to the machinery itself may occur. Therefore, the machine should be designed to avoid such dangers.

2. **A protective cover is recommended to minimize the risk of personal injury.**

If a stationary object and moving parts of a cylinder are in close proximity, personal injury may occur. Design the structure to avoid contact with the human body.

3. **Securely tighten all stationary parts and connected parts so that they will not become loose.**

Especially when a cylinder operates with high frequency or is installed where there is a lot of vibration, ensure that all parts remain secure.

4. **A deceleration circuit or shock absorber, etc., may be required.**

When a driven object is operated at high speed or the load is heavy, a cylinder's cushion will not be sufficient to absorb the impact. Install a deceleration circuit to reduce the speed before cushioning, or install an external shock absorber to relieve the impact. In this case, the rigidity of the machinery should also be examined.

5. **Consider a possible drop in circuit pressure due to a power outage, etc.**

When a cylinder is used in a clamping mechanism, there is a danger of work pieces dropping if there is a decrease in clamping force due to a drop in circuit pressure caused by a power outage, etc. Therefore, safety equipment should be installed to prevent damage to machinery and human injury. Suspension mechanisms and lifting devices also require consideration for drop prevention.

6. **Consider a possible loss of power source.**

Measures should be taken to protect against human injury and equipment damage in the event that there is a loss of power to equipment controlled by air pressure, electricity or hydraulics, etc.

7. **Design circuitry to prevent sudden lurching of driven objects.**

When a cylinder is driven by an exhaust center type directional control valve or when starting up after residual pressure is exhausted from the circuit, etc., the piston and its driven object will lurch at high speed if pressure is applied to one side of the cylinder because of the absence of air pressure inside the cylinder. Therefore, equipment should be selected and circuits designed to prevent sudden lurching, because there is a danger of human injury and/or damage to equipment when this occurs.

8. **Consider emergency stops.**

Design so that human injury and/or damage to machinery and equipment will not be caused when machinery is stopped by a safety device under abnormal conditions, a power outage or a manual emergency stop.

9. **Consider the action when operation is restarted after an emergency stop or abnormal stop.**

Design the machinery so that human injury or equipment damage will not occur upon restart of operation. When the cylinder has to be reset at the starting position, install safe manual control equipment.

Selection

⚠ Warning

1. **Confirm the specifications.**

The products advertised in this catalog are designed according to use in industrial compressed air systems. If the products are used in conditions where pressure, temperature, etc., are out of specification, damage and/or malfunction may be caused. Do not use in these conditions. (Refer to specifications.)

Consult SMC if you use a fluid other than compressed air.

2. **Intermediate stops.**

When intermediate stopping of a cylinder piston is performed with a 3 position closed center type directional control valve, it is difficult to achieve stopping positions as accurate and minute as with hydraulic pressure due to the compressibility of air.

Furthermore, since valves and cylinders, etc., are not guaranteed for zero air leakage, it may not be possible to hold a stopped position for an extended period of time. Contact SMC in case it is necessary to hold a stopped position for an extended period.

⚠ Caution

1. **Operate within the limits of the maximum usable stroke.**

The piston rod will be damaged when operated with the stroke exceeding the maximum stroke range. Refer to the air cylinder selection procedures regarding the maximum usable stroke.

2. **Operate the piston within a range such that collision damage will not occur at the end of the stroke.**

Operate within a range such that damage will not occur when the piston having inertial force stops by striking the cover at the stroke end. Refer to the cylinder selection procedures for the range within which damage will not occur.

3. **Use a speed controller to adjust the cylinder drive speed, gradually increasing from a low speed to the desired speed setting.**

4. **Provide an intermediate support for a cylinder with a long stroke.**

If the cylinder has a long stroke, provide an intermediate support to prevent the rod from sagging and the tube from flexing, as well as to prevent damage to the rod due to vibrations or external loads.

Mounting

⚠ Caution

1. **Be sure to connect the rod and the load so that their axial center and movement directions match.**

If they do not match, stress could be applied to the rod and the tube, causing the inner surface of the tube, the bushing, the rod surface, and the seals to wear and to become damaged.

2. **When an external guide is used, connect the external slider and the load in such a way that there is no interference at any point within the stroke.**

Standard Type
MGP

With Air Cushion
MGP

With End Lock
MGP

Heavy Duty
Guide Rod Type
MGPS

Order Made
Specifications

Auto Switches

Precautions



Series MGP Actuator Precautions 2

Be sure to read before handling.

Mounting

⚠ Caution

3. **Do not scratch or gouge the sliding parts of the cylinder tube or piston rod, etc., by striking or grasping them with other objects.**

Cylinder bores are manufactured to precise tolerances, so that even a slight deformation may cause faulty operation. Also, scratches or gouges, etc., in the piston rod may lead to damaged seals and cause air leakage.

4. **Prevent the rotating parts from seizing.**

Apply grease to rotating parts (such as the pin) to prevent them from seizing.

5. **Do not use until you can verify that equipment can operate properly.**

Following mounting, maintenance or conversions, verify correct mounting by suitable function and leakage tests after compressed air and power are connected.

6. **Instruction manual**

The product should be mounted and operated after thoroughly reading the manual and understanding its contents.

Keep the instruction manual where it can be referred to as needed.

Piping

⚠ Caution

1. **Preparation before piping**

Before piping is connected, it should be thoroughly blown out with air (flushing) or washed to remove chips, cutting oil and other debris from inside the pipe.

2. **Wrapping of pipe tape**

When screwing together pipes and fittings, etc., be certain that chips from the pipe threads and sealing material do not get inside the piping.

Also, when pipe tape is used, leave 1.5 to 2 thread ridges exposed at the end of the threads.

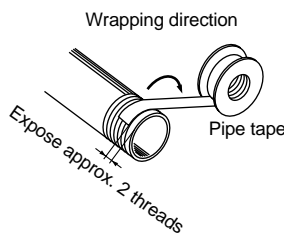

Lubrication

⚠ Caution

1. **Lubrication of lube type cylinder**

Install a lubricator in the circuit, and use class 1 turbine oil (with no additives) ISO VG32. Do not use machine oil or spindle oil.

2. **Lubrication of non-lube type cylinder**

The cylinder is lubricated at the factory and can be used without any further lubrication.

However, in the event that it will be lubricated, use class 1 turbine oil (with no additives) ISO VG32.

Stopping lubrication later may lead to malfunction due to the loss of the original lubricant. Therefore, lubrication must be continued once it has been started.

Air Supply

⚠ Warning

1. **Use clean air.**

Do not use compressed air that includes chemicals, synthetic oils containing organic solvents, salt or corrosive gases, etc., as it can cause damage or malfunction.

⚠ Caution

1. **Install air filters.**

Install air filters at the upstream side of valves. The filtration degree should be 5µm or finer.

2. **Install an air dryer, after-cooler or water separator, etc.**

Air that includes excessive drainage may cause malfunction of valves and other pneumatic equipment. To prevent this, install an air dryer, after-cooler or water separator, etc.

3. **Use the product within the specified range of fluid and ambient temperature.**

Take measures to prevent freezing, since moisture in circuits will be frozen under 5°C, and this may cause damage to seals and lead to malfunction.

Refer to SMC's "Air Cleaning Equipment" catalog for further details on compressed air quality.

Operating Environment

⚠ Warning

1. **Do not use in environments where there is a danger of corrosion.**

Refer to the construction drawings regarding cylinder materials.

2. **In dusty locations or where water, oil, etc., splash on the equipment, install a protective cover over the rod.**

Use cylinders with a heavy duty scraper (-XC4) in dusty areas. Use water resistant cylinders in areas where liquids are splashed or sprayed

3. **When using auto switches, do not operate in an environment with strong magnetic fields.**

Maintenance

⚠ Warning

1. **Perform maintenance according to the procedure indicated in the instruction manual.**

If handled improperly, malfunction and damage of machinery or equipment may occur.

2. **Removal of equipment, and supply/exhaust of compressed air.**

When machinery is removed, first check measures to prevent dropping of driven objects and run-away of equipment, etc. Then cut off the supply pressure and electric power, and exhaust all compressed air from the system.

When machinery is restarted, proceed with caution after confirming measures to prevent cylinder lurching.

⚠ Caution

1. **Drain flushing**

Remove drainage from air filters regularly.



Series MGP Auto Switch Precautions 1

Be sure to read before handling.

Design and Selection

Warning

1. Confirm the specifications.

Read the specifications carefully and use this product appropriately. The product may be damaged or malfunction if it is used outside the range of specifications for current load, voltage, temperature or impact.

2. Take precautions when multiple cylinders are used close together.

When multiple auto switch cylinders are used in close proximity, magnetic field interference may cause the switches to malfunction. Maintain a minimum cylinder separation of 40mm. (When the allowable separation is indicated for each cylinder series, use the specified value.)

3. Pay attention to the length of time that a switch is ON at an intermediate stroke position.

When an auto switch is placed at an intermediate position of the stroke and a load is driven at the time the piston passes, the auto switch will operate, but if the speed is too great the operating time will be shortened and the load may not operate properly. The maximum detectable piston speed is:

$$V(\text{mm/s}) = \frac{\text{Auto switch operating range (mm)}}{\text{Load operation time (ms)}} \times 1000$$

4. Keep wiring as short as possible.

<Reed switches>

As the length of the wiring to a load gets longer, the rush current at switching ON becomes greater, and this may shorten the product's life. (The switch will stay ON all the time.)

- 1) For an auto switch without a contact protection circuit, use a contact protection box when the wire length is 5m or longer.
- 2) Even if an auto switch has a built-in contact protection circuit, when the wiring is more than 30m long, it is not able to adequately absorb the rush current and its life maybe reduced. It is necessary to connect a contact protection box in order to extend its life. Contact SMC in this case.

<Solid state switches>

- 3) Although wire length should not affect switch function, use a wire 100m or shorter.

5. Pay attention to the internal voltage drop of switches.

<Reed switches>

- 1) Switches with an indicator light (Except D-Z76)
 - If auto switches are connected in series as shown below, take note that there will be a large voltage drop because of internal resistance in the light emitting diodes. (Refer to internal voltage drop in the auto switch specifications.)

[The voltage drop will be "n" times larger when "n" auto switches are connected.]

Even though an auto switch operates normally, the load may not operate.

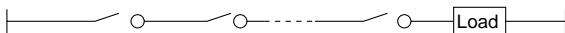

- In the same way, when operating below a specified voltage, although an auto switch may operate normally, the load may not operate. Therefore, the formula below should be satisfied after confirming the minimum operating voltage of the load.

$$\text{Supply voltage} - \text{Internal voltage drop of switch} > \text{Minimum operating voltage of load}$$

- 2) If the internal resistance of a light emitting diode causes a problem, select a switch without an indicator light (Model D-Z80).

<Solid state switches>

- 3) Generally, the internal voltage drop will be greater with a 2 wire solid state auto switch than with a reed switch. Take the same precautions as in 1).

Also, note that a 12VDC relay is not applicable.

6. Pay attention to leakage current.

<Solid state switches>

With a 2 wire solid state auto switch, current (leakage current) flows to the load to operate the internal circuit even when in the OFF state.

$$\text{Operating current of load (OFF condition)} > \text{Leakage current}$$

If the criteria given in the above formula are not met, it will not reset correctly (stays ON). Use a 3 wire switch if this specification will not be satisfied.

Moreover, leakage current flow to the load will be "n" times larger when "n" auto switches are connected in parallel.

7. Do not use a load that generates surge voltage.

<Reed switches>

If driving a load such as a relay that generates a surge voltage, use a switch with a built-in contact protection circuit or use a contact protection box.

<Solid state switches>

Although a zener diode for surge protection is connected at the output side of a solid state auto switch, damage may still occur if the surge is applied repeatedly. When a load, such as a relay or solenoid which generates surge is directly driven, use a type of switch with a built-in surge absorbing element.

8. Cautions for use in an interlock circuit

When an auto switch is used for an interlock signal requiring high reliability, devise a double interlock system to avoid trouble by providing a mechanical protection function, or by also using another switch (sensor) together with the auto switch. Also perform periodic maintenance and confirm proper operation.

9. Ensure sufficient clearance for maintenance activities.

When designing an application, be sure to allow sufficient clearance for maintenance and inspections.



Series MGP Auto Switch Precautions 2

Be sure to read before handling.

Mounting and Adjustment

Warning

1. Do not drop or bump.

Do not drop, bump or apply excessive impacts (300m/s² or more for reed switches and 1000m/s² or more for solid state switches) while handling.

Although the body of the switch may not be damaged, the inside of the switch could be damaged and cause a malfunction.

2. Do not carry a cylinder by the auto switch lead wires.

Never carry a cylinder by its lead wires. This may not only cause broken lead wires, but it may cause internal elements of the switch to be damaged by the stress.

3. Mount switches using the proper fastening torque.

When a switch is tightened beyond the range of fastening torque, the mounting screws, mounting bracket or switch may be damaged. On the other hand, tightening below the range of fastening torque may allow the switch to slip out of position.

4. Mount a switch at the center of the operating range.

Adjust the mounting position of an auto switch so that the piston stops at the center of the operating range (the range in which a switch is ON).

(The mounting position shown in the catalog indicates the optimum position at stroke end.) If mounted at the end of the operating range (around the borderline of ON and OFF), operation will be unstable.

Wiring

Warning

1. Avoid repeatedly bending or stretching lead wires.

Broken lead wires will result from wiring patterns which repeatedly apply bending stress or stretching force to the lead wires.

2. Be sure to connect the load before power is applied.

<2 wire type>

If the power is turned ON when an auto switch is not connected to a load, the switch will be instantly damaged because of excess current.

3. Confirm proper insulation of wiring.

Be certain that there is no faulty wiring insulation (contact with other circuits, ground fault, improper insulation between terminals, etc.). Damage may occur due to excess current flow into a switch.

4. Do not wire with power lines or high voltage lines.

Wire separately from power lines or high voltage lines, avoiding parallel wiring or wiring in the same conduit with these lines. Control circuits, including auto switches, may malfunction due to noise from these other lines.

Wiring

Warning

5. Do not allow short circuit of loads.

<Reed switches>

If the power is turned ON with a load in a short circuited condition, the switch will be instantly damaged because of excess current flow into the switch.

<Solid state switches>

All models of PNP output type switches do not have built-in short circuit protection circuits. If loads are short circuited, the switches will be instantly damaged as in the case of reed switches.

Take special care to avoid reverse wiring with the brown [red] power supply line and the black [white] output line on 3 wire type switches.

6. Avoid incorrect wiring.

<Reed switches>

A 24VDC switch with indicator light has polarity. The brown [red] lead wire or terminal no. 1 is (+), and the blue [black] lead wire or terminal no. 2 is (-).

- 1) If connections are reversed, a switch will operate, however, the light emitting diode will not light up.

Also note that a current greater than that specified will damage a light emitting diode and it will no longer operate.

Applicable models: D-Z73

<Solid state switches>

- 1) If connections are reversed on a 2 wire type switch, the switch will not be damaged if protected by a protection circuit, but the switch will always stay in an ON state. However, it is still necessary to avoid reversed connections, since the switch could be damaged by a load short circuit in this condition.
- 2) If connections are reversed (power supply line + and power supply line -) on a 3 wire type switch, the switch will be protected by a protection circuit. However, if the power supply line (+) is connected to the blue [black] wire and the power supply line (-) is connected to the black [white] wire, the switch will be damaged.

* Lead wire color changes

Lead wire colors of SMC switches have been changed in order to meet NECA Standard 0402 for production beginning September, 1996 and thereafter. Please refer to the tables provided. Special care should be taken regarding wire polarity during the time that the old colors still coexist with the new colors.

2 wire

	Old	New
Output (+)	Red	Brown
Output (-)	Black	Blue

3 wire

	Old	New
Power supply	Red	Brown
GND	Black	Blue
Output	White	Black

Solid state with diagnostic output

	Old	New
Power supply	Red	Brown
GND	Black	Blue
Output	White	Black
Diagnostic Output	Yellow	Orange

Solid state with latch type diagnostic output

	Old	New
Power supply	Red	Brown
GND	Black	Blue
Output	White	Black
Latch type diagnostic output	Yellow	Orange

Note) Lead wire colors inside [] are those prior to conformity with NECA standards.



Series MGP Auto Switch Precautions 3

Be sure to read before handling.

Operating Environment

⚠ Warning

1. Never use in an atmosphere of explosive gases.

The construction of auto switches is not intended to prevent explosion. Never use in an atmosphere with an explosive gas since this may cause a serious explosion.

2. Do not use in an area where a magnetic field is generated.

Auto switches will malfunction or magnets inside cylinders will become demagnetized. (Consult SMC regarding the availability of a magnetic field resistant auto switch.)

3. Do not use in an environment where the auto switch will be continually exposed to water.

Do not use switches in applications where continually exposed to water splash or spray. Poor insulation or swelling of the potting resin inside switches may cause malfunction.

4. Do not use in an environment with oil or chemicals.

Consult SMC if auto switches will be used in an environment with coolant, cleaning solvent, various oils or chemicals. If auto switches are used under these conditions for even a short time, they may be adversely affected by improper insulation, malfunction due to swelling of the potting resin, or hardening of the lead wires.

5. Do not use in an environment with temperature cycles.

Consult SMC if switches are used where there are temperature cycles other than normal temperature changes, as they may be adversely affected internally.

6. Do not use in an environment where there is excessive impact shock.

<Reed switches>

When excessive impact (300m/s² or more) is applied to a reed switch during operation, the contact point will malfunction and generate or cut off a signal momentarily (1ms or less). Consult SMC regarding the need to use a solid state switch depending upon the environment.

7. Do not use in an area where surges are generated.

<Solid state switches>

When there are units (solenoid type lifter, high frequency induction furnace, motor, etc.) which generate a large amount of surge in the area around cylinders with solid state auto switches, this may cause deterioration or damage to the switch. Avoid sources of surge generation and crossed lines.

8. Avoid accumulation of iron waste or close contact with magnetic substances.

When a large amount of ferrous waste such as machining chips or spatter is accumulated, or a magnetic substance (something attracted by a magnet) is brought into close proximity with an auto switch cylinder, it may cause the auto switch to malfunction due to a loss of the magnetic force inside the cylinder.

Maintenance

⚠ Warning

1. Perform the following maintenance periodically in order to prevent possible danger due to unexpected auto switch malfunction.

- 1) Securely tighten switch mounting screws.
If screws become loose or the mounting position is dislocated, retighten them after readjusting the mounting position.
- 2) Confirm that there is no damage to lead wires.
To prevent faulty insulation, replace switches or repair lead wires, etc., if damage is discovered.
- 3) Confirm the lighting of the green light on the 2 color indicator type switch.
Confirm that the green LED is on when stopped at the established position. If the red LED is on, the mounting position is not appropriate. Readjust the mounting position until the green LED lights up.

Other

⚠ Warning

1. Consult SMC concerning water resistance, elasticity of lead wires, and usage at welding sites, etc.

Standard Type
MGP

With Air Cushion
MGP

With End Lock
MGP

Heavy Duty
Guide Rod Type
MGPS

Order Made
Specifications

Auto Switches

Precautions



Series MGP Specific Product Precautions

Be sure to read before handling. Refer to pages 64 through 69 for safety instructions, actuator precautions and auto switch precautions.

Mounting

Warning

1. Do not put hands or fingers, etc. between the plate and body.

Be careful that hands or fingers, etc., do not get caught in the space between the cylinder body and the plate when air pressure is applied.

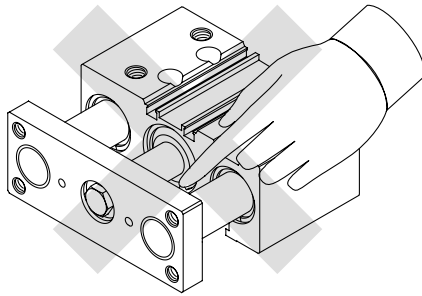

Caution

1. Do not scratch or nick the sliding parts of the piston rod and guide rods.

Damage to seals can cause air leaks or malfunction, etc.

2. Bottom of cylinder.

The guide rods protrude from the bottom of the cylinder at the end of the retracting stroke, and therefore, in cases where the cylinder is to be bottom mounted, it is necessary to provide by-pass ports in the mounting surface for the guide rods, as well as holes for the hexagon socket head screws which are used for mounting.

Moreover, in applications where impact occurs from a stopper, etc., the mounting bolts should be inserted to a depth of 2d or more (1.5d or more for MGPS).

Series MGP

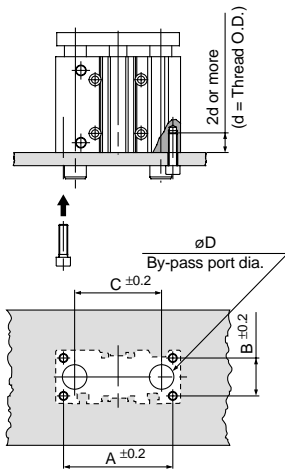

Bore size (mm)	A (mm)	B (mm)	C (mm)	D (mm)		Hexagon socket mounting bolt
				MGPM	MGPL	
12	50	18	41	10	8	M4 x 0.7
16	56	22	46	12	10	M5 x 0.8
20	72	24	54	14	12	M5 x 0.8
25	82	30	64	18	15	M6 x 1.0
32	98	34	78	22	18	M8 x 1.25
40	106	40	86	22	18	M8 x 1.25
50	130	46	110	27	22	M10 x 1.5
63	142	58	124	27	22	M10 x 1.5
80	180	54	156	33	28	M12 x 1.75
100	210	62	188	39	33	M14 x 2.0

Series MGPS

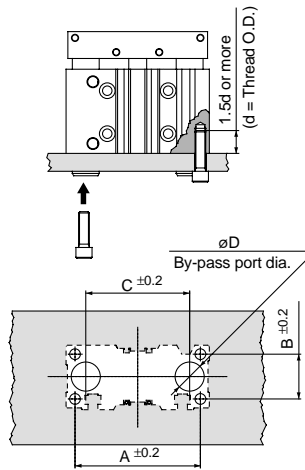

Bore size (mm)	A (mm)	B (mm)	C (mm)	D (mm)	Hexagon socket mounting bolt
50	140	50	116	32	M12 x 1.75
80	214	66	170	47	M16 x 2

Cushion

When equipped with air cushion

Caution

1. Keep the adjustment range of the cushion valve within 3 rotations of the completely closed position.

When adjusting the cushion valve, use the following screw driver or hexagon wrenches. Keep the adjustment range of the cushion valve within 3 rotations of the completely closed position. Air leakage will occur if operated after opening by 4 rotations or more. Furthermore, a stopper mechanism is provided for the cushion valve, and it should not be forced open beyond that position.

Bore size (mm)	Applicable tool
16	Flat head watchmakers screw driver 3mm
20, 25, 32, 40	JIS B4648 hexagon wrench key 1.5
50, 63	JIS B4648 hexagon wrench key 2.5
80, 100	JIS B4648 hexagon wrench key 4

2. Be sure to activate the air cushion at the cylinder stroke end.

Be sure to activate the air cushion at the end of the cylinder stroke. When it is intended to operate with the cushion valve fully opened, select a cylinder equipped with rubber bumper. If operated without confirming this point, the piston rod assembly, etc., may be damaged.

3. Be sure to operate a cylinder equipped with air cushion to the end of the stroke.

If it is not operated to the end of the stroke, the effect of the air cushion will not be fully exhibited. Consequently, in cases where the stroke is regulated by an external stopper, etc., caution must be exercised, as the air cushion may become completely ineffective.

Piping

Caution

Depending on the operating conditions, piping port positions can be changed by using a plug.

1. For M5

After tightening by hand, tighten an extra 1/6 to 1/4 rotation with a tightening tool.

2. For taper thread

Use the correct tightening torques listed below. Before tightening the plug, wrap pipe tape around it.

Connection thread size	Correct tightening torque N·m
R 1/8	7 to 9
R 1/4	12 to 14
R 3/8	22 to 24



Series MGP Specific Product Precautions

Be sure to read before handling. Refer to pages 64 through 69 for safety instructions, actuator precautions and auto switch precautions.

Use the recommended pneumatic circuits.

⚠ Caution

- This is necessary for proper operation and release of the lock.

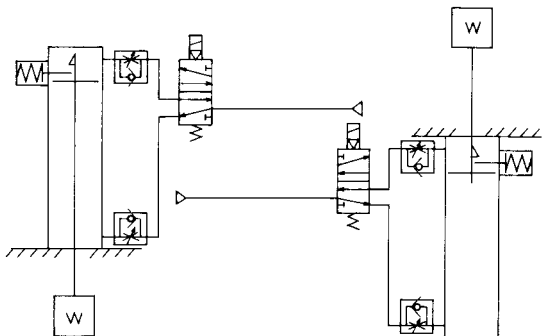

With rear lock

With front lock

Operation

⚠ Caution

1. Do not use 3 position solenoid valves.

Avoid use in combination with 3 position solenoid valves (especially closed center metal seal types). If pressure is trapped in the port on the lock mechanism side, the cylinder cannot be locked.

Furthermore, even after being locked, the lock may be released after some time, due to air leaking from the solenoid valve and entering the cylinder.

2. Back pressure is required when releasing the lock.

Before starting operation, be sure to control the system so that air is supplied to the side without the lock mechanism as shown in the figure above. There is a possibility that the lock may not be released. (Refer to the section on releasing the lock.)

3. Release the lock when mounting or adjusting the cylinder.

If mounting or other work is performed when the cylinder is locked, the lock unit may be damaged.

4. Operate with a load ratio of 50% or less.

If the load ratio exceeds 50%, this may cause problems such as failure of the lock to release, or damage to the lock unit. Furthermore, do not exceed the operating ranges indicated in the series MGP catalog (Best Pneumatics No. 2) when making selections.

5. Do not operate multiple synchronized cylinders.

Avoid applications in which two or more end lock cylinders are synchronized to move one workpiece, as one of the cylinder locks may not be able to release when required.

6. Use a speed controller with the meter-out function.

It may not be possible to release the lock with meter-in control.

7. Be sure to operate completely to the cylinder stroke end on the side with the lock.

If the cylinder piston does not reach the end of the stroke, locking and unlocking may not be possible.

8. Do not use an air cylinder as an air-hydro cylinder.

This will cause leakage of hydraulic fluid.

9. Adjust an auto switch's position so that it operates for movement to both the stroke and backlash (2mm) positions.

A 2 color indication switch adjusted for green indication at the stroke end may change to red indication after the backlash return, but this is not abnormal.

Operating Pressure

⚠ Caution

1. Use air pressure of at least 0.15MPa for the port on the lock mechanism side. This is necessary to release the lock.

Exhaust Speed

⚠ Caution

1. Locking will occur automatically if the pressure applied to the port on the lock mechanism side falls to 0.05MPa or less. In cases where the piping on the lock mechanism side is long and thin, or the speed controller is separated at some distance from the cylinder port, the exhaust speed will be reduced. Take note that some time may be required for the lock to engage. In addition, clogging of a silencer mounted on the solenoid valve exhaust port can produce the same effect.

Releasing the Lock

⚠ Warning

1. Before releasing the lock, be sure to supply air to the side without the lock mechanism, so that there is no load applied to the lock mechanism when it is released. (Refer to the recommended pneumatic circuits.) If the lock is released when the port on the other side is in an exhaust state, and with a load applied to the lock unit, the lock unit may be subjected to an excessive force and be damaged. Furthermore, sudden movement of the piston rod is very dangerous.

Manual Release

⚠ Caution

1. Non-locking type manual release

Insert the accessory bolt from the top of the rubber cap (it is not necessary to remove the rubber cap), and after screwing it into the lock piston, pull it to release the lock. If you stop pulling the bolt, the lock will return to an operational state. Thread sizes, pulling forces and strokes are as shown below.

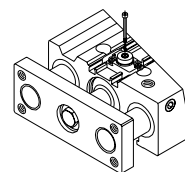

Bore size (mm)	Thread size	Pulling force N	Stroke (mm)
20, 25, 32	M2.5 x 0.45 x 25/or more	4.9N	2
40, 50, 63	M3 x 0.5 x 30/or more	10N	3
80, 100	M5 x 0.8 x 40/or more	24.5N	3

* Remove the bolt for normal operation. It can cause lock malfunction or faulty release.

2. Locking type manual release

While pushing the M/O knob turn it 90° counter clockwise. The lock is released (and remains in a released state) by aligning the ▲ mark on the cap with the ▼ OFF mark on the M/O knob. To operate the lock, turn the M/O knob 90° clockwise while pushing it all the way down, and align the ▲ mark on the cap with the ▼ ON mark on the M/O knob. When doing this, be sure that it locks into place with a click. Failure to click into place properly, can cause the lock to disengage.

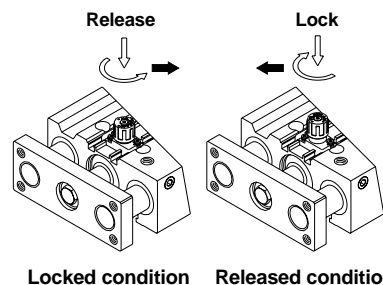

Standard Type
MGP

With Air Cushion
MGP

With End Lock
MGP

Heavy Duty
Guide Rod Type
MGPS

Order Made
Specifications

Auto Switches

Precautions



SMC'S GLOBAL MANUFACTURING, DISTRIBUTION AND SERVICE NETWORK

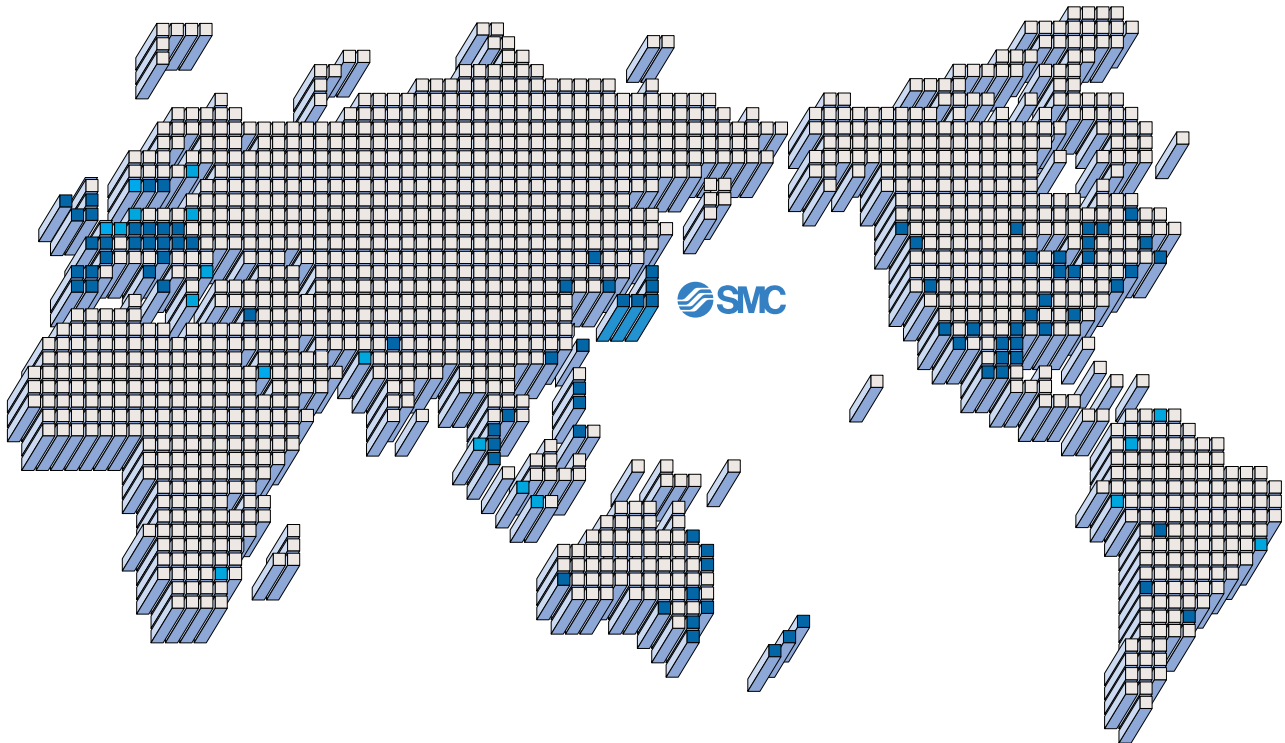

EUROPE

AUSTRIA
SMC Pneumatik GmbH

CZECH
SMC Czech s.r.o.

DENMARK
SMC Pneumatik A/S

FINLAND
SMC Pneumatiikka OY

FRANCE
SMC Pneumatique SA

GERMANY
SMC Pneumatik GmbH

HUNGARY
SMC Hungary Kft.

IRELAND
SMC Pneumatics (Ireland) Ltd.

ITALY
SMC Italia S.p.A.

NETHERLANDS
SMC Pneumatics BV.

NORWAY
SMC Pneumatics Norway A/S

ROMANIA
SMC Romania s.r.l.

RUSSIA
SMC Pneumatik LLC.

SLOVAKIA
SMC Slovakia s.r.o.

SLOVENIA
SMC Slovenia d.o.o.

EUROPE

SPAIN/PORTUGAL
SMC España, S.A.

SWEDEN
SMC Pneumatics Sweden AB

SWITZERLAND
SMC Pneumatik AG.

UK
SMC Pneumatics (U.K.) Ltd.

ASIA

CHINA
SMC (China) Co., Ltd.

HONG KONG
SMC Pneumatics (Hong Kong) Ltd.

INDIA
SMC Pneumatics (India) Pvt. Ltd.

MALAYSIA
SMC Pneumatics (S.E.A.) Sdn. Bhd.

PHILIPPINES
SMC Pneumatics (Philippines), Inc.

SINGAPORE
SMC Pneumatics (S.E.A.) Pte. Ltd.

SOUTH KOREA
SMC Pneumatics Korea Co., Ltd.

TAIWAN
SMC Pneumatics (Taiwan) Co., Ltd.

THAILAND
SMC Thailand Ltd.

NORTH AMERICA

CANADA
SMC Pneumatics (Canada) Ltd.

MEXICO
SMC Corporation (Mexico) S.A. de C.V.

USA
SMC Pneumatics, Inc.

SOUTH AMERICA

ARGENTINA
SMC Argentina S.A.

BOLIVIA
SMC Pneumatics Bolivia S.R.L.

BRAZIL
SMC Pneumaticos Do Brazil Ltda.

CHILE
SMC Pneumatics (Chile) S.A.

VENEZUELA
SMC Neumatica Venezuela S.A.

OCEANIA

AUSTRALIA
SMC Pneumatics (Australia) Pty. Ltd.

NEW ZEALAND
SMC Pneumatics (N.Z.) Ltd.

SMC CORPORATION

1-16-4 Shimbashi, Minato-ku, Tokyo 105-0004, JAPAN
Tel: 03-3502-2740 Fax: 03-3508-2480
URL <http://www.smcworld.com>
© 2000 SMC CORPORATION All Rights Reserved