

Directional spool valves, direct operated, with solenoid actuation

Type 5-.WE

RE 23352

Edition: 2015-09

Replaces: 2012-04



- ▶ 5-chamber version
- ▶ Size 10
- ▶ Component series 5X
- ▶ Maximum operating pressure 420 bar [6091 psi]
- ▶ Maximum flow 150 l/min [39.6 US gpm]



Features

- ▶ 4/3-, 4/2- or 3/2-way version
- ▶ Porting pattern according to ISO 4401-05-04-0-05 and NFPA T3.5.1 R2-2002 D05
- ▶ High-power solenoid, optionally rotatable by 90°
- ▶ Electrical connection as individual connection
- ▶ Cartridge optionally equipped with PWM connector (fast switching amplifier, energy reduction)
- ▶ Manual override, optional
- ▶ Spool position monitoring, optional
- ▶ CE conformity according to the Low-Voltage Directive 2006/95/EC for electrical voltages > 50 VAC or > 75 VDC
- ▶ Solenoid coil with UR approval UL 429
- ▶ Approval according to CSA C22.2 No. 139-10, optional

Contents

Features	1
Ordering codes	2 ... 4
Symbols	5, 6
Function, section	7, 8
Technical data	9 ... 11
Characteristic curves	12
Performance limits	13 ... 15
Dimensions	16 ... 18
Over-current fuse and switch-off voltage peaks	19
Electrical connections, assignment	19
Mating connectors	20
Project planning information	20
Additional information	21

Ordering codes

01	02	03	04	05	06	07	08	09	10	11	12	13	14	15	16	17	18	19	20	
	5	-		WE	10		-	5X	/		E				/				=	*

01	Standard version (Maximum operating pressure 350 bar)	no code
	High-pressure version (Maximum operating pressure 420 bar)	H
02	5-chamber version	5
03	3 main ports	3
	4 main ports	4
04	Directional valve	WE
05	Size 10	10
06	Symbols e.g. C, E, EA, EB, etc; possible version see page 5 and 6.	
07	Component series 50 ... 59 (50 ... 59: unchanged installation and connection dimensions)	5X

Spool return

08	With spring return	no code
	With reinforced compression spring (for quick switching off)	D
	Without spring return	O
	Without spring return with detent	OF
09	High-power wet-pin solenoid with detachable coil	E
10	Direct voltage 12 V	G12
	Direct voltage 24 V	G24
	Direct voltage 26 V	G26
	Direct voltage 48 V	G48
	Direct voltage 96 V	G96
	Direct voltage 110 V	G110
	Direct voltage 125 V	G125
	Direct voltage 180 V	G180
	Direct voltage 205 V	G205
	Direct voltage 220 V	G220
Connection to AC voltage mains via control with rectifier (see table page 3 and 20).		
Electrical connections and available voltages see page 11		
11	Without manual override	no code
	With concealed manual override (standard)	N9 ¹⁾
	With concealed manual override and protective cap ³⁾	N8 ¹⁾
	With lockable manual override "mushroom button" (large)	N5 ^{1; 2)}
	With manual override "mushroom button" (large), not lockable	N6 ¹⁾

Corrosion resistance (outside)

12	None (valve housing primed)	no code
	Improved corrosion protection (240 h salt spray test according to EN ISO 9227); (only version "K4K")	J3

Electrical connection ⁵⁾

13	Individual connection	
	Without mating connector, with connector according to DIN EN 175301-803	K4 ⁴⁾
	Without mating connector, with connector according to DIN EN 175301-803 (coil with potted-in connector base and sealing element to valve housing (IP67); with version "J3" possible)	K4K ⁴⁾
	Without mating connector, 4-pole with connector M12x1, integrated interference protection circuit, status LED according to IEC 60947-5-2	K72L ^{4; 5)}
	Without mating connector, with AMP Junior-Timer connector	C4Z ⁴⁾
Additional electrical connections and available voltages see page 11		

Ordering codes

01	02	03	04	05	06	07	08	09	10	11	12	13	14	15	16	17	18	19	20	
	5	-		WE	10		-	5X	/		E				/				=	*

Spool position monitoring

14	Without position switch	no code
	- Inductive position switch type QM	
	Monitored spool position "a"	QMAG24
	Monitored spool position "b"	QMBG24
	Monitored spool position "0"	QM0G24
	- Inductive proximity sensor type QS	
	Monitored spool position "a"	QSAG24W
	Monitored spool position "b"	QSBG24W
	Monitored spool position "0"	QS0G24W
	Monitored spool position "0" and "a"	QS0AG24W
	Monitored spool position "0" and "b"	QS0BG24W
	Monitored spool position "a" and "b"	QSABG24W
	For more information, see data sheet 24830	

Switching time increase

15	Without switching time increase	no code
	With throttle screw	C
	With orifice \varnothing 0.6 mm [0.024 inch]	A06
	With orifice \varnothing 0.8 mm [0.031 inch]	A08
	With orifice \varnothing 1.0 mm [0.039 inch]	A10

Throttle insert

16	Without throttle insert	no code
	With throttle insert ^{6; 7)} :	
	Port	Throttle \varnothing in mm [inch]
		0.8 [0.031] 1.0 [0.039] 1.2 [0.047]
	P	= B08 = B10 = B12
	A	= H08 = H10 = H12
	B	= R08 = R10 = R12
	A and B	= N08 = N10 = N12
	T ⁸⁾	= X08 = X10 = X12
	Further throttle insert diameters upon request	

- 1) The manual override cannot be allocated a safety function. The manual override units may only be used up to a tank pressure of 50 bar.
- 2) With tank pressures above 50 bar, it cannot be guaranteed that the valve remains in the position switched by the "N5" manual override.
- 3) Protective cap must be removed prior to actuation.
- 4) Mating connectors, separate order, see page 20 and data sheet 08006.
- 5) M12x1 plug-in connection see data sheet 08010.
- 6) When the admissible valve performance limits are exceeded, installation of throttle inserts is to be intended (performance limits see page 13).
- 7) Not with low-temperature version "MT".
- 8) When throttle inserts are used in channel T, the pressure in the working ports and in case of connection to the tank chambers must not exceed 210 bar.

AC voltage mains (admissible voltage tolerance ± 10 %)	Nominal voltage of the DC solenoid in case of operation with alternat- ing voltage	Ordering code
100 V - 50/60 Hz	96 V	G96
110 V - 50/60 Hz	96 V	G96
200 V - 50/60 Hz	180 V	G180
230 V - 50/60 Hz	205 V	G205

 **Notice:**

Conversion from AC voltage to DC voltage requires a mating connector with rectifier (separate order, material no. **R901017025**).

Ordering codes

01	02	03	04	05	06	07	08	09	10	11	12	13	14	15	16	17	18	19	20		
	5	-		WE	10		-	5X	/		E				/				=		*

Control spool play

17	Standard	no code
	Minimum (to be selected in case of reduced leakage → higher level of oil cleanliness recommended)	T06
	Increased (to be selected in case of a hydraulic fluid/environment temperature difference > 25 K → increased internal leakage)	T12

Seal material

18	NBR seals	M
	FKM seals	V
	Seals for HFC hydraulic fluids	MH
	Low-temperature version	MT
	Observe compatibility of seals with hydraulic fluid used! (Other seals upon request)	
19	Approval according to CSA C22.2 No. 139-10	CSA
	Porting pattern according to ANSI B93.9 (if solenoid "a" is energized, channel P is connected to A)	AN
20	Further details in the plain text	*

Symbols: 2 spool positions

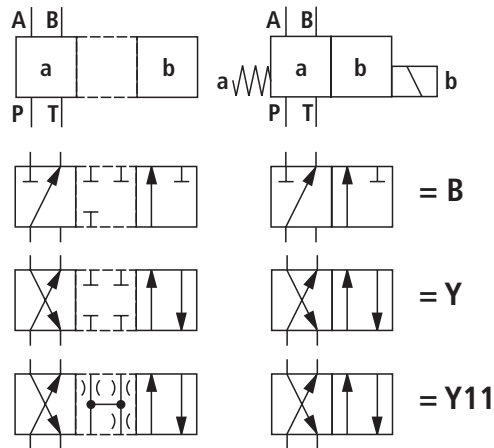
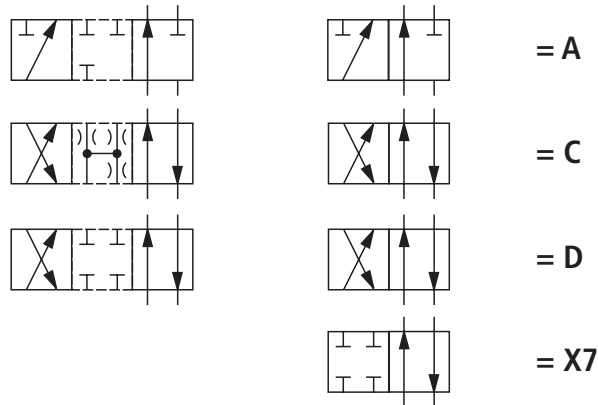
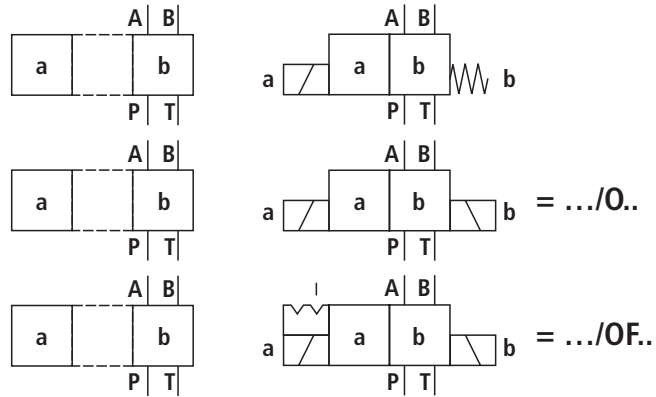

Notices:

- ▶ Representation according to DIN ISO 1219-1.
Hydraulic interim positions are shown by dashes.
- ▶ Other symbols upon request.

Symbols: 3 spool positions

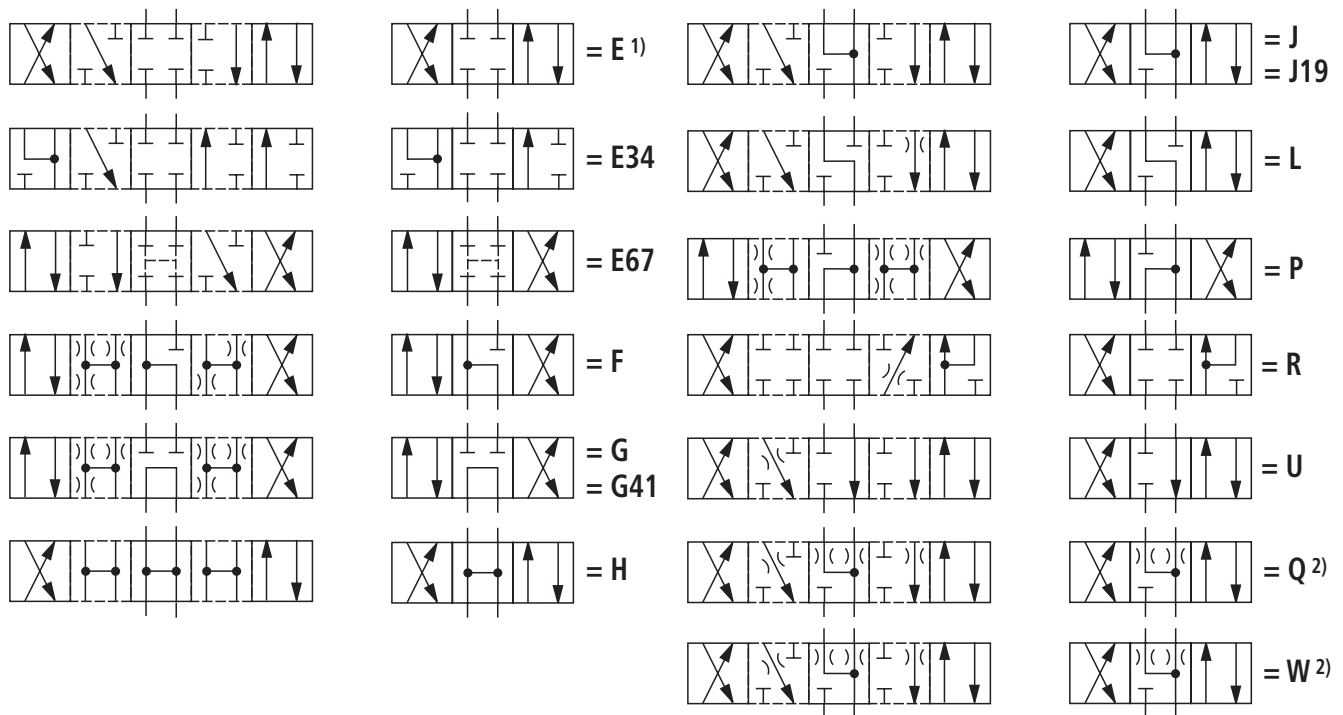
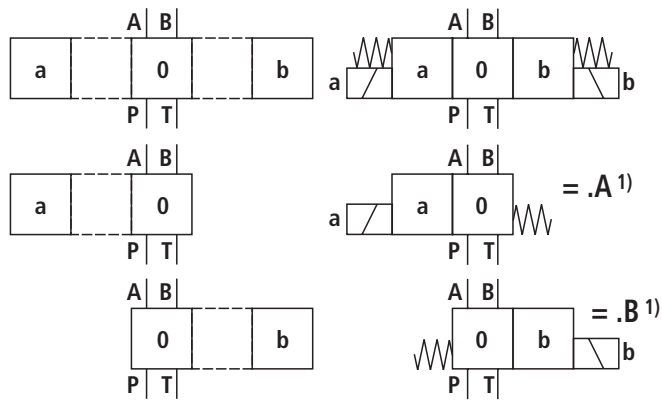

1) **Example:**

- ▶ Symbol E with spool position "a": ordering code **..EA..**
- ▶ Symbol E with spool position "b": ordering code **..EB..**

2) For symbol Q and W, see "Flow cross-section" page 9

Notices:

- ▶ Representation according to DIN ISO 1219-1. Hydraulic interim positions are shown by dashes.
- ▶ Other symbols upon request.

Function, section

The 5-chamber directional valve type 5-WE is a solenoid-actuated directional spool valve with switching time increase. It controls the start, stop and direction of a flow. The directional valve basically consists of housing (1), one or two electronic solenoids (2), control spool (3), and the return springs (4).

In de-energized condition, the control spool (3) is held in the central position or in the initial position by the return springs (4) (except for valves without spring "O").

If the wet-pin electronic solenoid (2) is energized, the control spool (3) moves out of its rest position into the required end position. In this way, the required direction of flow according to the selected symbol is released.

After the electronic solenoid (2) has been switched off, the control spool (3) is pushed back into its central position or into its initial position (except for valves with "OF" detent and valves without type "O" spring).

A manual override (6) allows for the manual switching of the valve without solenoid energization.

To ensure proper functioning, make sure that the pressure chamber of the solenoid is filled with oil.

More functions see page 8.

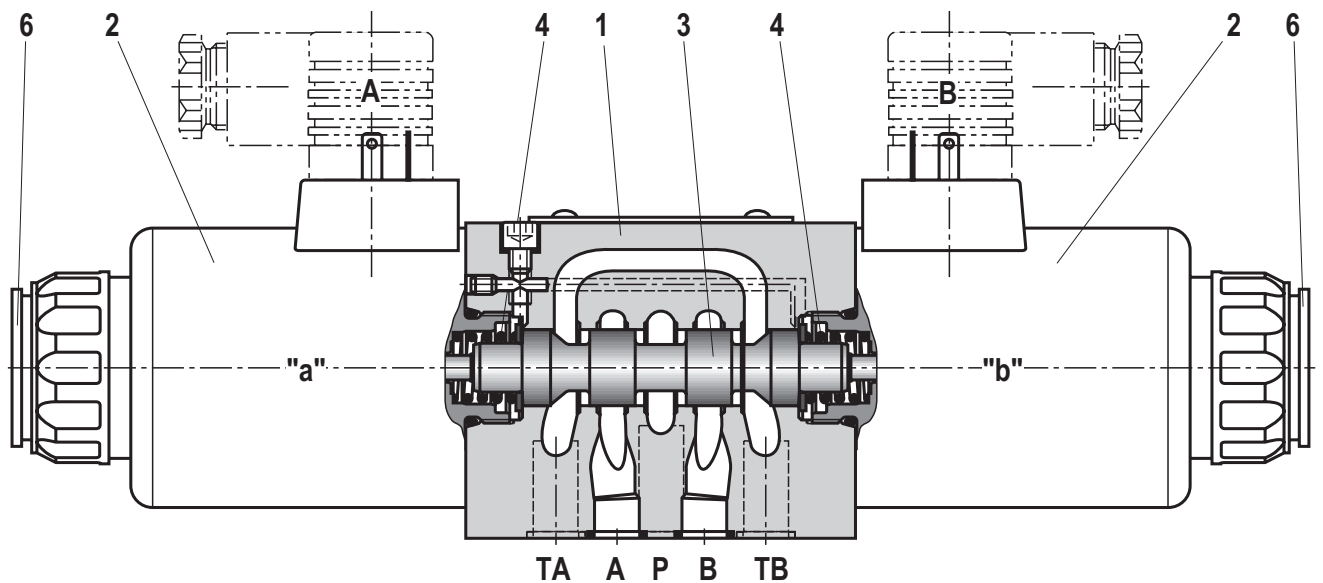

Type 5-4WE 10 ...

Throttle insert

Using a throttle insert (9) in channels P, A, B or T, the flow resistance at the valve can be increased. Its use is required when, due to prevailing operating conditions, flows occur during the switching processes, which exceed the performance limit of the valve.

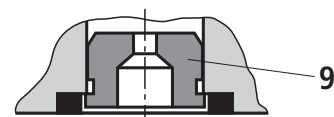

Function, section

Without spring return "O" (only possible with symbols A, C and D)

This version is a directional valve with 2 spool positions and 2 electronic solenoids **without** detent. The valve without spring return at the control spool (3) has no defined basic position in the de-energized condition.

Without spring return with "OF" detent (only possible with symbols A, C and D)

This version is a directional valve with 2 spool positions and 2 electronic solenoids **with** detent. The detents are used to fix the control spool (3) in the relevant spool position. During operation, continuous application of current to the electronic solenoid can thus be omitted which contributes to energy-efficient operation.

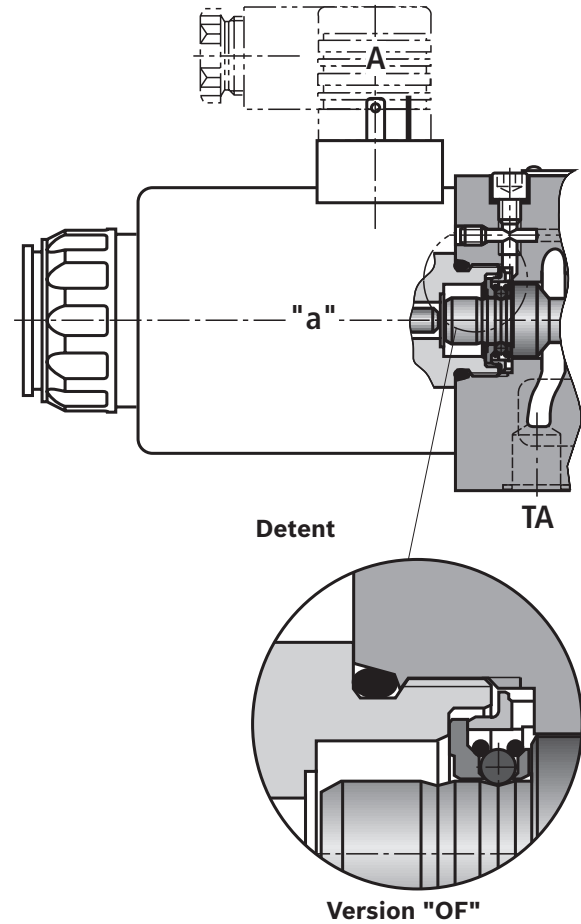

Notice:
 Pressure peaks in the tank line to two or several valves can result in unintended movement of the control spool in the case of valves with detent! We therefore recommend that separate return lines be provided or a check valve installed in the tank line.

Switching time increase

With the 5-chamber directional valve type 5-WE, the switching time can be delayed to 100 ms and more by means of a "C" throttle screw (7) or a selected "A0." orifice (8). In this connection, the switching time is pressure-, flow- and viscosity-dependent, specific to the installation. The switching time is influenced by means of a restriction (throttle or orifice) in the connection channel (5) between the two spring chambers in which the liquid volume is displaced from one spring chamber into the other in case of a switching process.

The T channels are separated from the spring chambers in order to achieve soft switching.

Notice:
 The adjustment spindle (10) may only be screwed out so that it protrudes from the nut by max. 3 mm.

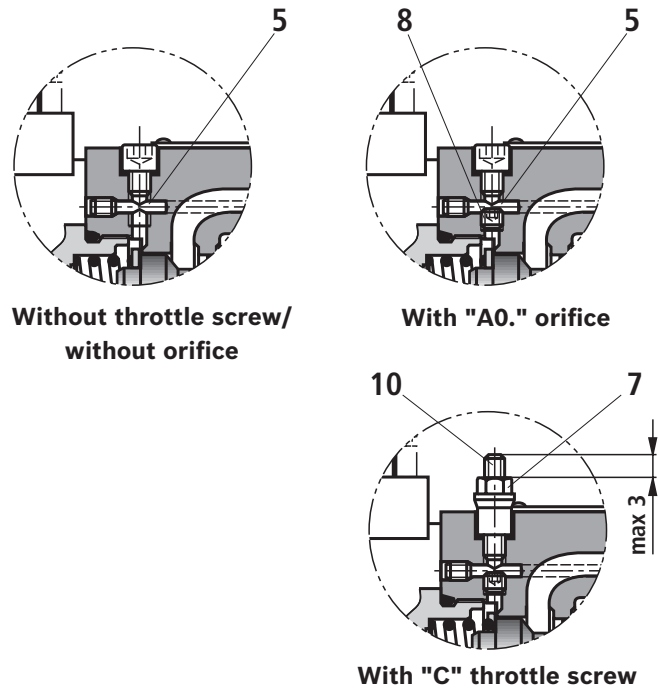

Technical data

(For applications outside these values, please consult us!)

general			
Weight	▶ Valve with one solenoid	kg [lbs]	3.9 [8.6]
	▶ Valve with two solenoids	kg [lbs]	5.5 [12.1]
Installation position			Any ¹⁾
Ambient temperature range	▶ Standard version	°C [°F]	-20 ... +70 [-4 ... +158] (NBR seals) -15 ... +70 [+5 ... +158] (FKM seals)
	▶ Version for HFC hydraulic fluid	°C [°F]	-20 ... +50 [-4 ... +122]
	▶ Low-temperature version ²⁾	°C [°F]	-40 ... +50 [-4 ... +122]
Storage temperature range			°C [°F] -20 ... +50 [-4 ... +122]
MTTF _d values according to EN ISO 13849			Years 300 (for further details see data sheet 08012)

hydraulic			
Maximum operating pressure ($p_p > p_A; p_B > p_T$)	▶ Port A, B, P	bar [psi]	350 [5076]; 420 [6091]
	▶ Port T	bar [psi]	210 [3050] Tank pressure (standard) With symbols A and B, port T must be used as leakage oil connection if the operating pressure exceeds the maximum admissible tank pressure.
Maximum flow		l/min [US gpm]	150 [39.6]
Flow cross-section (spool position 0)	▶ Symbol Q	mm ²	Approx. 6 % of nominal cross-section
	▶ Symbol W	mm ²	Approx. 3 % of nominal cross-section
Hydraulic fluid			See table below
Hydraulic fluid temperature range (at the valve working ports)		°C [°F]	-20 ... +80 [-4 ... +176] (NBR seals) -15 ... +80 [+5 ... +176] (FKM seals) -20 ... +50 [-4 ... +122] (HFC hydraulic fluid) -40 ... +50 [-4 ... +122] (Low-temperature version)
Viscosity range		mm ² /s [SUS]	2.8 ... 500 [35 ... 2320]
Maximum admissible degree of contamination of the hydraulic fluid cleanliness class according to ISO 4406 (c)			Class 20/18/15 ³⁾

Hydraulic fluid	Classification	Suitable sealing materials	Standards	Data sheet
Mineral oils	HL, HLP, HLPD, HVLP, HVLPD	NBR, FKM	DIN 51524	90220
Bio-degradable	▶ insoluble in water	HETG	ISO 15380	90221
		HEES		
	▶ soluble in water	HEPG	ISO 15380	
Flame-resistant	▶ water-free	HFDU, HFDR	ISO 12922	90222
	▶ containing water	HFC (Fuchs Hydrotherm 46M, Petrofer Ultra Safe 620)	ISO 12922	90223



Important information on hydraulic fluids:

- ▶ For more information and data on the use of other hydraulic fluids, please refer to the data sheets above or contact us!
- ▶ There may be limitations regarding the technical valve data (temperature, pressure range, life cycle, maintenance intervals, etc.)!
- ▶ The flash point of the hydraulic fluid used must be 40 K higher than the maximum solenoid surface temperature.

▶ Flame-resistant – containing water:

- Maximum pressure differential per control edge 50 bar
- Pressure pre-loading at the tank port > 20 % of the pressure differential, otherwise increased cavitation
- Life cycle as compared to operation with mineral oil HL, HLP 50 to 100 %

- ▶ **Bio-degradable and flame-resistant:** When using hydraulic fluids that are simultaneously zinc-soluble, zinc may accumulate (700 mg zinc per pole tube).

¹⁾ With suspended installation, higher sensitivity to contamination. Horizontal installation is recommended.

²⁾ In case of use at low temperatures, see project planning information on page 20.

³⁾ The cleanliness classes specified for the components must be adhered to in hydraulic systems. Effective filtration prevents faults and at the same time increases the life cycle of the components. Available filters can be found at www.boschrexroth.com/filter.

Technical data

(For applications outside these values, please consult us!)

electric						
Voltage type		Direct voltage		Alternating voltage		
Nominal voltage according to VDE 0580 (ordering code see page 2 and 11)		V	12, 24, 26, 48, 96, 110, 125, 180, 205, 220	only possible with rectifier ⁴⁾		
Voltage tolerance (nominal voltage)		%	±10			
Nominal power according to VDE 0580		W	40 ⁵⁾			
Duty cycle		%	100 (S1 according to VDE 0580)			
Switching time ⁶⁾	▶ ON	Pressure change 5 %	ms	60 ... 104 ^{7; 8)}		
		Pressure change 95 %	ms	90 ... 165 ^{7; 8)}		
	▶ OFF	Pressure change 5 %	ms	12 ... 50	230 ... 330	
		Pressure change 95 %	ms	48 ... 104	250 ... 360	
Switching time according to ISO 6403 ⁹⁾	▶ ON	45 ... 60				
	▶ OFF			20 ... 30	250 ... 360	
Maximum switching frequency		1/h	15000	7200		
Protection class according to DIN EN 60529		See page 11				
Protection class according to VDE 0580		See page 11				
Maximum surface temperature of the coil ¹⁰⁾		°C [°F]	140 [284]			
Insulation class VDE 0580		F				
Electrical protection		Every solenoid must be protected individually, using a suitable fuse with tripping characteristics K (inductive loads). The valve must be installed on a surface that is included in the equipotential bonding.				
Protective earthing conductor and screening		See connector pin assignment (CE-compliant installation) page 11				
Conformity		CE according to Low-Voltage Directive 2006/95/EC tested according to DIN EN 60204-1 (VDE0113-1): 2010-05 and DIN VDE 0580: 2000-07				

- 4) ▶ Mating connectors with rectifier see page 20.
▶ Possible voltages see page 3.
▶ Rectifiers must comply with the relevant standards as well as the coil performance data!
- 5) Reduction of the nominal power by approx. 40 % if a 24 V-coil with connector switching amplifier type VT-SSBA1-PWM-1X/V002/5 is used (separate order, material no. **R901290194**, see page 20 and data sheet 30362).
- 6) Measured with flow, 80 % performance limit, horizontal installation position and without switching time increase.
- 7) Not with symbols A and B.
- 8) Reduction of the switching time by approx. 50 % if a 12 V-coil with connector switching amplifier type VT-SSBA1-PWM-1X/V001/5 is used (separate order, material no. **R901265633**, see page 20 and data sheet 30362).
- 9) Measured without flow.
- 10) Possible surface temperature > 50 °C, provide contact protection.

 **Electrical connections** see page 11.

 **Notices:**

- ▶ The solenoid coils must not be painted.
- ▶ Actuation of the manual override is only possible up to a tank pressure of approx. 50 bar [725 psi]. Avoid damage to the bore of the manual override! (Special tool for the operation, separate order, material no. **R900024943**). When the manual override is blocked, actuation of the opposite solenoid must be ruled out!
- ▶ The simultaneous actuation of 2 solenoids of one valve must be ruled out!
- ▶ Use cables that are approved for an working temperature above 105 °C [221 °F].
- ▶ When solenoid coils are switched off, voltage peaks result which may cause faults or damage in the connected control electronics. The user has to provide for a suitable circuit for limiting the voltage peaks. It must be noted that a diode switched in an antiparallel form extends the switching off time.
- ▶ Valves with individual connection and supply voltage 12 V or 24 V can be operated with twice the voltage for reducing the switching time. For this purpose, the voltage has to be reduced to the nominal valve voltage after 100 ms by means of pulse width modulation. The maximum admissible switching frequency is 5 1/s.
- ▶ If the standard environmental conditions according to VDE 0580 cannot be provided, the valve must be especially protected!