

RELION® 615 SERIES

Voltage Protection and Control

REU615

Product Guide



Contents

1. Description.....	3	17. Inputs and outputs.....	14
2. Standard configurations.....	3	18. Station communication.....	15
3. Protection functions.....	7	19. Technical data.....	20
4. Application.....	7	20. Local HMI.....	42
5. Supported ABB solutions.....	9	21. Mounting methods.....	43
6. Control.....	11	22. Relay case and plug-in unit.....	43
7. Measurements.....	12	23. Selection and ordering data.....	43
8. Disturbance recorder.....	12	24. Accessories and ordering data.....	44
9. Event log.....	12	25. Tools.....	45
10. Recorded data.....	12	26. Cyber security.....	46
11. Condition monitoring	13	27. Terminal diagrams.....	47
12. Trip-circuit supervision.....	13	28. Certificates.....	49
13. Self-supervision.....	13	29. References.....	49
14. Fuse failure supervision.....	14	30. Functions, codes and symbols.....	50
15. Current circuit supervision.....	14	31. Document revision history.....	53
16. Access control.....	14		

Disclaimer

The information in this document is subject to change without notice and should not be construed as a commitment by ABB. ABB assumes no responsibility for any errors that may appear in this document.

© Copyright 2018 ABB.

All rights reserved.

Trademarks

ABB and Relion are registered trademarks of the ABB Group. All other brand or product names mentioned in this document may be trademarks or registered trademarks of their respective holders.

Voltage Protection and Control	1MRS757058 K
REU615	
Product version: 5.0 FP1	Issued: 2018-12-20
	Revision: K

1. Description

The voltage protection and control relay REU615 is available in two standard configurations, denoted A and B. Configuration A is preadapted for voltage and frequency-based protection schemes in utility and industrial power systems and distribution systems including networks with distributed power generation. The B configuration is designed for automatic voltage regulation of power transformers equipped with an on-load tap changer. Both configurations also feature additional CB control, measuring and supervising functions. REU615 is a member of ABB's Relion® product family and part of its 615 protection and control product series. The 615 series relays are characterized by their compactness and withdrawable-unit design.

Re-engineered from the ground up, the 615 series has been designed to unleash the full potential of the IEC 61850 standard for communication and interoperability between substation automation devices. Once the standard configuration relay has been given the application-specific settings, it can directly be put into service.

The 615 series relays support a range of communication protocols including IEC 61850 with Edition 2 support, process bus according to IEC 61850-9-2 LE, IEC 60870-5-103,

Modbus® and DNP3. Profibus DPV1 communication protocol is supported by using the protocol converter SPA-ZC 302.

2. Standard configurations

REU615 is available in two standard configurations. The standard signal configuration can be altered by means of the signal matrix or the graphical application functionality of the Protection and Control IED Manager PCM600. Further, the application configuration functionality of PCM600 supports the creation of multi-layer logic functions using various logical elements, including timers and flip-flops. By combining protection functions with logic function blocks, the relay configuration can be adapted to user-specific application requirements.

The relay is delivered from the factory with default connections described in the functional diagrams for binary inputs, binary outputs, function-to-function connections and alarm LEDs. Some of the supported functions in REU615 must be added with the Application Configuration tool to be available in the Signal Matrix tool and in the relay. The positive measuring direction of directional protection functions is towards the outgoing feeder.

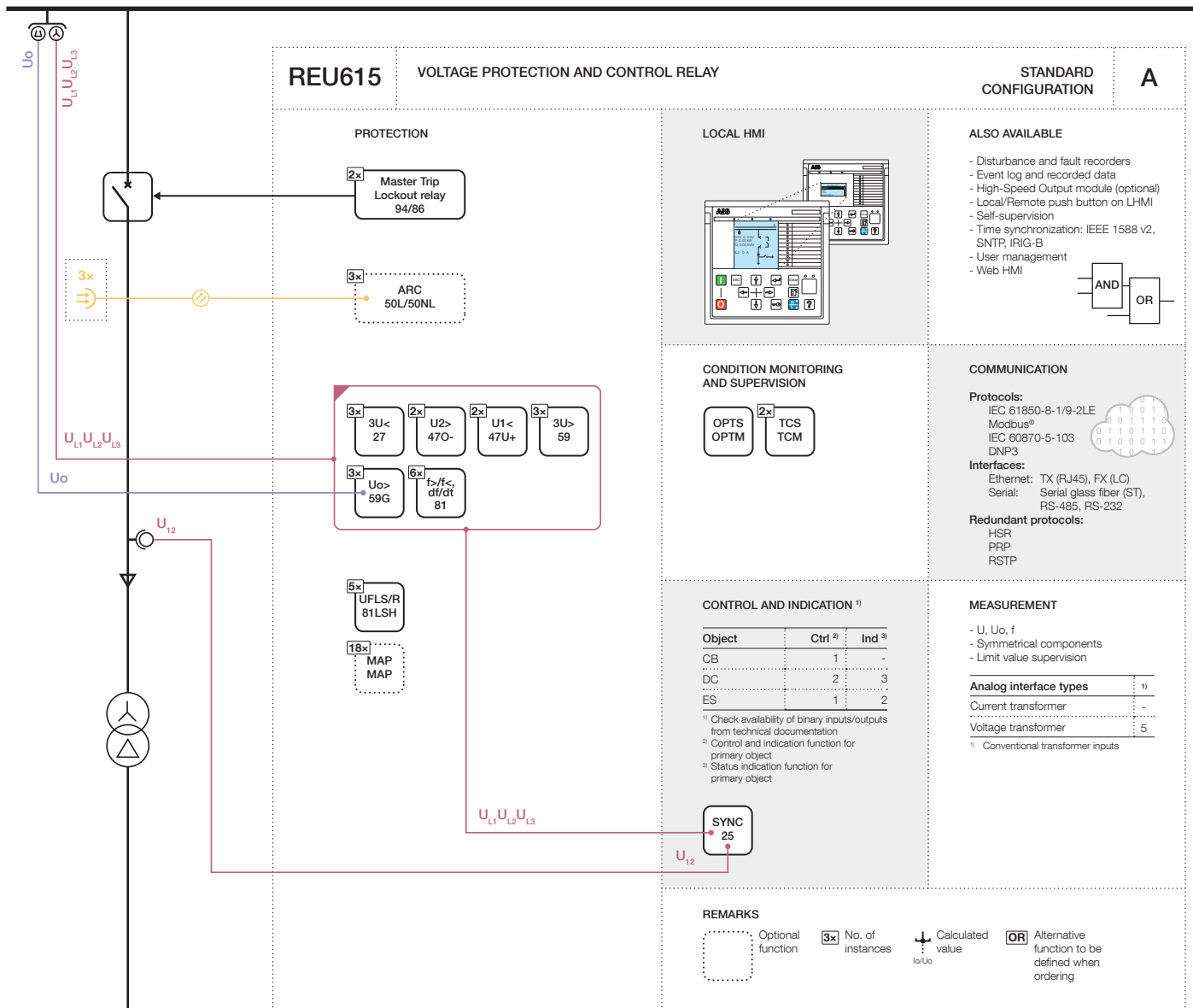

Figure 1. Functionality overview for standard configuration A

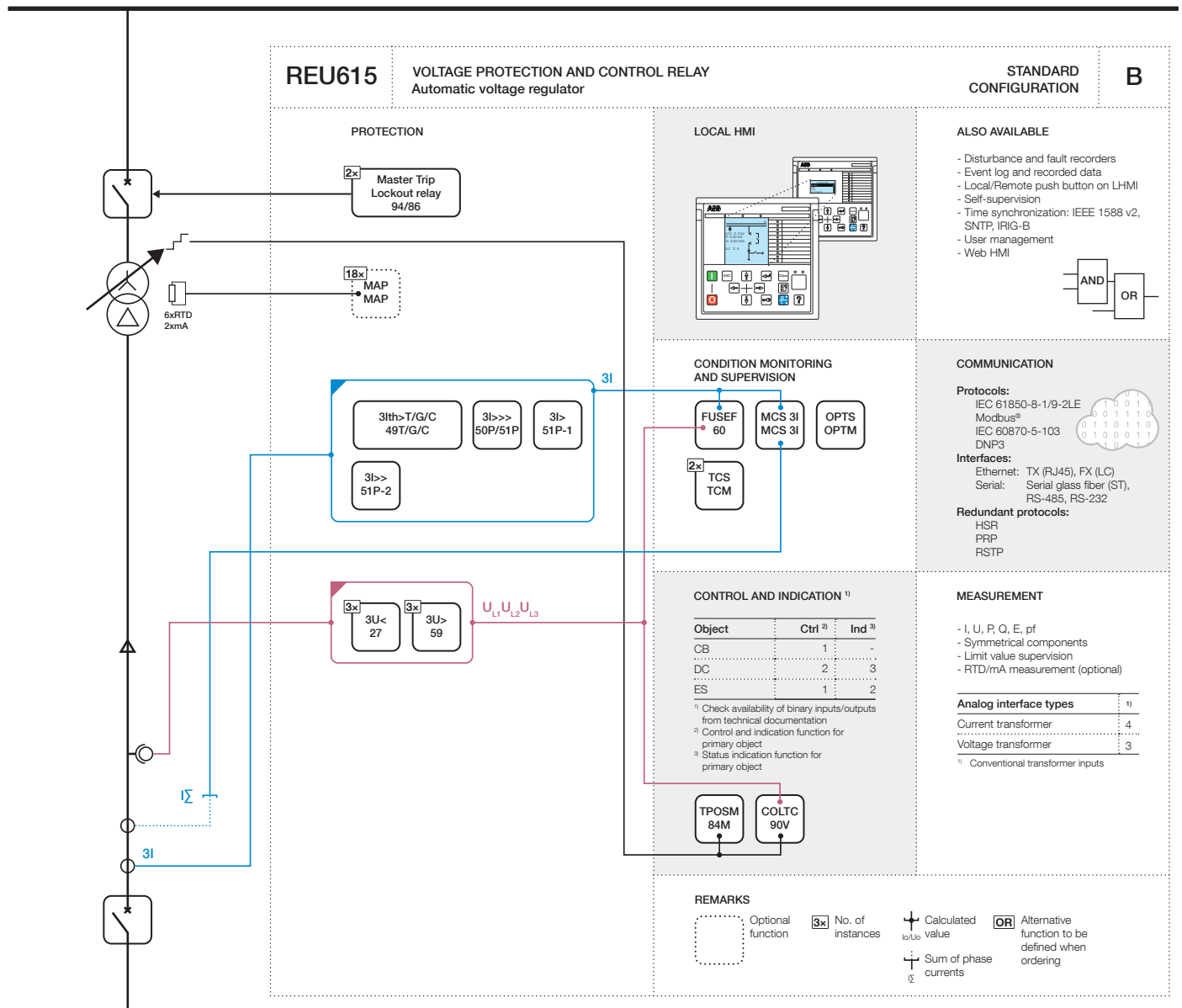

Figure 2. Functionality overview for standard configuration B

Table 1. Standard configurations

Description	Std.conf.
Voltage and frequency protection, synchro-check and load-shedding	A
Automatic voltage regulator	B

Table 2. Supported functions

Function	IEC 61850	A	B
Protection			
Three-phase non-directional overcurrent protection, low stage	PHLPTOC		1
Three-phase non-directional overcurrent protection, high stage	PHHPTOC		1
Three-phase non-directional overcurrent protection, instantaneous stage	PHIPTOC		1
Residual overvoltage protection	ROVPTOV	3	
Three-phase undervoltage protection	PHPTUV	3	3
Three-phase overvoltage protection	PHPTOV	3	3
Positive-sequence undervoltage protection	PSPTUV	2	
Negative-sequence overvoltage protection	NSPTOV	2	
Frequency protection	FRPFRQ	6	
Three-phase thermal overload protection, two time constants	T2PTTR		1
Master trip	TRPPTRC	2	2
Arc protection	ARCSARC	(3) ¹⁾	
Multipurpose protection	MAPGAPC	18	18
Load-shedding and restoration	LSHDPFRQ	5	
Control			
Circuit-breaker control	CBXCBR	1	1
Disconnecter control	DCXSWI	2	2
Earthing switch control	ESXSWI	1	1
Disconnecter position indication	DCSXSWI	3	3
Earthing switch indication	ESSXSWI	2	2
Tap changer position indication	TPOSYLTC		1
Tap changer control with voltage regulator	OLATCC		1
Synchronism and energizing check	SECRSYN	1	
Condition monitoring and supervision			
Trip circuit supervision	TCSSCBR	2	2
Current circuit supervision	CCSPVC		1
Fuse failure supervision	SEQSPVC		1
Runtime counter for machines and devices	MDSOPT	1	1
Measurement			
Disturbance recorder	RDRE	1	1
Load profile record	LDPRLRC	1	1
Fault record	FLTRFRC	1	1
Three-phase current measurement	CMMXU		1
Sequence current measurement	CSMSQI		1
Three-phase voltage measurement	VMMXU	2	1
Residual voltage measurement	RESVMMXU	1	
Sequence voltage measurement	VSMSQI	1	1
Three-phase power and energy measurement	PEMMXU		1
RTD/mA measurement	XRGGIO130		(1)
Frequency measurement	FMMXU	1	
IEC 61850-9-2 LE sampled value sending ²⁾³⁾	SMVSENDER	(1)	(1)
IEC 61850-9-2 LE sampled value receiving (voltage sharing) ²⁾³⁾	SMVRCV	(1)	(1)
Other			
Minimum pulse timer (2 pcs)	TPGAPC	4	4
Minimum pulse timer (2 pcs, second resolution)	TPSGAPC	1	1
Minimum pulse timer (2 pcs, minute resolution)	TPMGAPC	1	1
Pulse timer (8 pcs)	PTGAPC	2	2
Time delay off (8 pcs)	TOFGAPC	4	4
Time delay on (8 pcs)	TONGAPC	4	4
Set-reset (8 pcs)	SRGAPC	4	4
Move (8 pcs)	MVGAPC	2	2
Generic control point (16 pcs)	SPCGAPC	2	2

Table 2. Supported functions, continued

Function	IEC 61850	A	B
Analog value scaling (4 pcs)	SCA4GAPC	4	4
Integer value move (4 pcs)	MVI4GAPC	1	1

1, 2, ... = Number of included instances. The instances of a protection function represent the number of identical protection function blocks available in the standard configuration.

() = optional

- 1) Light only
 2) Available only with IEC 61850-9-2
 3) Available only with COM0031-0037

3. Protection functions

Standard configuration A is intended for busbar voltage supervision, load shedding (disconnection) and restoration (reconnection) applications. It is also used for overfrequency and underfrequency protection of power generators and for other AC equipment such as capacitor banks requiring three-phase overvoltage protection, three-phase undervoltage protection, residual overvoltage protection, positive-sequence undervoltage protection, negative-sequence overvoltage protection and frequency supervision.

The integrated load shedding and restoration functionality offers five instances for disconnection and reconnection of less important loads in network overload situations. The five instances enable the connected feeders to be more thoroughly prioritized and grouped thus facilitating the securing of critical applications.

If the restoration process is coordinated by an automation system or process control system, the relay's load shedding and restoration function can send a signal to the system when the prerequisites for network restoration are fulfilled.

Enhanced with optional hardware and software, standard configuration A also features three light detection channels for arc fault detection in the measurement cubicle or busbar compartment of metal-enclosed switchgear. The arc-fault detection sensor interface is available on the optional communication module.

When an arc arises, the detection signal is sent to the protection relay(s) of the incoming feeder(s) as a binary signal using either hardwired signalling or horizontal GOOSE messaging. By simultaneous utilization of the overcurrent condition of the incoming feeder protection relay and the received arc detection signal, the circuit breakers of the incoming feeders can selectively be tripped thus isolating the fault.

The arc detection and protection schemes of the relays increase personnel safety and limit material damage within the switchgear in an arc fault situation.

A binary input and output module can be selected as an option - having three high speed binary outputs (HSO) it further

decreases the total operate time with typically 4...6 ms compared to the normal power outputs.

Standard configuration B is intended for automatic voltage regulation of power transformers equipped with an on-load tap changer. It also features three-stage three-phase non-directional overcurrent protection as well as three-phase undervoltage and overvoltage protection. The relay also incorporates a thermal overload protection function, which supervises the thermal stress of the transformer windings to prevent premature aging of the winding's insulation.

The use of the multipurpose protection function requires that the optional RTD/mA input module has been chosen at the time of ordering. The multi-purpose protection function enables protection based on analog values from the relays' RTD/mA input module, or from other devices using analog horizontal GOOSE messaging. The protection function includes three instances and the used analog values may, for example, consist of temperature, current, voltage or pressure values. By using the analog values, the set limit values and the timers of the protection function can be set to operate when the input values are below or exceeds the set values.

4. Application

The standard configuration A is intended to be used in medium voltage switchgear supplied with a dedicated voltage measurement cubicle. The A configuration provides busbar overvoltage and undervoltage supervision, network residual overvoltage supervision and frequency supervision. REU615 offers the functionality needed to provide load-shedding or generation rejection to enhance network stability. In generator and motor applications REU615 provides supplementary protection by detecting any deviation from the permitted frequency and voltage values. An integrated synchrocheck function ensures a synchronized connection of the equipment into the network. In distribution networks containing distributed power generation REU615 can be used for loss-of-mains (LOM) protection for single power generating units.

The standard configuration B including voltage regulation is intended for automatic and manual voltage regulation of power transformers equipped with motor driven on-load tap changers. In small substations with a single power transformer, REU615

can be used for load-side voltage regulation. For substations with two or more power transformers operating in parallel, three alternative voltage regulation principles are available, that is,

the master/follower principle, the negative reactance principle (NRP) and the minimizing circulating current (MCC) principle.

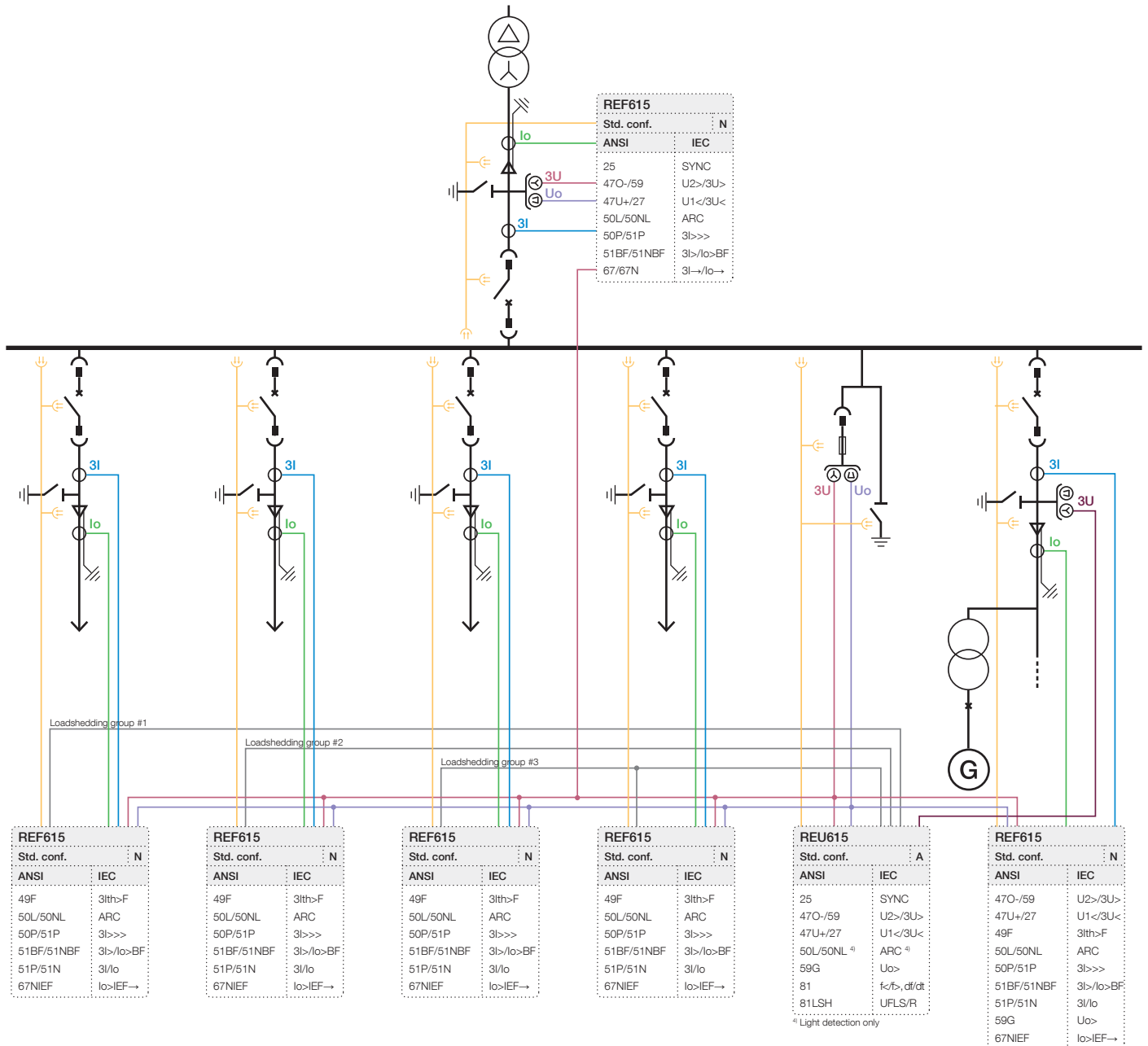

Figure 3. Busbar protection and supervision using REU615 with the standard configuration A

Busbar protection and supervision using REU615 with the standard configuration A is illustrated in Figure 3. The arc protection schemes of REU615 and REF615 are employed for the busbar protection of the voltage measurement bay and related parts of the busbar. Apart from the busbar protection and supervision, REU615 is utilized for centralized load-

shedding (disconnection) and restoration (reconnection) of one of the outgoing feeders. The synchrocheck and energizing check functions incorporated in REU615 are employed for ensuring a safe connection of the outgoing feeder, including distributed generation, to the network.

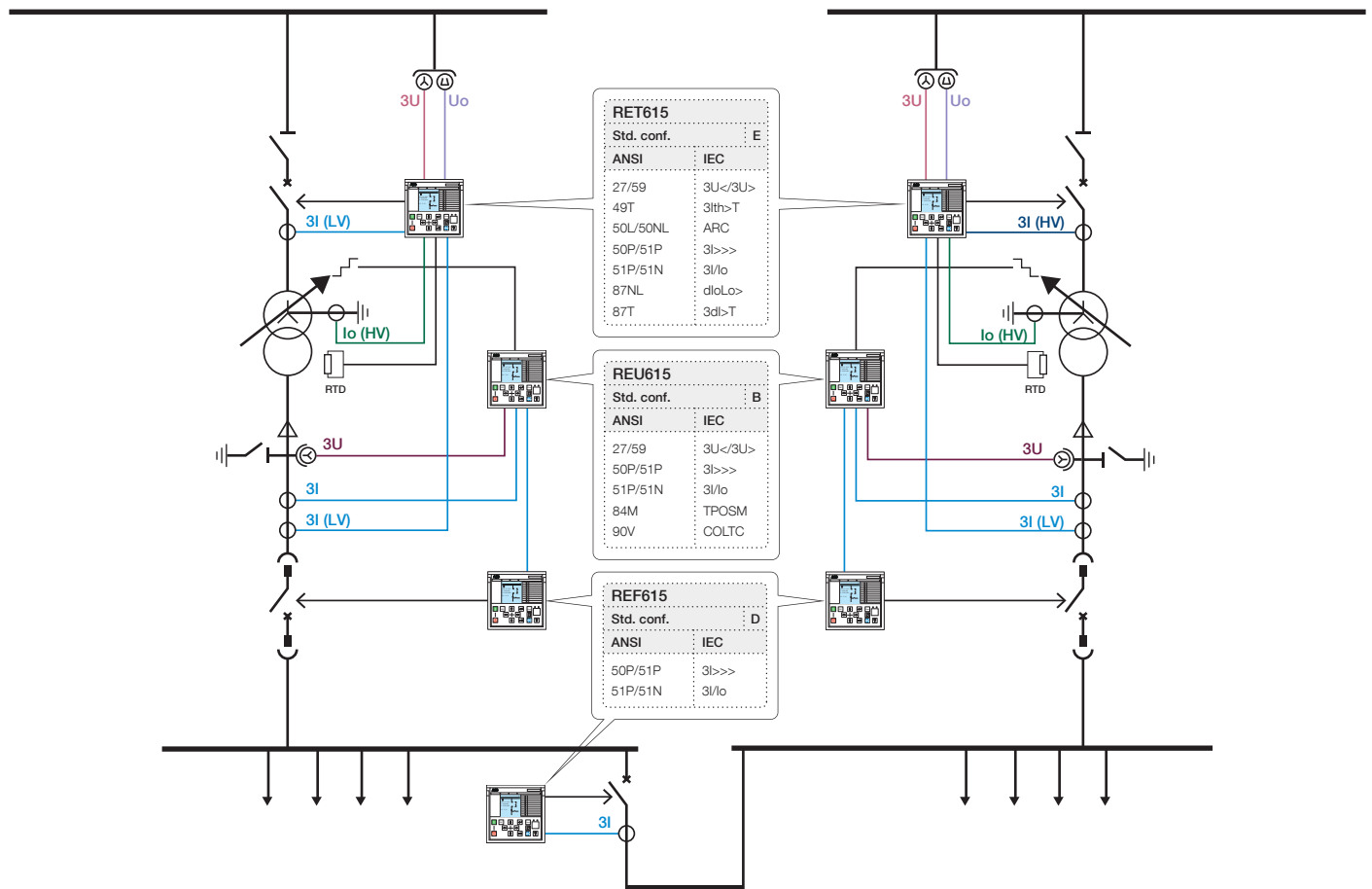

Figure 4. Tap changer control and power transformer thermal overload protection using REU615 with the standard configuration B

Figure 4 illustrates tap changer control and power transformer thermal overload protection using REU615 with the standard configuration B. The tap changer position information is received as a mA signal from the tap changer operation mechanism. The position value is sent to the transformer differential protection function of RET615 using GOOSE

messaging. The analog GOOSE messaging enables the tap changer control of the two parallel running power transformers. The RTD inputs complement the thermal overload protection by measuring the oil and ambient temperature of the power transformer.

5. Supported ABB solutions

The 615 series protection relays together with the Substation Management Unit COM600S constitute a genuine IEC 61850 solution for reliable power distribution in utility and industrial power systems. To facilitate the system engineering, ABB's relays are supplied with connectivity packages. The connectivity packages include a compilation of software and relay-specific information, including single-line diagram templates and a full relay data model. The data model includes event and parameter lists. With the connectivity packages, the relays can be readily configured using PCM600 and integrated with COM600S or the network control and management system MicroSCADA Pro.

The 615 series relays offer native support for IEC 61850 Edition 2 also including binary and analog horizontal GOOSE messaging. In addition, process bus with the sending of sampled values of analog currents and voltages and the receiving of sampled values of voltages is supported. Compared to traditional hard-wired, inter-device signaling, peer-to-peer communication over a switched Ethernet LAN offers an advanced and versatile platform for power system protection. Among the distinctive features of the protection system approach, enabled by the full implementation of the IEC 61850 substation automation standard, are fast communication capability, continuous supervision of the protection and communication system's integrity, and an inherent flexibility regarding reconfiguration and upgrades. This

protection relay series is able to optimally utilize interoperability provided by the IEC 61850 Edition 2 features.

At substation level, COM600S uses the data content of the bay-level devices to enhance substation level functionality. COM600S features a Web browser-based HMI, which provides a customizable graphical display for visualizing single-line mimic diagrams for switchgear bay solutions. The SLD feature is especially useful when 615 series relays without the optional single-line diagram feature are used. The Web HMI of COM600S also provides an overview of the whole substation, including relay-specific single-line diagrams, which makes information easily accessible. Substation devices and processes can also be remotely accessed through the Web HMI, which improves personnel safety.

In addition, COM600S can be used as a local data warehouse for the substation's technical documentation and for the network data collected by the devices. The collected network

data facilitates extensive reporting and analyzing of network fault situations by using the data historian and event handling features of COM600S. The historical data can be used for accurate monitoring of process and equipment performance, using calculations based on both real-time and historical values. A better understanding of the process dynamics is achieved by combining time-based process measurements with production and maintenance events.

COM600S can also function as a gateway and provide seamless connectivity between the substation devices and network-level control and management systems, such as MicroSCADA Pro and System 800xA.

GOOSE Analyzer interface in COM600S enables the following and analyzing the horizontal IEC 61850 application during commissioning and operation at station level. It logs all GOOSE events during substation operation to enable improved system supervision.

Table 3. Supported ABB solutions

Product	Version
Substation Management Unit COM600S	4.0 SP1 or later
	4.1 or later (Edition 2)
MicroSCADA Pro SYS 600	9.3 FP2 or later
	9.4 or later (Edition 2)
System 800xA	5.1 or later

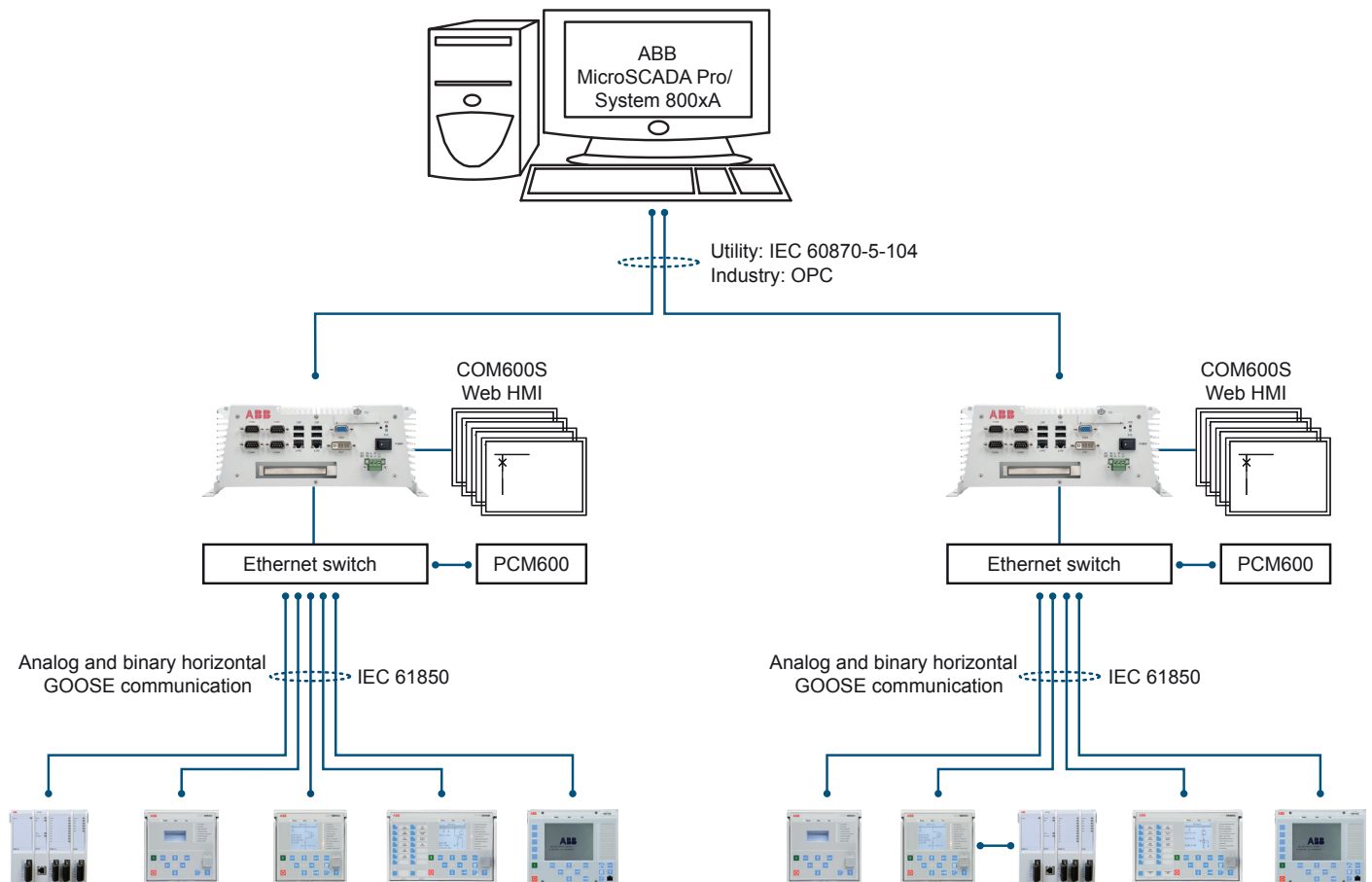

Figure 5. ABB power system example using Relion relays, COM600S and MicroSCADA Pro/System 800xA

6. Control

REU615 integrates functionality for the control of a circuit breaker via the front panel HMI or by means of remote controls. In addition to the circuit breaker control the relay features two control blocks which are intended for motor-operated control of disconnectors or circuit breaker truck and for their position indications.

Further, the relay offers one control block which is intended for motor-operated control of one earthing switch control and its position indication.

Two physical binary inputs and two physical binary outputs are needed in the relay for each controllable primary device taken into use. The number of unused binary inputs and binary outputs varies depending on the chosen standard configuration of the relay. Some standard configurations offer optional hardware modules that increase the number of available binary inputs and outputs.

If the amount of available binary inputs or outputs of the chosen standard configuration is not sufficient, the standard

configuration can be modified to release some binary inputs or outputs which have originally been configured for other purposes, when applicable, or an external input or output module, for example, RIO600 can be integrated to the relay. The binary inputs and outputs of the external I/O module can be used for the less time critical binary signals of the application. The integration enables releasing of some initially reserved binary inputs and outputs of the relay in the standard configuration.

The suitability of the binary outputs of the relay which have been selected for controlling of primary devices should be carefully verified, for example the make and carry, as well as the breaking capacity. If the requirements for the control-circuit of the primary device are not met, the use of external auxiliary relays should be considered.

The optional large graphical LCD of the relay's HMI includes a single-line diagram (SLD) with position indication for the relevant primary devices. Interlocking schemes required by the

application are configured using the signal matrix or the application configuration functionality of PCM600.

Standard configuration A incorporates a synchrocheck function to ensure that the voltage, phase angle and frequency on either side of an open circuit breaker satisfy the conditions for safe interconnection of two networks. Standard configuration B includes functionality for controlling the voltage on the load side of the power transformer. Based on the measured values the relay sends control commands to the tap changer thus enabling automatic voltage regulation.

7. Measurements

The offered measurement functions depend on the chosen standard configuration. Standard configuration A offers phase voltage, residual voltage and voltage phase sequence component measurement. In addition, the standard configuration includes frequency measurement.

Relays with standard configuration B measure the three phase currents and the symmetrical components of the currents, the phase voltages, the symmetrical components of the voltage and the phase unbalance value based on the ratio between the negative phase-sequence and positive phase-sequence current. Further, the relay offers three-phase power and energy measurement including power factor. In addition, the relay calculates the demand value of current over a user-selectable pre-set time frame and the thermal overload of the protected object.

For standard configuration B, RTD/mA inputs are offered as an option. By means of the optional RTD/mA module the relay can measure up to eight analog signals such as temperature, pressure and tap changer position values via the six RTD inputs or the two mA inputs using transducers.

The measured values can be accessed via the local HMI or remotely via the communication interface of the relay. The values can also be accessed locally or remotely using the Web HMI.

The relay is provided with a load profile recorder. The load profile feature stores the historical load data captured at a periodical time interval (demand interval). The records are in COMTRADE format.

8. Disturbance recorder

The relay is provided with a disturbance recorder featuring up to 12 analog and 64 binary signal channels. The analog channels

can be set to record either the waveform or the trend of the currents and voltages measured.

The analog channels can be set to trigger the recording function when the measured value falls below or exceeds the set values. The binary signal channels can be set to start a recording either on the rising or the falling edge of the binary signal or on both.

By default, the binary channels are set to record external or internal relay signals, for example, the start or trip signals of the relay stages, or external blocking or control signals. Binary relay signals, such as protection start and trip signals, or an external relay control signal via a binary input, can be set to trigger the recording. Recorded information is stored in a nonvolatile memory and can be uploaded for subsequent fault analysis.

9. Event log

To collect sequence-of-events information, the relay has a non-volatile memory capable of storing 1024 events with the associated time stamps. The non-volatile memory retains its data even if the relay temporarily loses its auxiliary supply. The event log facilitates detailed pre- and post-fault analyses of feeder faults and disturbances. The considerable capacity to process and store data and events in the relay facilitates meeting the growing information demand of future network configurations.

The sequence-of-events information can be accessed either via local HMI or remotely via the communication interface of the relay. The information can also be accessed locally or remotely using the Web HMI.

10. Recorded data

The relay has the capacity to store the records of the 128 latest fault events. The records can be used to analyze the power system events. Each record includes, for example, current, voltage and angle values and a time stamp. The fault recording can be triggered by the start or the trip signal of a protection block, or by both. The available measurement modes include DFT, RMS and peak-to-peak. Fault records store relay measurement values at the moment when any protection function starts. In addition, the maximum demand current with time stamp is separately recorded. The records are stored in the non-volatile memory.

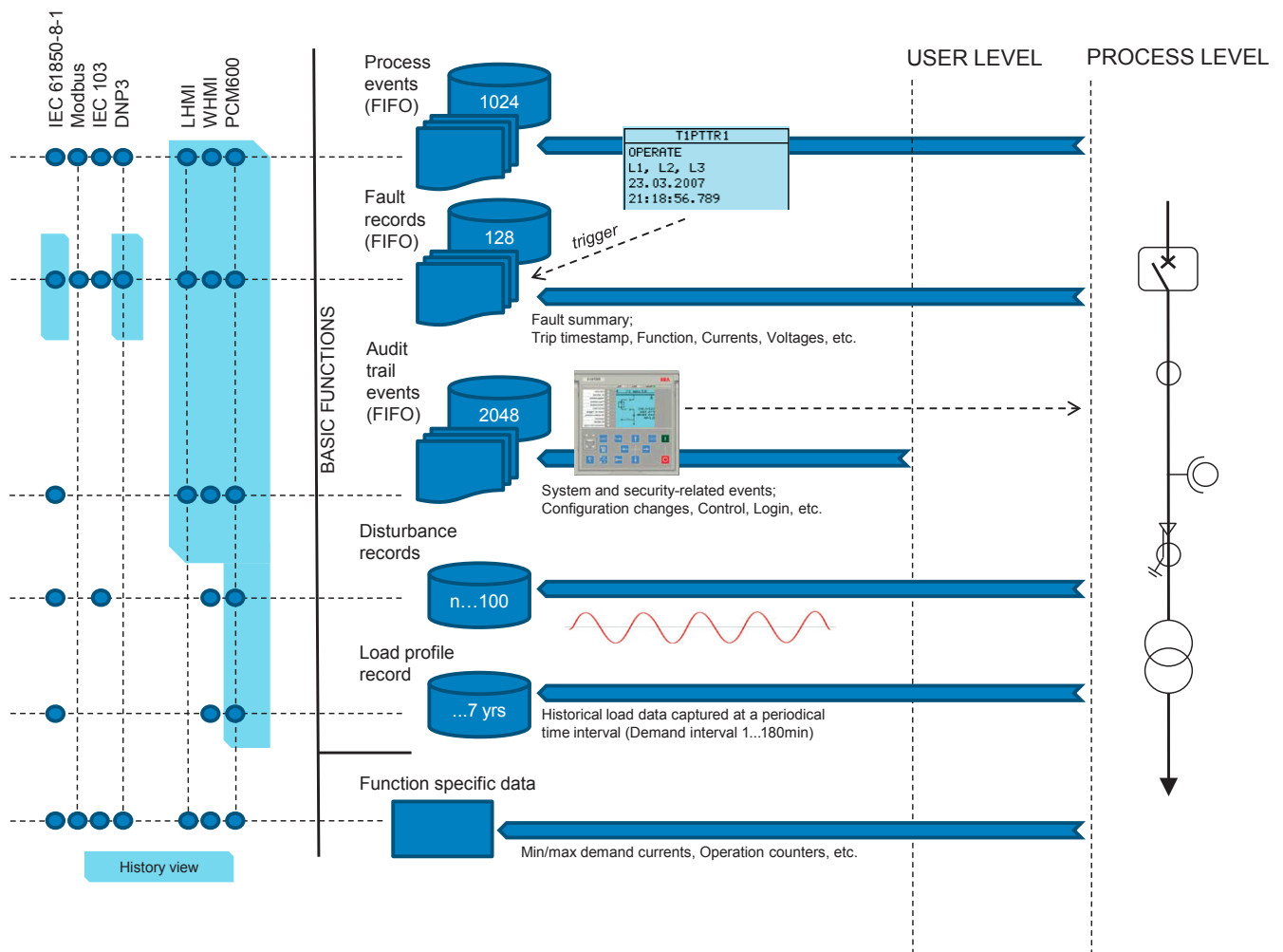

Figure 6. Recording and event capabilities overview

11. Condition monitoring

The condition monitoring functions of the relay constantly monitor the performance and the condition of the circuit breaker. The monitoring comprises the spring charging time, SF6 gas pressure, the travel time and the inactivity time of the circuit breaker.

The monitoring functions provide operational circuit breaker history data, which can be used for scheduling preventive circuit breaker maintenance.

In addition, the relay includes a runtime counter for monitoring of how many hours a protected device has been in operation thus enabling scheduling of time-based preventive maintenance of the device.

12. Trip-circuit supervision

The trip-circuit supervision continuously monitors the availability and operability of the trip circuit. It provides open-circuit monitoring both when the circuit breaker is in its closed and in its open position. It also detects loss of circuit-breaker control voltage.

13. Self-supervision

The relay's built-in self-supervision system continuously monitors the state of the relay hardware and the operation of the relay software. Any fault or malfunction detected is used for alerting the operator.

A permanent relay fault blocks the protection functions to prevent incorrect operation.

14. Fuse failure supervision

The fuse failure supervision detects failures between the voltage measurement circuit and the relay. The failures are detected either by the negative sequence-based algorithm or by the delta voltage and delta current algorithm. Upon the detection of a failure, the fuse failure supervision function activates an alarm and blocks voltage-dependent protection functions from unintended operation.

15. Current circuit supervision

Current circuit supervision is used for detecting faults in the current transformer secondary circuits. On detecting of a fault the current circuit supervision function activates an alarm LED and blocks certain protection functions to avoid unintended operation. The current circuit supervision function calculates the sum of the phase currents from the protection cores and compares the sum with the measured single reference current from a core balance current transformer or from separate cores in the phase current transformers.

16. Access control

To protect the relay from unauthorized access and to maintain information integrity, the relay is provided with a four-level, role-based authentication system with administrator-programmable individual passwords for the viewer, operator, engineer and administrator levels. The access control applies to the local HMI, the Web HMI and PCM600.

17. Inputs and outputs

Depending on the standard configuration selected, the relay is equipped with three phase-voltage inputs and one residual current input or three phase current inputs, one residual-current input and three phase voltage inputs.

The residual current input and the phase-current inputs are rated 1/5 A. The three phase-voltage inputs and the residual-voltage input covers the rated voltages 60-210 V. Both phase-to-phase voltages and phase-to-earth voltages can be connected.

The phase-current input 1 A or 5 A, the residual-current input 1 A or 5 A, and the rated voltage of the residual voltage input are selected in the relay software. In addition, the binary input thresholds 16...176 V DC are selected by adjusting the relay's parameter settings.

All binary input and output contacts are freely configurable with the signal matrix or application configuration functionality of PCM600.

As an option for standard configurations B the relay offers six RTD inputs and two mA inputs. By means of the optional RTD/mA module the relay can measure up to eight analog signals such as temperature, pressure and tap changer position values via the six RTD inputs or the two mA inputs using transducers. The values can, apart from measuring and monitoring purposes, be used for tripping and alarm purposes using the offered optional multipurpose protection functions.

Optionally for standard configuration A, a binary input and output module can be selected. It has three high speed binary outputs (HSO) and it decreases the total operate time with typically 4-6 ms compared to the normal power outputs.

See the Input/output overview table and the terminal diagrams for more information about the inputs and outputs.

Table 4. Input/output overview

Std. conf.	Order code digit		Analog channels		Binary channels		RTD	mA
	5-6	7-8	CT	VT	BI	BO		
A	EA	AD	-	5	12	4 PO + 6 SO	-	-
		FE	-	5	12	4 PO + 2 SO + 3 HSO	-	-
B	CA	BB	4	3	14	4 PO + 9 SO	-	-
	CC	AH	4	3	8	4 PO + 6 SO	6	2

18. Station communication

The relay supports a range of communication protocols including IEC 61850 Edition 2, IEC 61850-9-2 LE, IEC 60870-5-103, Modbus® and DNP3. Profibus DPV1 communication protocol is supported with using the protocol converter SPA-ZC 302. Operational information and controls are available through these protocols. However, some communication functionality, for example, horizontal communication between the relays, is only enabled by the IEC 61850 communication protocol.

The IEC 61850 protocol is a core part of the relay as the protection and control application is fully based on standard modelling. The relay supports Edition 2 and Edition 1 versions of the standard. With Edition 2 support, the relay has the latest functionality modelling for substation applications and the best interoperability for modern substations. It incorporates also the full support of standard device mode functionality supporting different test applications. Control applications can utilize the new safe and advanced station control authority feature.

The IEC 61850 communication implementation supports monitoring and control functions. Additionally, parameter settings, disturbance recordings and fault records can be accessed using the IEC 61850 protocol. Disturbance recordings are available to any Ethernet-based application in the standard COMTRADE file format. The relay supports simultaneous event reporting to five different clients on the station bus. The relay can exchange data with other devices using the IEC 61850 protocol.

The relay can send binary and analog signals to other devices using the IEC 61850-8-1 GOOSE (Generic Object Oriented Substation Event) profile. Binary GOOSE messaging can, for example, be employed for protection and interlocking-based protection schemes. The relay meets the GOOSE performance requirements for tripping applications in distribution substations, as defined by the IEC 61850 standard (<10 ms data exchange between the devices). The relay also supports the sending and receiving of analog values using GOOSE messaging. Analog GOOSE messaging enables easy transfer of analog measurement values over the station bus, thus facilitating for example the sending of measurement values between the relays when controlling parallel running transformers. In REU615, analog GOOSE messaging is employed in control schemes of parallel running transformers where measured values are exchanged between the relays.

The relay also supports IEC 61850 process bus by sending sampled values of analog currents and voltages and by receiving sampled values of voltages. With this functionality the galvanic interpanel wiring can be replaced with Ethernet communication. The measured values are transferred as sampled values using IEC 61850-9-2 LE protocol. The intended application for sampled values shares the voltages to other 615 series relays, having voltage based functions and 9-2 support. 615 relays with process bus based applications use IEEE 1588 for high accuracy time synchronization.

For redundant Ethernet communication, the relay offers either two optical or two galvanic Ethernet network interfaces. A third port with galvanic Ethernet network interface is also available. The third Ethernet interface provides connectivity for any other Ethernet device to an IEC 61850 station bus inside a switchgear bay, for example connection of a Remote I/O. Ethernet network redundancy can be achieved using the high-availability seamless redundancy (HSR) protocol or the parallel redundancy protocol (PRP) or a with self-healing ring using RSTP in managed switches. Ethernet redundancy can be applied to Ethernet-based IEC 61850, Modbus and DNP3 protocols.

The IEC 61850 standard specifies network redundancy which improves the system availability for the substation communication. The network redundancy is based on two complementary protocols defined in the IEC 62439-3 standard: PRP and HSR protocols. Both the protocols are able to overcome a failure of a link or switch with a zero switch-over time. In both the protocols, each network node has two identical Ethernet ports dedicated for one network connection. The protocols rely on the duplication of all transmitted information and provide a zero switch-over time if the links or switches fail, thus fulfilling all the stringent real-time requirements of substation automation.

In PRP, each network node is attached to two independent networks operated in parallel. The networks are completely separated to ensure failure independence and can have different topologies. The networks operate in parallel, thus providing zero-time recovery and continuous checking of redundancy to avoid failures.

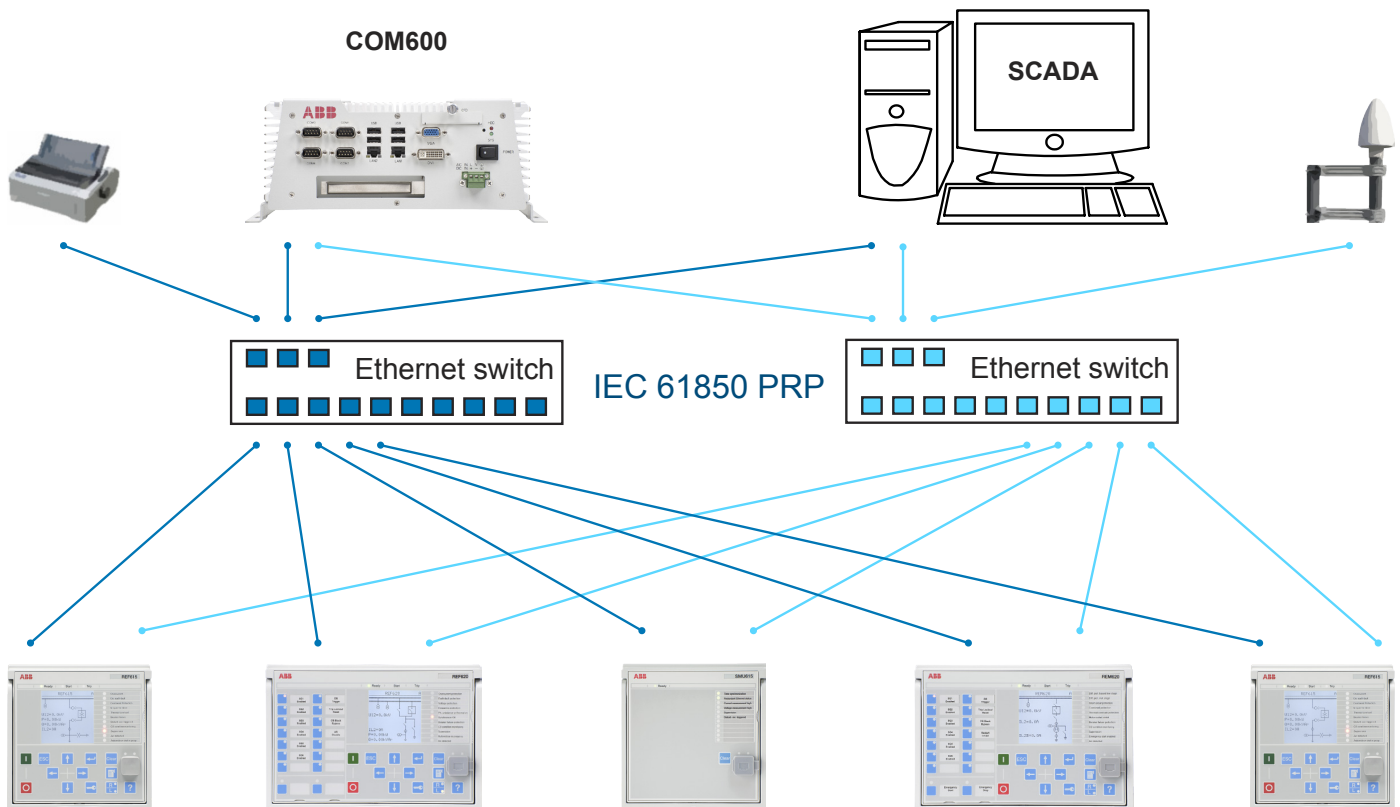

Figure 7. Parallel redundancy protocol (PRP) solution

HSR applies the PRP principle of parallel operation to a single ring. For each message sent, the node sends two frames, one through each port. Both the frames circulate in opposite directions over the ring. Every node forwards the frames it receives from one port to another to reach the next node. When the originating sender node receives the frame it sent, the

sender node discards the frame to avoid loops. The HSR ring with 615 series relays supports the connection of up to 30 relays. If more than 30 relays are to be connected, it is recommended to split the network into several rings to guarantee the performance for real-time applications.

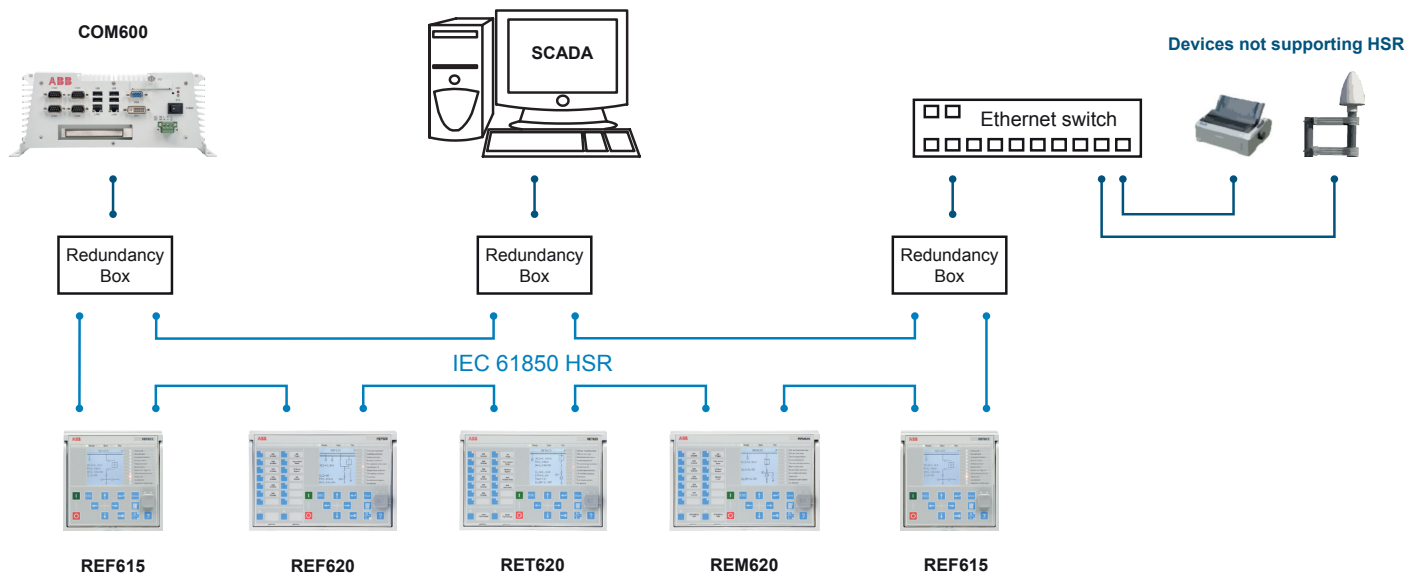

Figure 8. High availability seamless redundancy (HSR) solution

The choice between the HSR and PRP redundancy protocols depends on the required functionality, cost and complexity.

The self-healing Ethernet ring solution enables a cost-efficient communication ring controlled by a managed switch with standard Rapid Spanning Tree Protocol (RSTP) support. The managed switch controls the consistency of the loop, routes the data and corrects the data flow in case of a communication

switch-over. The relays in the ring topology act as unmanaged switches forwarding unrelated data traffic. The Ethernet ring solution supports the connection of up to 30 615 series relays. If more than 30 relays are to be connected, it is recommended to split the network into several rings. The self-healing Ethernet ring solution avoids single point of failure concerns and improves the reliability of the communication.

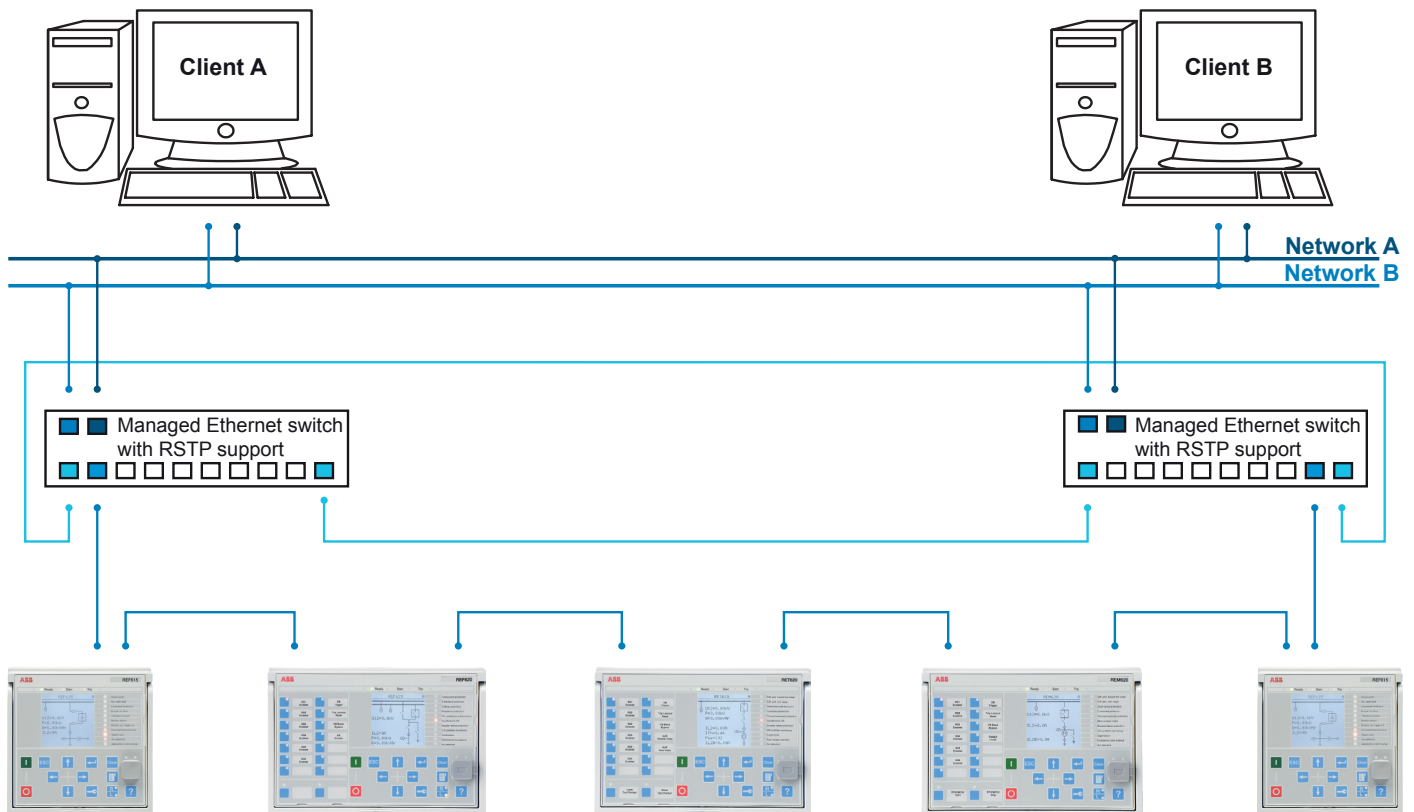

Figure 9. Self-healing Ethernet ring solution

All communication connectors, except for the front port connector, are placed on integrated optional communication modules. The relay can be connected to Ethernet-based communication systems via the RJ-45 connector (100Base-TX) or the fiber optic LC connector (100Base-FX). If connection to serial bus is required, the 9-pin RS-485 screw-terminal can be used. An optional serial interface is available for RS-232 communication.

Modbus implementation supports RTU, ASCII and TCP modes. Besides standard Modbus functionality, the relay supports retrieval of time-stamped events, changing the active setting group and uploading of the latest fault records. If a Modbus TCP connection is used, five clients can be connected to the relay simultaneously. Further, Modbus serial and Modbus TCP can be used in parallel, and if required both IEC 61850 and Modbus protocols can be run simultaneously.

The IEC 60870-5-103 implementation supports two parallel serial bus connections to two different masters. Besides basic standard functionality, the relay supports changing of the active setting group and uploading of disturbance recordings in IEC 60870-5-103 format. Further, IEC 60870-5-103 can be used at the same time with the IEC 61850 protocol.

DNP3 supports both serial and TCP modes for connection up to five masters. Changing of the active setting and reading fault

records are supported. DNP serial and DNP TCP can be used in parallel. If required, both IEC 61850 and DNP protocols can be run simultaneously.

615 series supports Profibus DPV1 with support of SPA-ZC 302 Profibus adapter. If Profibus is required the relay must be ordered with Modbus serial options. Modbus implementation includes SPA-protocol emulation functionality. This functionality enables connection to SPA-ZC 302.

When the relay uses the RS-485 bus for the serial communication, both two- and four wire connections are supported. Termination and pull-up/down resistors can be configured with jumpers on the communication card so external resistors are not needed.

The relay supports the following time synchronization methods with a time-stamping resolution of 1 ms.

Ethernet-based

- SNTP (Simple Network Time Protocol)

With special time synchronization wiring

- IRIG-B (Inter-Range Instrumentation Group - Time Code Format B)

REU615

Product version: 5.0 FP1

The relay supports the following high accuracy time synchronization method with a time-stamping resolution of 4 μ s required especially in process bus applications.

- PTP (IEEE 1588) v2 with Power Profile

The IEEE 1588 support is included in all variants having a redundant Ethernet communication module.

IEEE 1588 v2 features

- Ordinary Clock with Best Master Clock algorithm
- One-step Transparent Clock for Ethernet ring topology
- 1588 v2 Power Profile
- Receive (slave): 1-step/2-step
- Transmit (master): 1-step

- Layer 2 mapping
- Peer to peer delay calculation
- Multicast operation

Required accuracy of grandmaster clock is +/- 1 μ s. The relay can work as a master clock per BMC algorithm if the external grandmaster clock is not available for short term.

The IEEE 1588 support is included in all variants having a redundant Ethernet communication module.

In addition, the relay supports time synchronization via Modbus, DNP3 and IEC 60870-5-103 serial communication protocols.

Table 5. Supported station communication interfaces and protocols

Interfaces/Protocols	Ethernet		Serial	
	100BASE-TX RJ-45	100BASE-FX LC	RS-232/RS-485	Fiber optic ST
IEC 61850-8-1	•	•	-	-
IEC 61850-9-2 LE	•	•	-	-
MODBUS RTU/ASCII	-	-	•	•
MODBUS TCP/IP	•	•	-	-
DNP3 (serial)	-	-	•	•
DNP3 TCP/IP	•	•	-	-
IEC 60870-5-103	-	-	•	•

• = Supported

19. Technical data

Table 6. Dimensions

Description	Value	
Width	Frame	177 mm
	Case	164 mm
Height	Frame	177 mm (4U)
	Case	160 mm
Depth	201 mm (153 + 48 mm)	
Weight	Complete protection relay	4.1 kg
	Plug-in unit only	2.1 kg

Table 7. Power supply

Description	Type 1	Type 2
Nominal auxiliary voltage U_n	100, 110, 120, 220, 240 V AC, 50 and 60 Hz	24, 30, 48, 60 V DC
	48, 60, 110, 125, 220, 250 V DC	
Maximum interruption time in the auxiliary DC voltage without resetting the relay	50 ms at U_n	
Auxiliary voltage variation	38...110% of U_n (38...264 V AC)	50...120% of U_n (12...72 V DC)
	80...120% of U_n (38.4...300 V DC)	
Start-up threshold	19.2 V DC (24 V DC × 80%)	
Burden of auxiliary voltage supply under quiescent (P_q)/operating condition	DC <13.0 W (nominal)/<18.0 W (max.) AC <16.0 W (nominal)/<21.0 W (max.)	DC <13.0 W (nominal)/<18.0 W (max.)
Ripple in the DC auxiliary voltage	Max 15% of the DC value (at frequency of 100 Hz)	
Fuse type	T4A/250 V	

Table 8. Energizing inputs

Description	Value	
Rated frequency	50/60 Hz ± 5 Hz	
Current inputs	Rated current, I_n	1/5 A ¹⁾
	Thermal withstand capability:	
	• Continuously	20 A
	• For 1 s	500 A
	Dynamic current withstand:	
• Half-wave value	1250 A	
Input impedance	<20 mΩ	
Voltage inputs	Rated voltage	60...210 V AC
	Voltage withstand:	
	• Continuous	240 V AC
	• For 10 s	360 V AC
Burden at rated voltage	<0.05 VA	

1) Residual current and/or phase current

Table 9. Binary inputs

Description	Value
Operating range	±20% of the rated voltage
Rated voltage	24...250 V DC
Current drain	1.6...1.9 mA
Power consumption	31.0...570.0 mW
Threshold voltage	16...176 V DC
Reaction time	<3 ms

Table 10. RTD/mA measurement (XRGGIO130)

Description	Value		
RTD inputs	Supported RTD sensors	100 Ω platinum 250 Ω platinum 100 Ω nickel 120 Ω nickel 250 Ω nickel 10 Ω copper	TCR 0.00385 (DIN 43760) TCR 0.00385 TCR 0.00618 (DIN 43760) TCR 0.00618 TCR 0.00618 TCR 0.00427
	Supported resistance range	0...2 kΩ	
	Maximum lead resistance (three-wire measurement)	25 Ω per lead	
	Isolation	2 kV (inputs to protective earth)	
	Response time	<4 s	
	RTD/resistance sensing current	Maximum 0.33 mA rms	
	Operation accuracy	Resistance ± 2.0% or ±1 Ω	Temperature ±1°C 10 Ω copper: ±2°C
mA inputs	Supported current range	0...20 mA	
	Current input impedance	44 Ω ± 0.1%	
	Operation accuracy	±0.5% or ±0.01 mA	

Table 11. Signal output X100: SO1

Description	Value
Rated voltage	250 V AC/DC
Continuous contact carry	5 A
Make and carry for 3.0 s	15 A
Make and carry for 0.5 s	30 A
Breaking capacity when the control-circuit time constant L/R<40 ms, at 48/110/220 V DC	1 A/0.25 A/0.15 A
Minimum contact load	100 mA at 24 V AC/DC

Table 12. Signal outputs and IRF output

Description	Value
Rated voltage	250 V AC/DC
Continuous contact carry	5 A
Make and carry for 3.0 s	10 A
Make and carry 0.5 s	15 A
Breaking capacity when the control-circuit time constant $L/R < 40$ ms, at 48/110/220 V DC	1 A/0.25 A/0.15 A
Minimum contact load	10 mA at 5 V AC/DC

Table 13. Double-pole power output relays with TCS function

Description	Value
Rated voltage	250 V AC/DC
Continuous contact carry	8 A
Make and carry for 3.0 s	15 A
Make and carry for 0.5 s	30 A
Breaking capacity when the control-circuit time constant $L/R < 40$ ms, at 48/110/220 V DC (two contacts connected in series)	5 A/3 A/1 A
Minimum contact load	100 mA at 24 V AC/DC
Trip-circuit supervision (TCS):	
• Control voltage range	20...250 V AC/DC
• Current drain through the supervision circuit	~1.5 mA
• Minimum voltage over the TCS contact	20 V AC/DC (15...20 V)

Table 14. Single-pole power output relays

Description	Value
Rated voltage	250 V AC/DC
Continuous contact carry	8 A
Make and carry for 3.0 s	15 A
Make and carry for 0.5 s	30 A
Breaking capacity when the control-circuit time constant $L/R < 40$ ms, at 48/110/220 V DC	5 A/3 A/1 A
Minimum contact load	100 mA at 24 V AC/DC

Table 15. High-speed output HSO with BIO0007

Description	Value
Rated voltage	250 V AC/DC
Continuous contact carry	6 A
Make and carry for 3.0 s	15 A
Make and carry for 0.5 s	30 A
Breaking capacity when the control-circuit time constant L/R <40 ms, at 48/110/220 V DC	5 A/3 A/1 A
Operate time	<1 ms
Reset	<20 ms, resistive load

Table 16. Front port Ethernet interfaces

Ethernet interface	Protocol	Cable	Data transfer rate
Front	TCP/IP protocol	Standard Ethernet CAT 5 cable with RJ-45 connector	10 Mbits/s

Table 17. Station communication link, fiber optic

Connector	Fiber type ¹⁾	Wave length	Typical max. length ²⁾	Permitted path attenuation ³⁾
LC	MM 62.5/125 or 50/125 μ m glass fiber core	1300 nm	2 km	<8 dB
ST	MM 62.5/125 or 50/125 μ m glass fiber core	820...900 nm	1 km	<11 dB

1) (MM) multi-mode fiber, (SM) single-mode fiber

2) Maximum length depends on the cable attenuation and quality, the amount of splices and connectors in the path.

3) Maximum allowed attenuation caused by connectors and cable together

Table 18. IRIG-B

Description	Value
IRIG time code format	B004, B005 ¹⁾
Isolation	500V 1 min
Modulation	Unmodulated
Logic level	5 V TTL
Current consumption	<4 mA
Power consumption	<20 mW

1) According to the 200-04 IRIG standard

Table 19. Lens sensor and optical fiber for arc protection

Description	Value
Fiber optic cable including lens	1.5 m, 3.0 m or 5.0 m
Normal service temperature range of the lens	-40...+100°C
Maximum service temperature range of the lens, max 1 h	+140°C
Minimum permissible bending radius of the connection fiber	100 mm

Table 20. Degree of protection of flush-mounted protection relay

Description	Value
Front side	IP 54
Rear side, connection terminals	IP 20

Table 21. Environmental conditions

Description	Value
Operating temperature range	-25...+55°C (continuous)
Short-time service temperature range	-40...+85°C (<16h) ¹⁾²⁾
Relative humidity	<93%, non-condensing
Atmospheric pressure	86...106 kPa
Altitude	Up to 2000 m
Transport and storage temperature range	-40...+85°C

1) Degradation in MTBF and HMI performance outside the temperature range of -25...+55 °C

2) For relays with an LC communication interface the maximum operating temperature is +70 °C

Table 22. Electromagnetic compatibility tests

Description	Type test value	Reference
1 MHz/100 kHz burst disturbance test		IEC 61000-4-18 IEC 60255-26, class III IEEE C37.90.1-2002
<ul style="list-style-type: none"> • Common mode • Differential mode 	2.5 kV 2.5 kV	
3 MHz, 10 MHz and 30 MHz burst disturbance test		IEC 61000-4-18 IEC 60255-26, class III
<ul style="list-style-type: none"> • Common mode 	2.5 kV	
Electrostatic discharge test		IEC 61000-4-2 IEC 60255-26 IEEE C37.90.3-2001
<ul style="list-style-type: none"> • Contact discharge • Air discharge 	8 kV 15 kV	
Radio frequency interference test		IEC 61000-4-6 IEC 60255-26, class III
	10 V (rms) f = 150 kHz...80 MHz	IEC 61000-4-3 IEC 60255-26, class III
	10 V/m (rms) f = 80...2700 MHz	ENV 50204 IEC 60255-26, class III
	10 V/m f = 900 MHz	IEEE C37.90.2-2004
	20 V/m (rms) f = 80...1000 MHz	
Fast transient disturbance test		IEC 61000-4-4 IEC 60255-26 IEEE C37.90.1-2002
<ul style="list-style-type: none"> • All ports 	4 kV	
Surge immunity test		IEC 61000-4-5 IEC 60255-26
<ul style="list-style-type: none"> • Communication • Other ports 	1 kV, line-to-earth 4 kV, line-to-earth 2 kV, line-to-line	
Power frequency (50 Hz) magnetic field immunity test		IEC 61000-4-8
<ul style="list-style-type: none"> • Continuous • 1...3 s 	300 A/m 1000 A/m	
Pulse magnetic field immunity test		IEC 61000-4-9
	1000 A/m 6.4/16 µs	
Damped oscillatory magnetic field immunity test		IEC 61000-4-10
<ul style="list-style-type: none"> • 2 s • 1 MHz 	100 A/m 400 transients/s	
Voltage dips and short interruptions		IEC 61000-4-11
	30%/10 ms 60%/100 ms 60%/1000 ms >95%/5000 ms	

Table 22. Electromagnetic compatibility tests, continued

Description	Type test value	Reference
Power frequency immunity test	Binary inputs only	IEC 61000-4-16 IEC 60255-26, class A
• Common mode	300 V rms	
• Differential mode	150 V rms	
Conducted common mode disturbances	15 Hz...150 kHz Test level 3 (10/1/10 V rms)	IEC 61000-4-16
Emission tests		EN 55011, class A IEC 60255-26 CISPR 11 CISPR 12
• Conducted		
0.15...0.50 MHz	<79 dB (μV) quasi peak <66 dB (μV) average	
0.5...30 MHz	<73 dB (μV) quasi peak <60 dB (μV) average	
• Radiated		
30...230 MHz	<40 dB (μV/m) quasi peak, measured at 10 m distance	
230...1000 MHz	<47 dB (μV/m) quasi peak, measured at 10 m distance	
1...3 GHz	<76 dB (μV/m) peak <56 dB (μV/m) average, measured at 3 m distance	
3...6 GHz	<80 dB (μV/m) peak <60 dB (μV/m) average, measured at 3 m distance	

Table 23. Insulation tests

Description	Type test value	Reference
Dielectric tests	2 kV, 50 Hz, 1 min 500 V, 50 Hz, 1 min, communication	IEC 60255-27
Impulse voltage test	5 kV, 1.2/50 μs, 0.5 J 1 kV, 1.2/50 μs, 0.5 J, communication	IEC 60255-27
Insulation resistance measurements	>100 MΩ, 500 V DC	IEC 60255-27
Protective bonding resistance	<0.1 Ω, 4 A, 60 s	IEC 60255-27

Table 24. Mechanical tests

Description	Requirement	Reference
Vibration tests (sinusoidal)	Class 2	IEC 60068-2-6 (test Fc) IEC 60255-21-1
Shock and bump test	Class 2	IEC 60068-2-27 (test Ea shock) IEC 60068-2-29 (test Eb bump) IEC 60255-21-2
Seismic test	Class 2	IEC 60255-21-3

Table 25. Environmental tests

Description	Type test value	Reference
Dry heat test	<ul style="list-style-type: none"> • 96 h at +55°C • 16 h at +85°C¹⁾ 	IEC 60068-2-2
Dry cold test	<ul style="list-style-type: none"> • 96 h at -25°C • 16 h at -40°C 	IEC 60068-2-1
Damp heat test	<ul style="list-style-type: none"> • 6 cycles (12 h + 12 h) at +25°C...+55°C, humidity >93% 	IEC 60068-2-30
Change of temperature test	<ul style="list-style-type: none"> • 5 cycles (3 h + 3 h) at -25°C...+55°C 	IEC60068-2-14
Storage test	<ul style="list-style-type: none"> • 96 h at -40°C • 96 h at +85°C 	IEC 60068-2-1 IEC 60068-2-2

1) For relays with an LC communication interface the maximum operating temperature is +70°C

Table 26. Product safety

Description	Reference
LV directive	2006/95/EC
Standard	EN 60255-27 (2013) EN 60255-1 (2009)

Table 27. EMC compliance

Description	Reference
EMC directive	2004/108/EC
Standard	EN 60255-26 (2013)

Table 28. RoHS compliance

Description
Complies with RoHS directive 2002/95/EC

Protection functions

Table 29. Three-phase non-directional overcurrent protection (PHxPTOC)

Characteristic	Value			
Operation accuracy	PHLPTOC	Depending on the frequency of the measured current: $f_n \pm 2$ Hz $\pm 1.5\%$ of the set value or $\pm 0.002 \times I_n$		
	PHHPTOC and PHIPTOC	$\pm 1.5\%$ of set value or $\pm 0.002 \times I_n$ (at currents in the range of $0.1 \dots 10 \times I_n$) $\pm 5.0\%$ of the set value (at currents in the range of $10 \dots 40 \times I_n$)		
Start time ¹⁾²⁾	PHIPTOC: $I_{\text{Fault}} = 2 \times \text{set Start value}$ $I_{\text{Fault}} = 10 \times \text{set Start value}$	Minimum	Typical	Maximum
		16 ms	19 ms	23 ms
	PHHPTOC and PHLPTOC: $I_{\text{Fault}} = 2 \times \text{set Start value}$	11 ms	12 ms	14 ms
Reset time	Typically 40 ms			
Reset ratio	Typically 0.96			
Retardation time	<30 ms			
Operate time accuracy in definite time mode	$\pm 1.0\%$ of the set value or ± 20 ms			
Operate time accuracy in inverse time mode	$\pm 5.0\%$ of the theoretical value or ± 20 ms ³⁾			
Suppression of harmonics	RMS: No suppression DFT: -50 dB at $f = n \times f_n$, where $n = 2, 3, 4, 5, \dots$ Peak-to-Peak: No suppression P-to-P+backup: No suppression			

1) Set *Operate delay time* = 0,02 s, *Operate curve type* = IEC definite time, *Measurement mode* = default (depends on stage), current before fault = $0.0 \times I_n$, $f_n = 50$ Hz, fault current in one phase with nominal frequency injected from random phase angle, results based on statistical distribution of 1000 measurements

2) Includes the delay of the signal output contact

3) Includes the delay of the heavy-duty output contact

Table 30. Three-phase non-directional overcurrent protection (PHxPTOC) main settings

Parameter	Function	Value (Range)	Step
Start value	PHLPTOC	$0.05 \dots 5.00 \times I_n$	0.01
	PHHPTOC	$0.10 \dots 40.00 \times I_n$	0.01
	PHIPTOC	$1.00 \dots 40.00 \times I_n$	0.01
Time multiplier	PHLPTOC and PHHPTOC	0.05...15.00	0.01
Operate delay time	PHLPTOC and PHHPTOC	40...200000 ms	10
	PHIPTOC	20...200000 ms	10
Operating curve type ¹⁾	PHLPTOC	Definite or inverse time Curve type: 1, 2, 3, 4, 5, 6, 7, 8, 9, 10, 11, 12, 13, 14, 15, 17, 18, 19	
	PHHPTOC	Definite or inverse time Curve type: 1, 3, 5, 9, 10, 12, 15, 17	
	PHIPTOC	Definite time	

1) For further reference, see the Operation characteristics table

Table 31. Residual overvoltage protection (ROVPTOV)

Characteristic	Value		
Operation accuracy	Depending on the frequency of the measured voltage: $f_n \pm 2$ Hz $\pm 1.5\%$ of the set value or $\pm 0.002 \times U_n$		
Start time ¹⁾²⁾	Minimum	Typical	Maximum
	48 ms	51 ms	54 ms
Reset time	Typically 40 ms		
Reset ratio	Typically 0.96		
Retardation time	<35 ms		
Operate time accuracy in definite time mode	$\pm 1.0\%$ of the set value or ± 20 ms		
Suppression of harmonics	DFT: -50 dB at $f = n \times f_n$, where $n = 2, 3, 4, 5, \dots$		

1) Residual voltage before fault = $0.0 \times U_n$, $f_n = 50$ Hz, residual voltage with nominal frequency injected from random phase angle, results based on statistical distribution of 1000 measurements

2) Includes the delay of the signal output contact

Table 32. Residual overvoltage protection (ROVPTOV) main settings

Parameter	Function	Value (Range)	Step
Start value	ROVPTOV	$0.010 \dots 1.000 \times U_n$	0.001
Operate delay time	ROVPTOV	40...300000 ms	1

Table 33. Three-phase undervoltage protection (PHPTUV)

Characteristic	Value		
Operation accuracy	Depending on the frequency of the voltage measured: $f_n \pm 2$ Hz $\pm 1.5\%$ of the set value or $\pm 0.002 \times U_n$		
Start time ¹⁾²⁾	Minimum	Typical	Maximum
	62 ms	66 ms	70 ms
Reset time	Typically 40 ms		
Reset ratio	Depends on the set <i>Relative hysteresis</i>		
Retardation time	<35 ms		
Operate time accuracy in definite time mode	$\pm 1.0\%$ of the set value or ± 20 ms		
Operate time accuracy in inverse time mode	$\pm 5.0\%$ of the theoretical value or ± 20 ms ³⁾		
Suppression of harmonics	DFT: -50 dB at $f = n \times f_n$, where $n = 2, 3, 4, 5, \dots$		

1) *Start value* = $1.0 \times U_n$, Voltage before fault = $1.1 \times U_n$, $f_n = 50$ Hz, undervoltage in one phase-to-phase with nominal frequency injected from random phase angle, results based on statistical distribution of 1000 measurements

2) Includes the delay of the signal output contact

3) Minimum *Start value* = 0.50, *Start value* multiples in range of 0.90...0.20

Table 34. Three-phase undervoltage protection (PHPTUV) main settings

Parameter	Function	Value (Range)	Step
Start value	PHPTUV	$0.05...1.20 \times U_n$	0.01
Time multiplier	PHPTUV	0.05...15.00	0.01
Operate delay time	PHPTUV	60...300000 ms	10
Operating curve type ¹⁾	PHPTUV	Definite or inverse time Curve type: 5, 15, 21, 22, 23	

1) For further reference, see the Operation characteristics table

Table 35. Three-phase overvoltage protection (PHPTOV)

Characteristic	Value		
Operation accuracy	Depending on the frequency of the measured voltage: $f_n \pm 2$ Hz $\pm 1.5\%$ of the set value or $\pm 0.002 \times U_n$		
Start time ¹⁾²⁾	$U_{Fault} = 1.1 \times \text{set Start value}$	Minimum 23 ms	Typical 27 ms
			Maximum 31 ms
Reset time	Typically 40 ms		
Reset ratio	Depends on the set <i>Relative hysteresis</i>		
Retardation time	<35 ms		
Operate time accuracy in definite time mode	$\pm 1.0\%$ of the set value or ± 20 ms		
Operate time accuracy in inverse time mode	$\pm 5.0\%$ of the theoretical value or ± 20 ms ³⁾		
Suppression of harmonics	DFT: -50 dB at $f = n \times f_n$, where $n = 2, 3, 4, 5, \dots$		

1) $Start\ value = 1.0 \times U_n$, Voltage before fault = $0.9 \times U_n$, $f_n = 50$ Hz, overvoltage in one phase-to-phase with nominal frequency injected from random phase angle, results based on statistical distribution of 1000 measurements

2) Includes the delay of the signal output contact

3) Maximum $Start\ value = 1.20 \times U_n$, $Start\ value$ multiples in range of 1.10...2.00

Table 36. Three-phase overvoltage protection (PHPTOV) main settings

Parameter	Function	Value (Range)	Step
Start value	PHPTOV	$0.05...1.60 \times U_n$	0.01
Time multiplier	PHPTOV	0.05...15.00	0.01
Operate delay time	PHPTOV	40...300000 ms	10
Operating curve type ¹⁾	PHPTOV	Definite or inverse time Curve type: 5, 15, 17, 18, 19, 20	

1) For further reference, see the Operation characteristics table

Table 37. Positive-sequence undervoltage protection (PSPTUV)

Characteristic	Value		
Operation accuracy	Depending on the frequency of the measured voltage: $f_n \pm 2$ Hz $\pm 1.5\%$ of the set value or $\pm 0.002 \times U_n$		
Start time ¹⁾²⁾	Minimum	Typical	Maximum
	$U_{Fault} = 0.99 \times \text{set Start value}$ $U_{Fault} = 0.9 \times \text{set Start value}$	52 ms 44 ms	55 ms 47 ms
Reset time	Typically 40 ms		
Reset ratio	Depends on the set <i>Relative hysteresis</i>		
Retardation time	<35 ms		
Operate time accuracy in definite time mode	$\pm 1.0\%$ of the set value or ± 20 ms		
Suppression of harmonics	DFT: -50 dB at $f = n \times f_n$, where $n = 2, 3, 4, 5, \dots$		

1) *Start value* = $1.0 \times U_n$, positive-sequence voltage before fault = $1.1 \times U_n$, $f_n = 50$ Hz, positive sequence undervoltage with nominal frequency injected from random phase angle, results based on statistical distribution of 1000 measurements

2) Includes the delay of the signal output contact

Table 38. Positive-sequence undervoltage protection (PSPTUV) main settings

Parameter	Function	Value (Range)	Step
Start value	PSPTUV	$0.010 \dots 1.200 \times U_n$	0.001
Operate delay time	PSPTUV	40...120000 ms	10
Voltage block value	PSPTUV	$0.01 \dots 1.00 \times U_n$	0.01

Table 39. Negative-sequence overvoltage protection (NSPTOV)

Characteristic	Value		
Operation accuracy	Depending on the frequency of the voltage measured: f_n $\pm 1.5\%$ of the set value or $\pm 0.002 \times U_n$		
Start time ¹⁾²⁾	Minimum	Typical	Maximum
	$U_{Fault} = 1.1 \times \text{set Start value}$ $U_{Fault} = 2.0 \times \text{set Start value}$	33 ms 24 ms	35 ms 26 ms
Reset time	Typically 40 ms		
Reset ratio	Typically 0.96		
Retardation time	<35 ms		
Operate time accuracy in definite time mode	$\pm 1.0\%$ of the set value or ± 20 ms		
Suppression of harmonics	DFT: -50 dB at $f = n \times f_n$, where $n = 2, 3, 4, 5, \dots$		

1) Negative-sequence voltage before fault = $0.0 \times U_n$, $f_n = 50$ Hz, negative-sequence overvoltage with nominal frequency injected from random phase angle, results based on statistical distribution of 1000 measurements

2) Includes the delay of the signal output contact

Table 40. Negative-sequence overvoltage protection (NSPTOV) main settings

Parameter	Function	Value (Range)	Step
Start value	NSPTOV	$0.010 \dots 1.000 \times U_n$	0.001
Operate delay time	NSPTOV	40...120000 ms	1

Table 41. Frequency protection (FRPFRQ)

Characteristic		Value
Operation accuracy	f>/f<	±5 mHz
	df/dt	±50 mHz/s (in range df/dt <5 Hz/s) ±2.0% of the set value (in range 5 Hz/s < df/dt < 15 Hz/s)
Start time	f>/f<	<80 ms
	df/dt	<120 ms
Reset time		<150 ms
Operate time accuracy		±1.0% of the set value or ±30 ms

Table 42. Frequency protection (FRPFRQ) main settings

Parameter	Function	Value (Range)	Step
Operation mode	FRPFRQ	1 = Freq< 2 = Freq> 3 = df/dt 4 = Freq< + df/dt 5 = Freq> + df/dt 6 = Freq< OR df/dt 7 = Freq> OR df/dt	-
Start value Freq>	FRPFRQ	0.9000...1.2000 × f _n	0.0001
Start value Freq<	FRPFRQ	0.8000...1.1000 × f _n	0.0001
Start value df/dt	FRPFRQ	-0.2000...0.2000 × f _n /s	0.005
Operate Tm Freq	FRPFRQ	80...200000 ms	10
Operate Tm df/dt	FRPFRQ	120...200000 ms	10

Table 43. Three-phase thermal overload protection, two time constants (T2PTTR)

Characteristic	Value
Operation accuracy	Depending on the frequency of the measured current: f _n ±2 Hz Current measurement: ±1.5% of the set value or ±0.002 × I _n (at currents in the range of 0.01...4.00 × I _n)
Operate time accuracy ¹⁾	±2.0% of the theoretical value or ±0.50 s

1) Overload current > 1.2 × Operate level temperature

Table 44. Three-phase thermal overload protection, two time constants (T2PTTR) main settings

Parameter	Function	Value (Range)	Step
Temperature rise	T2PTTR	0.0...200.0°C	0.1
Max temperature	T2PTTR	0.0...200.0°C	0.1
Operate temperature	T2PTTR	80.0...120.0%	0.1
Short time constant	T2PTTR	6...60000 s	1
Weighting factor p	T2PTTR	0.00...1.00	0.01
Current reference	T2PTTR	0.05...4.00 × I _n	0.01
Operation	T2PTTR	1 = on 5 = off	-

Table 45. Arc protection (ARCSARC)

Characteristic		Value		
Operation accuracy		$\pm 3\%$ of the set value or $\pm 0.01 \times I_n$		
Operate time	<i>Operation mode</i> = "Light only"	Minimum	Typical	Maximum
		9 ms	10 ms	12 ms
	4 ms	6 ms	7 ms	
Reset time		Typically 40 ms		
Reset ratio		Typically 0.96		

Table 46. Arc protection (ARCSARC) main settings

Parameter	Function	Value (Range)	Step
Phase start value	ARCSARC	$0.50 \dots 40.00 \times I_n$	0.01
Ground start value	ARCSARC	$0.05 \dots 8.00 \times I_n$	0.01
Operation mode	ARCSARC	2 = Light only 3 = BI controlled	-

Table 47. Multipurpose protection (MAPGAPC)

Characteristic	Value
Operation accuracy	$\pm 1.0\%$ of the set value or ± 20 ms

Table 48. Multipurpose protection (MAPGAPC) main settings

Parameter	Function	Value (Range)	Step
Start value	MAPGAPC	-10000.0...10000.0	0.1
Operate delay time	MAPGAPC	0...200000 ms	100
Operation mode	MAPGAPC	1 = Over 2 = Under	-

Table 49. Load-shedding and restoration (LSHDPFRQ)

Characteristic		Value
Operation accuracy	f<	± 5 mHz
	df/dt	± 100 mHz/s (in range $ df/dt < 5$ Hz/s) $\pm 2.0\%$ of the set value (in range $5 \text{ Hz/s} < df/dt < 15 \text{ Hz/s}$)
Start time	f<	<80 ms
	df/dt	<120 ms
Reset time	<150 ms	
Operate time accuracy	$\pm 1.0\%$ of the set value or ± 30 ms	

Table 50. Load-shedding and restoration (LSHDPRQ) main settings

Parameter	Function	Value (Range)	Step
Load shed mode	LSHDPRQ	1 = Freq< 6 = Freq< OR df/dt 8 = Freq< AND df/dt	-
Restore mode	LSHDPRQ	1 = Disabled 2 = Auto 3 = Manual	-
Start value Freq	LSHDPRQ	0.800...1.200 × f _n	0.001
Start value df/dt	LSHDPRQ	-0.200...-0.005 × f _n /s	0.005
Operate Tm Freq	LSHDPRQ	80...200000 ms	10
Operate Tm df/dt	LSHDPRQ	120...200000 ms	10
Restore start Val	LSHDPRQ	0.800...1.200 × f _n	0.001
Restore delay time	LSHDPRQ	80...200000 ms	10

Table 51. Operation characteristics

Parameter	Value (Range)
Operating curve type	1 = ANSI Ext. inv. 2 = ANSI Very. inv. 3 = ANSI Norm. inv. 4 = ANSI Mod inv. 5 = ANSI Def. Time 6 = L.T.E. inv. 7 = L.T.V. inv. 8 = L.T. inv. 9 = IEC Norm. inv. 10 = IEC Very inv. 11 = IEC inv. 12 = IEC Ext. inv. 13 = IEC S.T. inv. 14 = IEC L.T. inv. 15 = IEC Def. Time 17 = Programmable 18 = RI type 19 = RD type
Operating curve type (voltage protection)	5 = ANSI Def. Time 15 = IEC Def. Time 17 = Inv. Curve A 18 = Inv. Curve B 19 = Inv. Curve C 20 = Programmable 21 = Inv. Curve A 22 = Inv. Curve B 23 = Programmable

Control functions

Table 52. Tap changer position indication (TPOSYLTC)

Description	Value
Response time for binary inputs	Typically 100 ms

Table 53. Tap changer control with voltage regulator (OLATCC)

Characteristic	Value
Operation accuracy ¹⁾	Depending on the frequency of the measured current: $f_n \pm 2$ Hz Differential voltage $U_d = \pm 0.5\%$ of the measured value or $\pm 0.005 \times U_n$ (in measured voltages $< 2.0 \times U_n$) Operation value = $\pm 1.5\%$ of the U_d for $U_s = 1.0 \times U_n$
Operate time accuracy in definite time mode ²⁾	+4.0%/-0% of the set value
Operate time accuracy in inverse time mode ²⁾	+8.5%/-0% of the set value (at theoretical B in range of 1.1...5.0) Also note fixed minimum operate time (IDMT) 1 s.
Reset ratio for control operation	Typically 0.80 (1.20)
Reset ratio for analogue based blockings (except run back raise voltage blocking)	Typically 0.96 (1.04)

1) Default setting values used

2) Voltage before deviation = set *Band center voltage*

Table 54. Tap changer control with voltage regulator (OLATCC) main settings

Parameter	Function	Value (Range)	Step
Auto parallel mode	OLATCC	2 = Auto master 3 = Auto follower 5 = NRP 7 = MCC	-
Band center voltage	OLATCC	0.000...2.000 × U _n	0.001
Line drop V Ris	OLATCC	0.0...25.0%	0.1
Line drop V React	OLATCC	0.0...25.0%	0.1
Stability factor	OLATCC	0.0...70.0%	0.1
Load phase angle	OLATCC	-89...89°	1
Control delay time 1	OLATCC	1000...300000 ms	100
Control delay time 2	OLATCC	1000...300000 ms	100
Operation mode	OLATCC	1 = Manual 2 = Auto single 3 = Auto parallel 4 = Input control 5 = Command	-
Custom Man blocking	OLATCC	1 = Custom disabled 2 = OC 3 = UV 4 = OC, UV 5 = EXT 6 = OC, EXT 7 = UV, EXT 8 = OC, UV, EXT	-
Delay characteristics	OLATCC	0 = Inverse time 1 = Definite time	-
Band width voltage	OLATCC	1.20...18.00 %U _n	0.01
Load current limit	OLATCC	0.10...5.00 × I _n	0.01
Block lower voltage	OLATCC	0.10...1.20 × U _n	0.01
Runback raise V	OLATCC	0.80...2.40 × U _n	0.01
Cir current limit	OLATCC	0.10...5.00 × I _n	0.01
LDC limit	OLATCC	0.00...2.00 × U _n	0.01
Lower block tap	OLATCC	-36...36	-
Raise block tap	OLATCC	-36...36	-
LCT pulse time	OLATCC	500...10000 ms	100
LDC enable	OLATCC	0 = False 1 = True	-
Follower delay time	OLATTC	6...20 s	-

Table 55. Synchronism and energizing check (SECRSYN)

Characteristic	Value
Operation accuracy	Depending on the frequency of the voltage measured: $f_n \pm 1$ Hz Voltage: $\pm 3.0\%$ of the set value or $\pm 0.01 \times U_n$ Frequency: ± 10 mHz Phase angle: $\pm 3^\circ$
Reset time	<50 ms
Reset ratio	Typically 0.96
Operate time accuracy in definite time mode	$\pm 1.0\%$ of the set value or ± 20 ms

Table 56. Synchronism and energizing check (SECRSYN) main settings

Parameter	Function	Value (Range)	Step
Live dead mode	SECRSYN	-1 = Off 1 = Both Dead 2 = Live L, Dead B 3 = Dead L, Live B 4 = Dead Bus, L Any 5 = Dead L, Bus Any 6 = One Live, Dead 7 = Not Both Live	-
Difference voltage	SECRSYN	$0.01 \dots 0.50 \times U_n$	0.01
Difference frequency	SECRSYN	$0.001 \dots 0.100 \times f_n$	0.001
Difference angle	SECRSYN	$5 \dots 90^\circ$	1
Synchrocheck mode	SECRSYN	1 = Off 2 = Synchronous 3 = Asynchronous	-
Dead line value	SECRSYN	$0.1 \dots 0.8 \times U_n$	0.1
Live line value	SECRSYN	$0.2 \dots 1.0 \times U_n$	0.1
Max energizing V	SECRSYN	$0.50 \dots 1.15 \times U_n$	0.01
Control mode	SECRSYN	1 = Continuous 2 = Command	-
Close pulse	SECRSYN	200...60000 ms	10
Phase shift	SECRSYN	$-180 \dots 180^\circ$	1
Minimum Syn time	SECRSYN	0...60000 ms	10
Maximum Syn time	SECRSYN	100...6000000 ms	10
Energizing time	SECRSYN	100...60000 ms	10
Closing time of CB	SECRSYN	40...250 ms	10

Condition and supervision functions

Table 57. Current circuit supervision (CCSPVC)

Characteristic	Value
Operate time ¹⁾	<30 ms

1) Including the delay of the output contact

Table 58. Current circuit supervision (CCSPVC) main settings

Parameter	Function	Value (Range)	Step
Start value	CCSPVC	$0.05...0.20 \times I_n$	0.01
Max operate current	CCSPVC	$1.00...5.00 \times I_n$	0.01

Table 59. Fuse failure supervision (SEQSPVC)

Characteristic	Function	Value	Value
Operate time ¹⁾	NPS function	$U_{Fault} = 1.1 \times \text{set } Neg \text{ Seq voltage } Lev$	<33 ms
		$U_{Fault} = 5.0 \times \text{set } Neg \text{ Seq voltage } Lev$	<18 ms
	Delta function	$\Delta U = 1.1 \times \text{set } Voltage \text{ change rate}$	<30 ms
		$\Delta U = 2.0 \times \text{set } Voltage \text{ change rate}$	<24 ms

1) Includes the delay of the signal output contact, $f_n = 50$ Hz, fault voltage with nominal frequency injected from random phase angle, results based on statistical distribution of 1000 measurements

Table 60. Runtime counter for machines and devices (MDSOPT)

Description	Value
Motor runtime measurement accuracy ¹⁾	$\pm 0.5\%$

1) Of the reading, for a stand-alone relay, without time synchronization

Measurement functions

Table 61. Three-phase current measurement (CMMXU)

Characteristic	Value
Operation accuracy	Depending on the frequency of the measured current: $f_n \pm 2$ Hz $\pm 0.5\%$ or $\pm 0.002 \times I_n$ (at currents in the range of $0.01 \dots 4.00 \times I_n$)
Suppression of harmonics	DFT: -50 dB at $f = n \times f_n$, where $n = 2, 3, 4, 5, \dots$ RMS: No suppression

Table 62. Sequence current measurement (CSMSQI)

Characteristic	Value
Operation accuracy	Depending on the frequency of the measured current: $f/f_n = \pm 2$ Hz $\pm 1.0\%$ or $\pm 0.002 \times I_n$ at currents in the range of $0.01 \dots 4.00 \times I_n$
Suppression of harmonics	DFT: -50 dB at $f = n \times f_n$, where $n = 2, 3, 4, 5, \dots$

Table 63. Three-phase voltage measurement (VMMXU)

Characteristic	Value
Operation accuracy	Depending on the frequency of the voltage measured: $f_n \pm 2$ Hz At voltages in range $0.01 \dots 1.15 \times U_n$ $\pm 0.5\%$ or $\pm 0.002 \times U_n$
Suppression of harmonics	DFT: -50 dB at $f = n \times f_n$, where $n = 2, 3, 4, 5, \dots$ RMS: No suppression

Table 64. Residual voltage measurement (RESVMMXU)

Characteristic	Value
Operation accuracy	Depending on the frequency of the measured voltage: $f/f_n = \pm 2$ Hz $\pm 0.5\%$ or $\pm 0.002 \times U_n$
Suppression of harmonics	DFT: -50 dB at $f = n \times f_n$, where $n = 2, 3, 4, 5, \dots$ RMS: No suppression

Table 65. Sequence voltage measurement (VSMSQI)

Characteristic	Value
Operation accuracy	Depending on the frequency of the voltage measured: $f_n \pm 2$ Hz At voltages in range $0.01 \dots 1.15 \times U_n$ $\pm 1.0\%$ or $\pm 0.002 \times U_n$
Suppression of harmonics	DFT: -50 dB at $f = n \times f_n$, where $n = 2, 3, 4, 5, \dots$

Table 66. Three-phase power and energy measurement (PEMMXU)

Characteristic	Value
Operation accuracy	At all three currents in range $0.10 \dots 1.20 \times I_n$ At all three voltages in range $0.50 \dots 1.15 \times U_n$ At the frequency $f_n \pm 1$ Hz $\pm 1.5\%$ for apparent power S $\pm 1.5\%$ for active power P and active energy ¹⁾ $\pm 1.5\%$ for reactive power Q and reactive energy ²⁾ ± 0.015 for power factor
Suppression of harmonics	DFT: -50 dB at $f = n \times f_n$, where $n = 2, 3, 4, 5, \dots$

1) $|\text{PF}| > 0.5$ which equals $|\cos\phi| > 0.5$ 2) $|\text{PF}| < 0.86$ which equals $|\sin\phi| > 0.5$

Table 67. RTD/mA measurement (XRGGIO130)

Description	Value		
RTD inputs	Supported RTD sensors	100 Ω platinum 250 Ω platinum 100 Ω nickel 120 Ω nickel 250 Ω nickel 10 Ω copper	TCR 0.00385 (DIN 43760) TCR 0.00385 TCR 0.00618 (DIN 43760) TCR 0.00618 TCR 0.00618 TCR 0.00427
	Supported resistance range	0...2 k Ω	
	Maximum lead resistance (three-wire measurement)	25 Ω per lead	
	Isolation	2 kV (inputs to protective earth)	
	Response time	<4 s	
	RTD/resistance sensing current	Maximum 0.33 mA rms	
	Operation accuracy	Resistance $\pm 2.0\%$ or $\pm 1 \Omega$	Temperature $\pm 1^\circ\text{C}$ 10 Ω copper: $\pm 2^\circ\text{C}$
mA inputs	Supported current range	0...20 mA	
	Current input impedance	44 $\Omega \pm 0.1\%$	
	Operation accuracy	$\pm 0.5\%$ or ± 0.01 mA	

Table 68. Frequency measurement (FMMXU)

Characteristic	Value
Operation accuracy	± 5 mHz (in measurement range 35...75 Hz)

Other functions

Table 69. Pulse timer (PTGAPC)

Characteristic	Value
Operate time accuracy	$\pm 1.0\%$ of the set value or ± 20 ms

Table 70. Time delay off (8 pcs) (TOFPAGC)

Characteristic	Value
Operate time accuracy	$\pm 1.0\%$ of the set value or ± 20 ms

Table 71. Time delay on (8 pcs) (TONGAPC)

Characteristic	Value
Operate time accuracy	$\pm 1.0\%$ of the set value or ± 20 ms

20. Local HMI

The relay is available with two optional displays, a large one and a small one. The large display is suited for relay installations where the front panel user interface is frequently used and a single line diagram is required. The small display is suited for remotely controlled substations where the relay is only occasionally accessed locally via the front panel user interface.

Both LCD displays offer front-panel user interface functionality with menu navigation and menu views. However, the large display offers increased front-panel usability with less menu scrolling and improved information overview. In addition, the large display includes a user-configurable single line diagram (SLD) with position indication for the associated primary equipment. Depending on the chosen standard configuration, the relay displays the related measuring values, apart from the

default single line diagram. The SLD view can also be accessed using the Web browser-based user interface. The default SLD can be modified according to user requirements by using the Graphical Display Editor in PCM600. The user can create up to 10 SLD pages.

The local HMI includes a push button (L/R) for local/remote operation of the relay. When the relay is in the local mode, it can be operated only by using the local front panel user interface. When the relay is in the remote mode, it can execute commands sent from a remote location. The relay supports the remote selection of local/remote mode via a binary input. This feature facilitates, for example, the use of an external switch at the substation to ensure that all relays are in the local mode during maintenance work and that the circuit breakers cannot be operated remotely from the network control center.

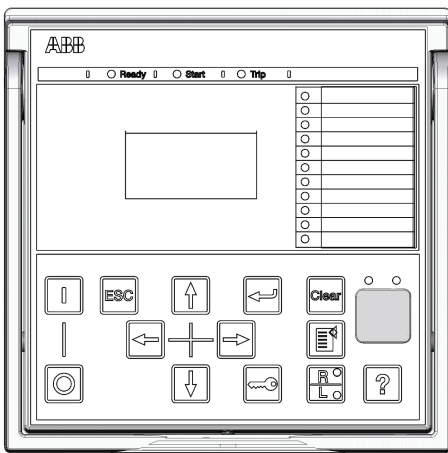

Figure 10. Small display

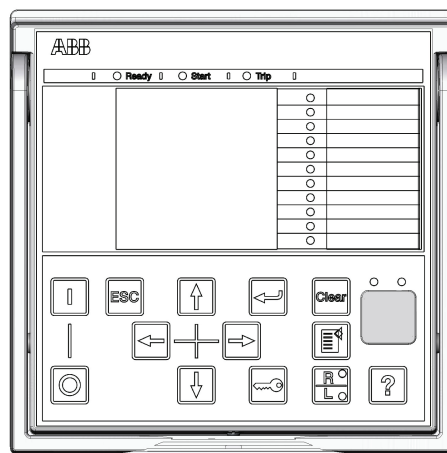

Figure 11. Large display

Table 72. Small display

Character size ¹⁾	Rows in the view	Characters per row
Small, mono-spaced (6 × 12 pixels)	5	20
Large, variable width (13 × 14 pixels)	3	8 or more

1) Depending on the selected language

Table 73. Large display

Character size ¹⁾	Rows in the view	Characters per row
Small, mono-spaced (6 × 12 pixels)	10	20
Large, variable width (13 × 14 pixels)	7	8 or more

1) Depending on the selected language

21. Mounting methods

By means of appropriate mounting accessories, the standard relay case can be flush mounted, semi-flush mounted or wall mounted. The flush mounted and wall mounted relay cases can also be mounted in a tilted position (25°) using special accessories.

Further, the relays can be mounted in any standard 19" instrument cabinet by means of 19" mounting panels available with cut-outs for one or two relays. Alternatively, the relays can be mounted in 19" instrument cabinets by means of 4U Combiflex equipment frames.

For routine testing purposes, the relay cases can be equipped with test switches, type RTXP 18, which can be mounted side by side with the relay cases.

Mounting methods

- Flush mounting
- Semi-flush mounting
- Semi-flush mounting in a 25° tilt
- Rack mounting
- Wall mounting
- Mounting to a 19" equipment frame
- Mounting with an RTXP 18 test switch to a 19" rack

Panel cut-out for flush mounting

- Height: 161.5 ±1 mm
- Width: 165.5 ±1 mm

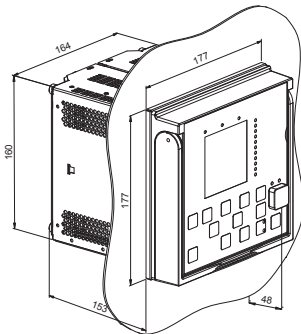

Figure 12. Flush mounting

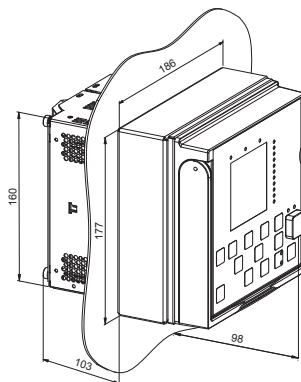

Figure 13. Semi-flush mounting

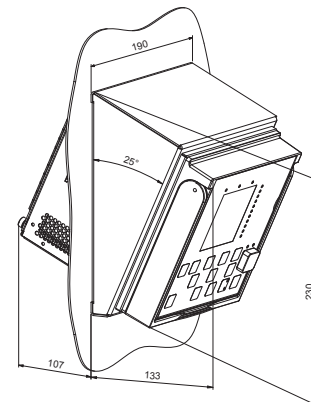

Figure 14. Semi-flush mounting in a 25° tilt

22. Relay case and plug-in unit

The relay cases are assigned to a certain type of plug-in unit. For safety reasons, the relay cases for current measuring relays are provided with automatically operating contacts for short-circuiting the CT secondary circuits when a relay unit is withdrawn from its case. The relay case is further provided with a mechanical coding system preventing the current measuring relay units from being inserted into relay cases intended for voltage measuring relay units.

23. Selection and ordering data

Use [ABB Library](#) to access the selection and ordering information and to generate the order number.

[Product Selection Tool](#) (PST), a Next-Generation Order Number Tool, supports order code creation for ABB Distribution Automation IEC products with emphasis on, but not exclusively for, the Relion product family. PST is an easy-to-use, online tool always containing the latest product information. The complete order code can be created with detailed specification and the result can be printed and mailed. Registration is required.

24. Accessories and ordering data

Table 74. Cables

Item	Order number
Optical sensor for arc protection, cable length 1.5 m	1MRS120534-1.5
Optical sensor for arc protection, cable length 3.0 m	1MRS120534-3
Optical sensor for arc protection, cable length 5.0 m	1MRS120534-5
Optical sensor for arc protection, cable length 7.0 m	1MRS120534-7
Optical sensor for arc protection, cable length 10.0 m	1MRS120534-10
Optical sensor for arc protection, cable length 15.0 m	1MRS120534-15
Optical sensor for arc protection, cable length 20.0 m	1MRS120534-20
Optical sensor for arc protection, cable length 25.0 m	1MRS120534-25
Optical sensor for arc protection, cable length 30.0 m	1MRS120534-30

Table 75. Mounting accessories

Item	Order number
Semi-flush mounting kit	1MRS050696
Wall mounting kit	1MRS050697
Inclined semi-flush mounting kit	1MRS050831
19" rack mounting kit with cut-out for one relay	1MRS050694
19" rack mounting kit with cut-out for two relays	1MRS050695
Mounting bracket for one relay with test switch RTXP in 4U Combiflex (RHGT 19" variant C)	2RCA022642P0001
Mounting bracket for one relay in 4U Combiflex (RHGT 19" variant C)	2RCA022643P0001
19" rack mounting kit for one relay and one RTXP18 test switch (the test switch is not included in the delivery)	2RCA021952A0003
19" rack mounting kit for one relay and one RTXP24 test switch (the test switch is not included in the delivery)	2RCA022561A0003
Functional earthing flange for RTD modules ¹⁾	2RCA036978A0001
Replacement kit for a Strömberg SP_J40 series relay (cut-out in the center of the installation plate)	2RCA027871A0001
Replacement kit for a Strömberg SP_J40 series relay (cut-out on the left or the right of the installation plate)	2RCA027874A0001
Replacement kit for two Strömberg SP_J3 series relays	2RCA027880A0001
19" rack replacement kit for Strömberg SP_J3/J6 series relays (one cut-out)	2RCA027894A0001
19" rack replacement kit for Strömberg SP_J3/J6 series relays (two cut-outs)	2RCA027897A0001
Replacement kit for a Strömberg SP_J6 series relay	2RCA027881A0001
Replacement kit for three BBC S_ series relays	2RCA027882A0001
Replacement kit for a SPA 300 series relay	2RCA027885A0001

1) Cannot be used when the protection relay is mounted with the Combiflex 19" equipment frame (2RCA032826A0001)

25. Tools

The protection relay is delivered as a preconfigured unit. The default parameter setting values can be changed from the front-panel user interface (local HMI), the Web browser-based user interface (Web HMI) or Protection and Control IED Manager PCM600 in combination with the relay-specific connectivity package.

PCM600 offers extensive relay configuration functions. For example, depending on the protection relay, the relay signals, application, graphical display and single-line diagram, and IEC 61850 communication, including horizontal GOOSE communication, can be modified with PCM600.

When the Web HMI is used, the protection relay can be accessed either locally or remotely using a Web browser

(Internet Explorer). For security reasons, the Web HMI is disabled by default but it can be enabled via the local HMI. The Web HMI functionality can be limited to read-only access.

The relay connectivity package is a collection of software and specific relay information, which enables system products and tools to connect and interact with the protection relay. The connectivity packages reduce the risk of errors in system integration, minimizing device configuration and setup times. Further, the connectivity packages for protection relays of this product series include a flexible update tool for adding one additional local HMI language to the protection relay. The update tool is activated using PCM600, and it enables multiple updates of the additional HMI language, thus offering flexible means for possible future language updates.

Table 76. Tools

Description	Version
PCM600	2.6 (Rollup 20150626) or later
Web browser	IE 8.0, IE 9.0, IE 10.0 or IE 11.0
REU615 Connectivity Package	5.1 or later

Table 77. Supported functions

Function	Web HMI	PCM600
Relay parameter setting	•	•
Saving of relay parameter settings in the relay	•	•
Signal monitoring	•	•
Disturbance recorder handling	•	•
Alarm LED viewing	•	•
Access control management	•	•
Relay signal configuration (Signal Matrix)	-	•
Modbus® communication configuration (communication management)	-	•
DNP3 communication configuration (communication management)	-	•
IEC 60870-5-103 communication configuration (communication management)	-	•
Saving of relay parameter settings in the tool	-	•
Disturbance record analysis	-	•
XRIO parameter export/import	•	•
Graphical display configuration	-	•
Application configuration	-	•
IEC 61850 communication configuration, GOOSE (communication configuration)	-	•
Phasor diagram viewing	•	-
Event viewing	•	•
Saving of event data on the user's PC	•	•
Online monitoring	-	•

• = Supported

26. Cyber security

The relay supports role based user authentication and authorization. It can store 2048 audit trail events to a non-volatile memory. The non-volatile memory is based on a memory type which does not need battery backup or regular component exchange to maintain the memory storage. FTP

and Web HMI use TLS encryption with a minimum of 128 bit key length protecting the data in transit. In this case the used communication protocols are FTPS and HTTPS. All rear communication ports and optional protocol services can be deactivated according to the required system setup.

27. Terminal diagrams

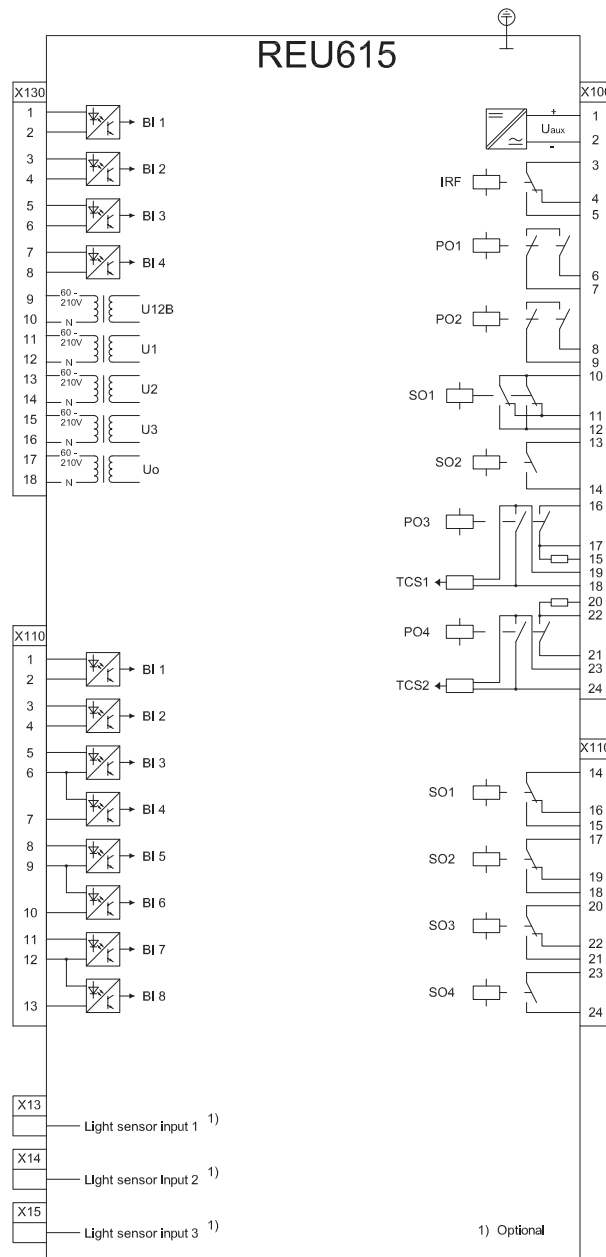

Figure 15. Terminal diagram of standard configuration A

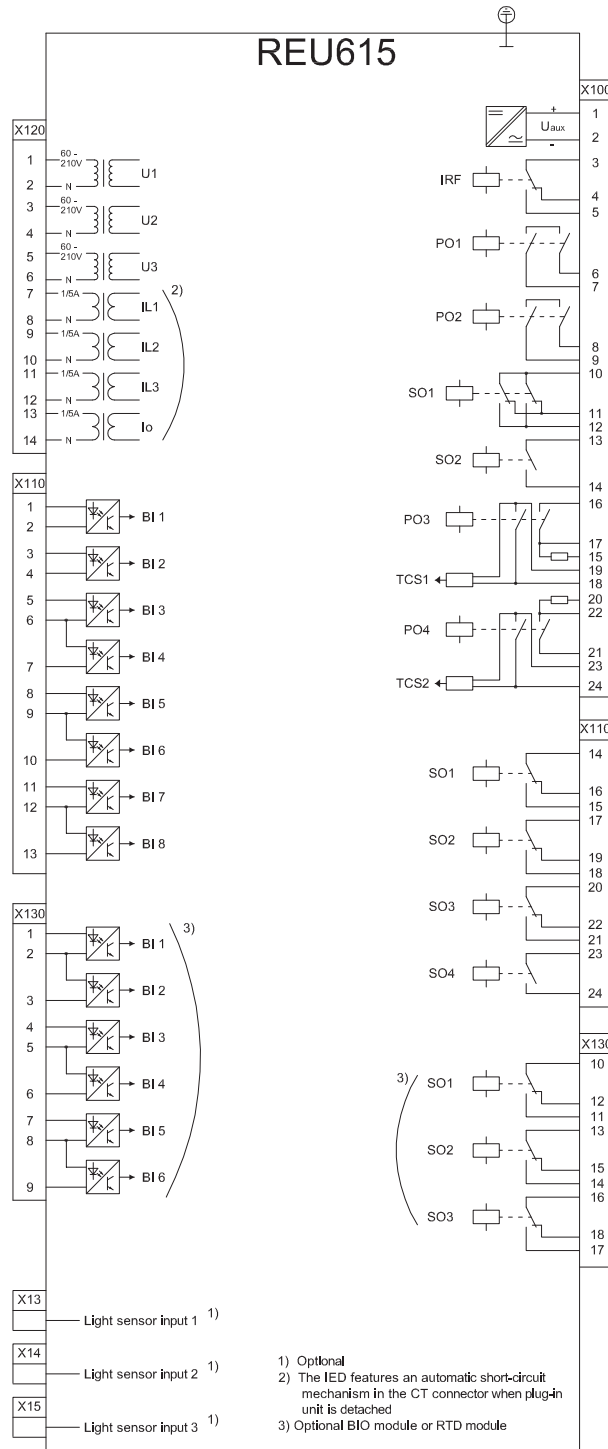

Figure 16. Terminal diagram of standard configuration B

28. Certificates

DNV GL has issued an IEC 61850 Edition 2 Certificate Level A1 for Relion® 615 series. Certificate number: 7410570I-OPE/INC 15-1136.

DNV GL has issued an IEC 61850 Edition 1 Certificate Level A1 for Relion® 615 series. Certificate number: 74105701-OPE/INC 15-1145.

Additional certificates can be found on the [product page](#).

29. References

The www.abb.com/substationautomation portal provides information on the entire range of distribution automation products and services.

The latest relevant information on the REU615 protection and control relay is found on the [product page](#). Scroll down the page to find and download the related documentation.

30. Functions, codes and symbols

Table 78. Functions included in the relay

Function	IEC 61850	IEC 60617	IEC-ANSI
Protection			
Three-phase non-directional overcurrent protection, low stage	PHLPTOC1	3I> (1)	51P-1 (1)
Three-phase non-directional overcurrent protection, high stage	PHHPTOC1	3I>> (1)	51P-2 (1)
Three-phase non-directional overcurrent protection, instantaneous stage	PHIPTOC1	3I>>> (1)	50P/51P (1)
Residual overvoltage protection	ROVPTOV1	U ₀ > (1)	59G (1)
	ROVPTOV2	U ₀ > (2)	59G (2)
	ROVPTOV3	U ₀ > (3)	59G (3)
Three-phase undervoltage protection	PHPTUV1	3U< (1)	27 (1)
	PHPTUV2	3U< (2)	27 (2)
	PHPTUV3	3U< (3)	27 (3)
Three-phase overvoltage protection	PHPTOV1	3U> (1)	59 (1)
	PHPTOV2	3U> (2)	59 (2)
	PHPTOV3	3U> (3)	59 (3)
Positive-sequence undervoltage protection	PSPTUV1	U ₁ < (1)	47U+ (1)
	PSPTUV2	U ₁ < (2)	47U+ (2)
Negative-sequence overvoltage protection	NSPTOV1	U ₂ > (1)	47O- (1)
	NSPTOV2	U ₂ > (2)	47O- (2)
Frequency protection	FRPFRQ1	f>/f<,df/dt (1)	81 (1)
	FRPFRQ2	f>/f<,df/dt (2)	81 (2)
	FRPFRQ3	f>/f<,df/dt (3)	81 (3)
	FRPFRQ4	f>/f<,df/dt (4)	81 (4)
	FRPFRQ5	f>/f<,df/dt (5)	81 (5)
	FRPFRQ6	f>/f<,df/dt (6)	81 (6)
Three-phase thermal overload protection, two time constants	T2PTTR1	3I _{th} >T/G/C (1)	49T/G/C (1)
Master trip	TRPPTRC1	Master Trip (1)	94/86 (1)
	TRPPTRC2	Master Trip (2)	94/86 (2)
Arc protection	ARCSARC1	ARC (1)	50L/50NL (1)
	ARCSARC2	ARC (2)	50L/50NL (2)
	ARCSARC3	ARC (3)	50L/50NL (3)

Table 78. Functions included in the relay, continued

Function	IEC 61850	IEC 60617	IEC-ANSI
Multipurpose protection	MAPGAPC1	MAP (1)	MAP (1)
	MAPGAPC2	MAP (2)	MAP (2)
	MAPGAPC3	MAP (3)	MAP (3)
	MAPGAPC4	MAP (4)	MAP (4)
	MAPGAPC5	MAP (5)	MAP (5)
	MAPGAPC6	MAP (6)	MAP (6)
	MAPGAPC7	MAP (7)	MAP (7)
	MAPGAPC8	MAP (8)	MAP (8)
	MAPGAPC9	MAP (9)	MAP (9)
	MAPGAPC10	MAP (10)	MAP (10)
	MAPGAPC11	MAP (11)	MAP (11)
	MAPGAPC12	MAP (12)	MAP (12)
	MAPGAPC13	MAP (13)	MAP (13)
	MAPGAPC14	MAP (14)	MAP (14)
	MAPGAPC15	MAP (15)	MAP (15)
	MAPGAPC16	MAP (16)	MAP (16)
	MAPGAPC17	MAP (17)	MAP (17)
	MAPGAPC18	MAP (18)	MAP (18)
Load-shedding and restoration	LSHDPFRQ1	UFLS/R (1)	81LSH (1)
	LSHDPFRQ2	UFLS/R (2)	81LSH (2)
	LSHDPFRQ3	UFLS/R (3)	81LSH (3)
	LSHDPFRQ4	UFLS/R (4)	81LSH (4)
	LSHDPFRQ5	UFLS/R (5)	81LSH (5)
Control			
Circuit-breaker control	CBXCBR1	I <-> O CB (1)	I <-> O CB (1)
Disconnecter control	DCXSWI1	I <-> O DCC (1)	I <-> O DCC (1)
	DCXSWI2	I <-> O DCC (2)	I <-> O DCC (2)
Earthing switch control	ESXSWI1	I <-> O ESC (1)	I <-> O ESC (1)
Disconnecter position indication	DCSXSWI1	I <-> O DC (1)	I <-> O DC (1)
	DCSXSWI2	I <-> O DC (2)	I <-> O DC (2)
	DCSXSWI3	I <-> O DC (3)	I <-> O DC (3)
Earthing switch indication	ESSXSWI1	I <-> O ES (1)	I <-> O ES (1)
	ESSXSWI2	I <-> O ES (2)	I <-> O ES (2)
Tap changer position indication	TPOSYLTC1	TPOSM (1)	84M (1)
Tap changer control with voltage regulator	OLATCC1	COLTC (1)	90V (1)
Synchronism and energizing check	SECRSYN1	SYNC (1)	25 (1)
Condition monitoring and supervision			

Table 78. Functions included in the relay, continued

Function	IEC 61850	IEC 60617	IEC-ANSI
Trip circuit supervision	TCSSCBR1	TCS (1)	TCM (1)
	TCSSCBR2	TCS (2)	TCM (2)
Current circuit supervision	CCSPVC1	MCS 3I (1)	MCS 3I (1)
Fuse failure supervision	SEQSPVC1	FUSEF (1)	60 (1)
Runtime counter for machines and devices	MDSOPT1	OPTS (1)	OPTM (1)
Measurement			
Disturbance recorder	RDRE1	DR (1)	DFR (1)
Load profile record	LDPRLRC1	LOADPROF (1)	LOADPROF (1)
Fault record	FLTRFRC1	FAULTREC (1)	FAULTREC (1)
Three-phase current measurement	CMMXU1	3I (1)	3I (1)
Sequence current measurement	CSMSQI1	I1, I2, I0 (1)	I1, I2, I0 (1)
Three-phase voltage measurement	VMMXU1	3U (1)	3V (1)
	VMMXU2	3U (2)	3V (2)
Residual voltage measurement	RESVMMXU1	Uo (1)	Vn (1)
Sequence voltage measurement	VSMSQI1	U1, U2, U0 (1)	V1, V2, V0 (1)
Three-phase power and energy measurement	PEMMXU1	P, E (1)	P, E (1)
RTD/mA measurement	XRGGIO130	X130 (RTD) (1)	X130 (RTD) (1)
Frequency measurement	FMMXU1	f (1)	f (1)
IEC 61850-9-2 LE sampled value sending	SMVSENDER	SMVSENDER	SMVSENDER
IEC 61850-9-2 LE sampled value receiving (voltage sharing)	SMVRVCV	SMVRVCV	SMVRVCV
Other			
Minimum pulse timer (2 pcs)	TPGAPC1	TP (1)	TP (1)
	TPGAPC2	TP (2)	TP (2)
	TPGAPC3	TP (3)	TP (3)
	TPGAPC4	TP (4)	TP (4)
Minimum pulse timer (2 pcs, second resolution)	TPSGAPC1	TPS (1)	TPS (1)
Minimum pulse timer (2 pcs, minute resolution)	TPMGAPC1	TPM (1)	TPM (1)
Pulse timer (8 pcs)	PTGAPC1	PT (1)	PT (1)
	PTGAPC2	PT (2)	PT (2)
Time delay off (8 pcs)	TOFGAPC1	TOF (1)	TOF (1)
	TOFGAPC2	TOF (2)	TOF (2)
	TOFGAPC3	TOF (3)	TOF (3)
	TOFGAPC4	TOF (4)	TOF (4)
Time delay on (8 pcs)	TONGAPC1	TON (1)	TON (1)
	TONGAPC2	TON (2)	TON (2)
	TONGAPC3	TON (3)	TON (3)
	TONGAPC4	TON (4)	TON (4)

Table 78. Functions included in the relay, continued

Function	IEC 61850	IEC 60617	IEC-ANSI
Set-reset (8 pcs)	SRGAPC1	SR (1)	SR (1)
	SRGAPC2	SR (2)	SR (2)
	SRGAPC3	SR (3)	SR (3)
	SRGAPC4	SR (4)	SR (4)
Move (8 pcs)	MVGAPC1	MV (1)	MV (1)
	MVGAPC2	MV (2)	MV (2)
Generic control point (16 pcs)	SPCGAPC1	SPC (1)	SPC (1)
	SPCGAPC2	SPC (2)	SPC (2)
Analog value scaling	SCA4GAPC1	SCA4 (1)	SCA4 (1)
	SCA4GAPC2	SCA4 (2)	SCA4 (2)
	SCA4GAPC3	SCA4 (3)	SCA4 (3)
	SCA4GAPC4	SCA4 (4)	SCA4 (4)
Integer value move	MVI4GAPC1	MVI4 (1)	MVI4 (1)

31. Document revision history

Document revision/date	Product version	History
A/2010-06-11	3.0	First release
B/2010-06-29	3.0	Terminology updated
C/2010-09-07	3.0	Content updated
D/2012-05-11	4.0	Content updated to correspond to the product version
E/2013-02-21	4.0 FP1	Content updated to correspond to the product version
F/2014-01-24	5.0	Content updated to correspond to the product version
G/2015-10-30	5.0 FP1	Content updated to correspond to the product version
H/2016-05-20	5.0 FP1	Content updated
K/2018-12-20	5.0 FP1	Content updated



ABB Distribution Solutions
Distribution Automation

P.O. Box 699
FI-65101 VAASA, Finland
Phone +358 10 22 11

ABB Distribution Automation

Maneja Works
Vadodara-390013, India
Phone +91 265 2604386
Fax +91 265 2638922

www.abb.com/mediumvoltage

www.abb.com/reliion

www.abb.com/substationautomation