

STT850 SmartLine Temperature Transmitter Specification 34-TT-03-14, September 2017



Introduction

Part of the SmartLine® family of products, the SmartLine STT850 is a high-performance temperature transmitter offering high accuracy and stability over a wide range of process and ambient temperatures. The SmartLine family is also fully tested and compliant with Experion® PKS providing the highest level of compatibility assurance and integration capabilities. SmartLine easily meets the most demanding needs for temperature measurement applications.

Best in Class Features:

Industry leading performance

- Digital Accuracy up to +/- 0.10 Deg C for RTD
- Stability up to +/- 0.01% of URL per year for ten years
- 125 mSec update time for single input models
- 250 mSec update time for dual input models

Reliable measurement

- Built in Galvanic Isolation
- Differential/Averaging/Redundant/Split Range measurements
- Dual Compartment Housing
- Sensor Break detection
- Comprehensive on-board diagnostic capabilities
- Full compliance to SIL 2/3 requirements.
- Available with 15 year warranty
- Supports Namur 107 Extended Diagnostics
- Supports Namur 89 Wire break
- Direct entry of Callendar-Van Dusen coefficients R_0 , α , δ and β for calibrated RTD sensors (not available on DE units)



Figure 1– Smartline STT850 Temperature transmitter

Lower Cost of Ownership

- Universal input
- Dual sensor option
- Multiple local display capabilities
- Modular construction
- External zero, span, & configuration capability
- Polarity insensitive loop wiring
- Digital Output Option (only available with HART)

Communications/Output Options:

- 4-20 mA dc
- Honeywell Digitally Enhanced (DE)
- HART® (version 7.0)
- FOUNDATION™ Fieldbus compliant to ITK 6.1.2

All transmitters are available with the above listed communications protocols.

Materials Specifications (see model selection guide for availability/restrictions with various models)

Parameter	Description
Mounting Bracket	Wall or 2" Pipe, Carbon Steel (Zinc-plated) or 316 Stainless Steel
Electronic Housing	Pure Polyester Powder Coated Low Copper (<0.4%)-Aluminum. Meets Type 4X, IP66, & IP67. All stainless steel housing is optional. Cover O Ring Material: Silicone
Sensor/Cable Entry	1/2 NPT electrical connection or M20x1.5
Mounting	Can be mounted in virtually any position using the standard mounting bracket. Bracket is designed to mount on 2-inch (50 mm) vertical or horizontal pipe.
Wiring	Accepts up to 16 AWG (1.5 mm diameter).
Dimensions	See Figures 3 through 8
Net Weight Lbs (kg)	Aluminum housing for transmitter with Display – 2.7 lbs (1.22 kg) Aluminum housing for transmitter w/o Display – 2.6 lbs (1.18 kg) Stainless Steel housing for transmitter with Display – 4.9 lbs (2.22 kg) Stainless Steel housing for transmitter w/o Display – 4.8 lbs (2.18 kg)

Communications Protocols & Diagnostics

HART Protocol

Version:

HART 7

Power Supply

Voltage: 11.8 to 42.4Vdc at terminals

Load: Maximum 1400 ohms See figure 2

Minimum Load: 0 ohms. (For handheld communications a minimum load of 250 ohms is required)

IEC 61508 Safety Certified SIL 2 and SIL 3

Honeywell Digitally Enhanced (DE)

DE is a Honeywell proprietary protocol which provides digital communications between Honeywell DE enabled field devices and Hosts.

Power Supply

Voltage: 13.8 to 42.4Vdc at terminals

Load: Maximum 1300 ohms See figure 2

Foundation Fieldbus (FF)

Power Supply Requirements

Voltage: 9.0 to 32.0 Vdc at terminals

Steady State Current: 17.6 mA

Software Download Current: 27.6 mA

Available Blocks

Block Type	Qty	Execution Time
Resource	1P	n/a
Temperature Transducer	1P	n/a
Diagnostic	1P	n/a
Analog Input	1P, 4I	30 ms
PID w/Autotune	1P, 1I	45 ms
Discrete Input	1P, 2I	30 ms
Signal Characterizer	1P	30 ms

LCD Display	1P	n/a
Input Selector	1P	30 ms
Arithmetic	1P, 2I	30 ms
Output Splitter	1P	30 ms

P = Permanent

I = Instantiable

The AI function block allows the user to configure the alarms to HIGH-HIGH, HIGH, LOW, or LOW-LOW with a variety of priority levels and hysteresis settings.

All available function blocks adhere to FOUNDATION Fieldbus standards. PID blocks support ideal & robust PID algorithms with full implementation of Auto-tuning.

Link Active Scheduler

Transmitters can perform as a backup Link Active Scheduler (LAS) and take over when the host is disconnected. Acting as a LAS, the device ensures scheduled data transfers typically used for the regular, cyclic transfer of control loop data between devices on the Fieldbus.

Number of Devices/Segment

Entity IS model: 15 devices/segment

Schedule Entries

45 maximum schedule entries

50 maximum Links

Number of VCR's: 50 max

Compliance Testing: Tested according to ITK 6.1.2

Software Download

Utilizes Class-3 of the Common Software Download procedure as per FF-883 which allows any field devices to receive software upgrades from any host.

Mounting & Dimensional Drawings

Reference Dimensions: $\frac{\text{millimeters}}{\text{inches}}$

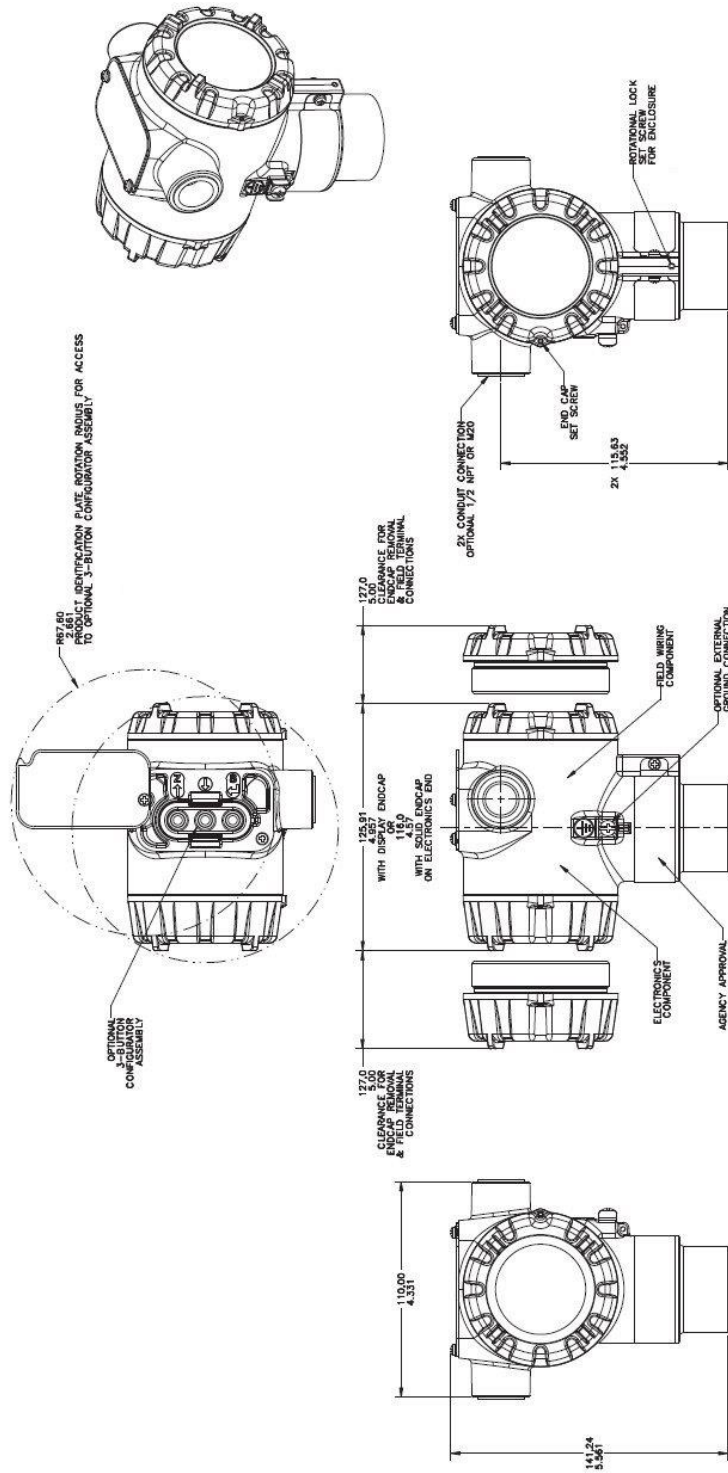

Figure 7 – STT850 with adapter housing - Dimensions

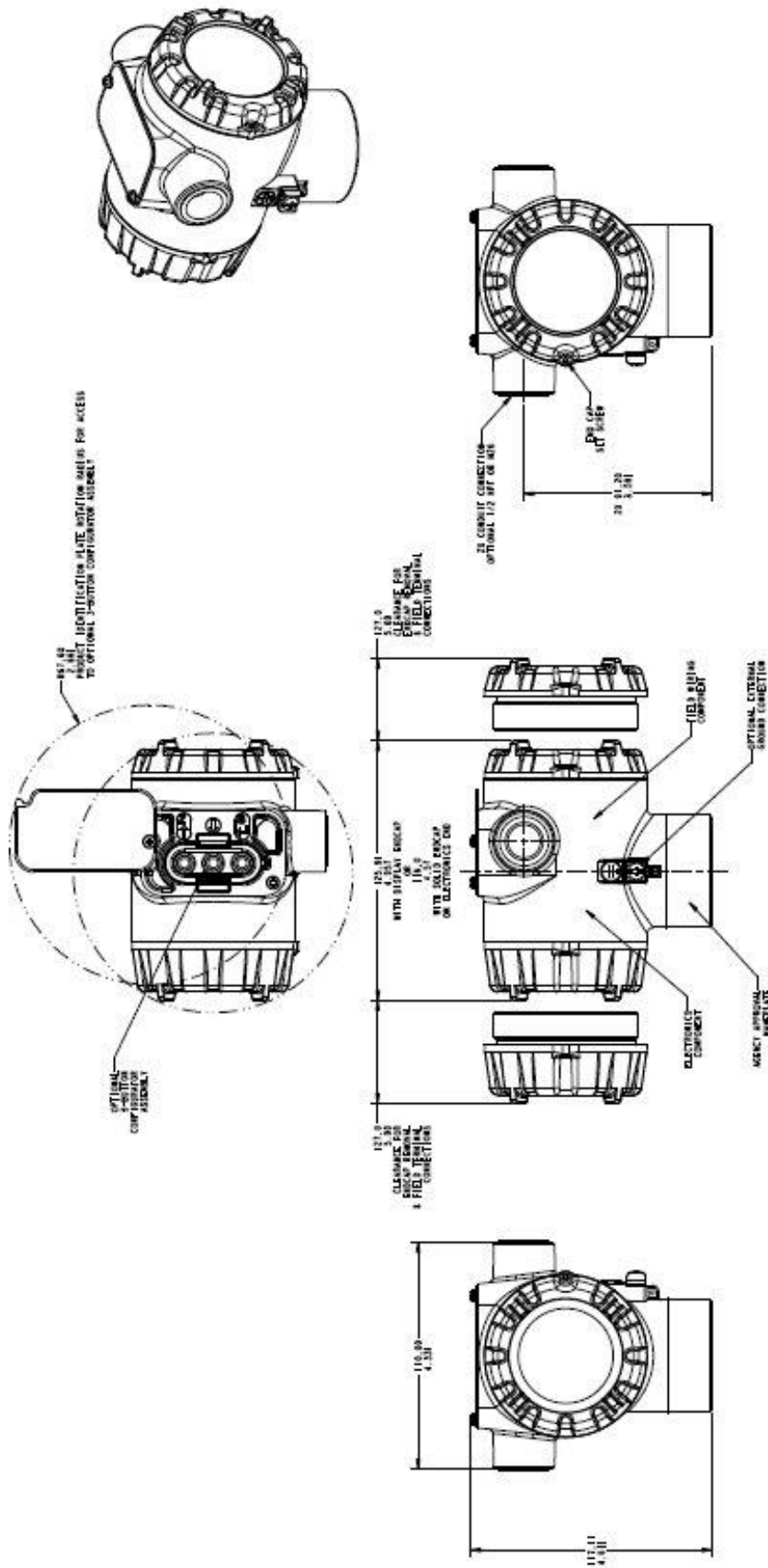

Figure 8 – STT850 no adapter housing dimensions